



# *AFA4000/E*

## *VAV Airflow Controller*

---

Installation and operating manual

Issue 2





# Contents

<b>1. Introduction</b>	<b>5</b>
1.1 Features	5
<b>2. Safety</b>	<b>6</b>
2.1 Safety practices	6
2.2 Precautions	6
2.3 Warnings	6
2.4 Operating conditions	7
2.5 Electrical safety	8
2.6 Electrical protection	9
2.7 EMC compliance	10
<b>3. Overview: Airflow Monitor</b>	<b>11</b>
3.1 Introduction	11
3.2 Display	12
3.3 Alarms and events	14
3.4 Controls and indicators	16
3.5 Operator display panel menu navigation	18
3.6 External connections	20
3.7 Functions	22
3.8 Components	33
<b>4. Overview: Auto Sash Controller</b>	<b>36</b>
4.1 Features	36
4.2 Auto Sash control options	37
4.3 Control system components	41
<b>5. Installation: Airflow Monitor</b>	<b>48</b>
5.1 Location	48
5.2 Installation	50
5.3 Connections	55
5.4 Dimensions	61
5.5 Start up	63

<b>6.</b>	<b>Installation: Auto Sash Controller .....</b>	<b>65</b>
6.1	Auto Sash Control Unit.....	65
6.2	Auto Sash motor drive unit.....	68
6.3	Sash light curtain.....	74
6.4	Installing and aligning the Under Sash sensor .....	82
6.5	Tilt switch .....	84
6.6	Sash Low switch .....	85
6.7	Sash position sensor .....	87
6.8	Personnel sensor.....	89
6.9	Auto Sash System Control Box - general wiring diagram.....	96
6.10	Start up.....	97
<b>7.</b>	<b>Calibration .....</b>	<b>98</b>
7.1	AFA4000/E and AFA4000/E/AS Airflow Monitors .....	98
7.2	Auto Sash Controller 1, 2 or 3 position. ....	101
7.3	Sash lock function .....	104
7.4	Over Current Monitor.....	105
7.5	Auto Stop.....	106
7.6	Auto Sash Controller – stand-alone .....	107
<b>8.</b>	<b>Configuration .....</b>	<b>117</b>
8.1	AFA4000/E configuration menus .....	118
8.2	Control settings.....	125
8.3	Control Setup Guide.....	132
8.4	AFA4000/E/AS configuration menus .....	133
8.5	Dual Output – Econ Output 2.....	145
8.6	Auto Sash Controller system menus.....	157
<b>9.</b>	<b>Auxiliary features and connections .....</b>	<b>166</b>
9.1	Dual set point (occupancy) operation.....	166
9.2	Optional input function - temperature sensor .....	168
9.3	Optional input function – close sash alarm .....	171
9.4	Fail safe damper operation.....	175
<b>10.</b>	<b>RS485 communications output .....</b>	<b>177</b>

10.1	Overview and connections.....	177
10.2	Configuration settings.....	178
10.3	Config Manager.....	181
<b>11.</b>	<b>Operation: Airflow Monitor .....</b>	<b>183</b>
11.1	Run screen.....	183
<b>12.</b>	<b>Operation: Auto Sash Controller .....</b>	<b>184</b>
12.1	Control philosophy.....	184
12.2	Modes of operation .....	184
12.3	Operation and alarm indication.....	187
<b>13.</b>	<b>Troubleshooting .....</b>	<b>189</b>
13.1	Fault finding .....	189
13.2	Diagnostics menu.....	192
13.3	Auto sash alarm indications.....	194
<b>14.</b>	<b>Cleaning and maintenance.....</b>	<b>196</b>
14.1	Cleaning.....	196
14.2	Contamination .....	197
14.3	Maintenance .....	197
<b>15.</b>	<b>Technical specifications .....</b>	<b>198</b>
15.1	AFA4000/E Airflow Monitor.....	198
15.2	Auto Sash Controller .....	199
<b>16.</b>	<b>Warranty.....</b>	<b>205</b>
<b>17.</b>	<b>Index.....</b>	<b>206</b>



# 1. Introduction

The TEL AFA4000 is a system for controlling and monitoring airflow in industrial and educational fume cupboards and biological safety cabinets for user safety. The AFA4000 airflow monitor and controller is available with optional Auto Sash integration. Using the Auto Sash with the AFA4000 controller means you will no longer need a separate Auto Sash keypad.

The AFA4000 user interface is full colour, intuitive and is easy to navigate. It features a simple two-step calibration process with on-screen prompts to guide end users. The unrivalled reliability of the AFA4000 means that once calibrated, you will not need to re-calibrate in the future. The AFA4000 has in-built communications as standard and it can be used with either Modbus or BACnet protocol.

Featuring an innovative hot wire sensor, the AFA4000 has no inherent drift meaning that the sensor will provide stable readings over many years of operation ensuring reliability and safety.

The AFA4000 has full alarm diagnostics and test functionality, a sixty-minute timeline of environmental conditions and field-upgradable software, with password protected menus and diagnostic menus to aid installation and commissioning.

This manual covers the AFA4000/E and AFA4000/E/AS VAV airflow controllers.

## 1.1 Features

- Full colour 3.5" LCD Display for continuous velocity reading in m/sec
- Auto Sash integration
- BACnet and Modbus on board
- Velocity bar graph or fault timeline over the last 60 minutes
- Visual & audible alarms
- Three digital inputs and three digital outputs
- Diagnostics Menu
- Bespoke overlay designs, with a choice of two, coloured cases
- Bespoke software options tailored to customer requirements
- Touch sensitive buttons

## 2. Safety

### 2.1 Safety practices

This guide is a supplement to the safety codes of the user's country. Not every safety procedure that should be followed is covered by this guide. Maintaining a safe laboratory environment is the responsibility of the user.

Review product documentation prior to use and follow instructions carefully.

If the Airflow Monitor or Auto Sash Controller are not used or operated in accordance with this manual, the protection provided by the devices may be impaired.

### 2.2 Precautions

- Ensure the equipment voltage corresponds to the voltage available at the installation position.
- Do not remove equipment panels without shutting down the equipment and disconnecting the power supply.

### 2.3 Warnings

#### 2.3.1 Warning notices

WARNINGS must be followed in order to avoid personal injury.

#### 2.3.2 Warning labels

WARNINGS appear as follows:



Switch off the mains voltage and remove the mains cord before maintenance.

Always follow the instructions given by warning labels on the equipment. For further information refer to this guide and other documentation provided.

## 2.4 *Operating conditions*

### 2.4.1 *General operation*

The Airflow Monitor and associated equipment have been designed and tested in accordance with the International Electrotechnical Commissions (IEC) safety requirements. The Airflow Monitor conforms to IEC61010-1 (Safety Requirements for electrical equipment for measurement, control and laboratory use) as it applies to IEC Class 1 (earthed) appliances, and therefore meets the requirements of EC directive 2014/30/EU.

Adjustment, maintenance or repair of the equipment whilst covers are open or the equipment is in operation is only to be done by skilled persons who are aware of the potential hazards.

Make unsafe equipment inoperative.

Examples of unsafe equipment:

- Appears damaged
- Fails to perform correctly
- Has undergone transport stresses
- Has been stored incorrectly

### 2.4.2 *Environmental conditions*

Ensure the equipment is used under the following conditions:

- Indoors
- Temperature, 5°C to 40°C
- Relative humidity below 80% for temperatures up to 31°C, decreasing linearly to 50% at 40°C
- Electrical supply fluctuations not to exceed +10% of nominal voltage



The protection provided by the equipment may be impaired if the environmental conditions do not lie within these parameters.

## 2.5 *Electrical safety*



Lethal voltages are present at certain points within the equipment.

When the equipment is connected to mains power, removing the equipment's covers is likely to expose live parts.

Even when the power switch is off, high voltage can still be present. Capacitors within the equipment may still be charged even if the equipment has been disconnected from all live voltage sources.

Connect the Airflow Monitor and associated equipment correctly to a suitable electrical supply. The supply must have a correctly installed protective conductor (earth or ground), which must be installed and checked by a qualified electrician before initial power up.



Any interruption of the protective conductor inside or outside the Airflow Monitor and Auto-Sash Controller Systems, or disconnection of the protective conductor terminal is likely to make the equipment dangerous.

Never interrupt the protective conductor.



If the mains power cord needs to be replaced, ensure that the replacement cord is appropriately rated and approved for the intended use.



To prevent potential personal injury and damage to the equipment, switch OFF all components in the system and disconnect them from the mains power supply before altering or making any new electrical connections.

When working with the Airflow Monitor System and/or the Auto Sash Controller System:

- Only connect the equipment to a correctly installed mains power outlet that has a protective conductor connection.
- Do not operate equipment with any covers or internal parts removed.
- Disconnect the equipment from live voltage sources before adjustments, replacements, maintenance or repairs are carried out. If the equipment must be operated during adjustment, maintenance or repair, only a supplier's Service Engineer is to carry out the procedure.



- Ensure equipment that is not electrically safe is made inoperative. Secure the equipment against unauthorised or unintentional operation. Examples of electrically unsafe equipment conditions are as follows:
  - Appears damaged
  - Has undergone transport stresses
  - Has been stored incorrectly

## 2.6 *Electrical protection*

Observe the following electrical protection precautions:

<b>Insulation:</b>	Class I rating for external circuits. Only connect equipment that meets the requirements of IEC 61010-1, IEC 60950 or equivalent standards.
<b>Installation category:</b>	The equipment can withstand transient over-voltages typically present on the mains supply. The normal level of transient over-voltages is impulse withstand (overvoltage) Category II of IEC 60364-4-443.
<b>Pollution degree 2:</b>	Normally only non-conductive pollution occurs. Occasionally, however, temporary conductivity caused by condensation must be expected.
<b>External circuits:</b>	External circuits which are connected to the Auto Sash controller, except mains connection, shall be insulated by double or reinforced insulation from the mains.

## **2.7** *EMC compliance*

### **2.7.1** *EC Directive*

The Airflow Monitor and Auto Sash Controller Systems are designed and tested to meet the requirements of the EC directive 2014/30/EU and complies with the EMC standard EN61326 (EMC standard for electrical equipment for measurement, control and laboratory use) and EN55011 (ISM) Class A (RF emissions).

### **2.7.2** *FCC Rules and Regulations*

The Airflow Monitor System and Auto Sash Controller Systems are classified as digital devices used exclusively as industrial, commercial or medical test equipment. They are exempt from the technical standards specified in Part 15 of the FCC Rules and Regulations based on Section 15.103 (c).

## 3. Overview: Airflow Monitor

### 3.1 Introduction

#### 3.1.1 AFA4000/E

The AFA4000/E VAV Controller can be configured in the field to suit all applications, with password-protected menus and diagnostic menus to aid installation and commissioning.

#### 3.1.2 AFA4000/E/AS

The AFA4000/E/AS VAV Controller is integrated with the Auto Sash Controller. To set up the Airflow controller, set the Auto Sash controller to Disabled, Disconnected or Not Configured to ensure that the sash is under manual control whilst the AFA4000/E/AS airflow monitor is commissioned. The AFA4000/E/AS auto-detects that the Auto Sash Controller is connected and the Auto Sash menus and Operation status will not be displayed if the Auto sash is not connected.

*Note* The Auto Sash can be used to provide a sash position signal to the AFA4000/E/AS when a volumetric output is required from the AFA4000/E/AS. This should be set up once both the AFA4000/E/AS and Auto Sash Controller have been set up and calibrated.

## 3.2 Display

### 3.2.1 Operator display panel



A	Airflow bargraph or timeline display and control status, with ECON operation status where applicable.
B	Airflow velocity display with LED halo (red/amber/green) and optional temperature display
C	Status window, airflow alarm status Auto Sash status
D	Airflow monitor pushbutton icons
E	Airflow monitor pushbuttons
F	Menu pushbuttons and alarm mute Auto Sash Up/Down/Cancel buttons

Figure 1: Operator display panel

*Note: Access to the Calibration and Configuration menus is password protected and is factory set.*

*To access and or change the password contact the supplier for the engineer's password and enter the passwords in the Main Menu, or alternatively use a laptop connected to the Com port and use the Upload/Download software provided.*

### 3.2.2 Display features

The airflow monitor displays the following features:

- The digital display is a backlit, full colour high resolution graphic unit with a visual display area of approximately 70 x 52 mm. The display operates through the software allowing the generation of figures, words and icons. You can choose either blue or black for the background colour of the display.
- Using the alarm keypad, you can configure the display to show the fume cupboard velocity in **m/sec** or **fpm**. Alternatively, you can configure the display to show **AIR FAIL / AIR SAFE** continuously.

The colour of the velocity on the display screen changes when in an alarm condition, to the following:

- Air Safe Green
- Low/ High Air Alarm Red
- Warning Air Alarm Amber

An **'event time line'** segmented into 60 x 1 minute segments scroll across the display (when enabled). The event time line is displayed as a graphical scale ranging over 0-1.00 m/sec that progresses across the screen, representing the airflow value at each segment.

The segment colour changes, as follows, if the value is in the range of an airflow alarm:

- Air Safe White
- Low/ High Air Alarm Red
- Warning Air Alarm Amber

The alternative to the event time line is a dynamic **'bar graph'** representing the airflow velocity.

The output status is permanently displayed under the bar graph or event time line as either **Manual** or **Automatic**. If the controller is configured to dual set-point mode, the status is displayed as **Manual, High Set Point** or **Low Set Point**.

The display shows an up and down arrow icon, , in the bottom right hand corner of the screen when an input function is set to **Hi / Lo** (2 speed operation). The up arrow indicates High speed and the down arrow indicates Low speed.

- The display shows a **Horn** icon (with a line across it) when the audible alarm is muted.
- The display backlight dims to save energy when the following functions are in use:
  - **Fan Off** activated - display backlight dims until **Fan On** is selected. Backlight brightens to normal level when you access the Set Up or Diagnostics menus.
  - **Setback** activated - display backlight dims until the Setback is deactivated. Backlight brightens to normal level when you access the Set Up or Diagnostics menus.
  - **Min Pushbutton** activated – display backlight dims until Pushbutton III is set to **Run** or **Max**. Backlight brightens to normal level when you access the Set Up or Diagnostics menus.
  - **Auto Dim Screen** velocity is exceeded - display backlight dims if the airflow is above the set value. Backlight brightens to normal level when you access the Set Up or Diagnostics menus.

### 3.3 Alarms and events

Message	Displayed when
<b>Sash high</b>	The Sash alarm is activated, and the sash is raised above the maximum safe working opening. <b>Sash high</b> alternates on/off with the velocity reading.
<b>External alarm</b>	The external alarm input is activated (when enabled). <b>External alarm</b> alternates on/off with the velocity reading.
<b>Air safe</b>	The airflow is at a safe velocity. <b>Air Safe</b> alternates on/off with the velocity reading.
<b>Air fail</b>	The airflow is less than the low air alarm point. <b>Air Fail</b> alternates on/off with the velocity reading.
<b>High air (alarm)</b>	The airflow is more than the high air alarm point. <b>High air</b> alternates on/off with the velocity reading.
<b>High Air</b>	The airflow is more than the high air cut off value. <b>High air</b> is displayed without the velocity reading.
<b>Setback</b>	The night setback function is activated. <b>Setback</b> alternates on/off with the velocity reading. The display backlight dims.
<b>Standby</b>	Pushbutton 3 Min function is activated. <b>Standby</b> alternates on/off with the velocity reading. The display backlight dims.
<b>Alarm disabled</b>	The alarm disable function is activated. <b>Alarm disable</b> alternates on/off with the velocity reading.
<b>Close sash</b>	The sash is raised and the operator is not present (when activated). <b>Close sash</b> alternates on/off with the velocity reading.
<b>Emergency</b>	The emergency input is activated or if the <b>MAX</b> or <b>Purge</b> pushbuttons are pressed. <b>Emergency</b> alternates on/off with the velocity reading.
<b>Fire Alarm</b>	The Fire alarm input is activated. <b>Fire alarm</b> alternates on/off with the velocity reading.
<b>Filter Exp</b>	The Hours Counter is enabled and the set hours limit is exceeded. <b>Filter Exp</b> alternates on/off with the velocity reading. A revolving clock icon displays when the fan is on and the counter is active.

Message	Displayed when
<b>Off</b>	Pushbutton I is set to Fan On/Off, hide airflow is enabled when the Fan is switched off. The display backlight dims. All other alarm functions are inhibited in hide airflow fan off condition.
<b>Start Up</b>	Pushbutton I is set to Fan On/Off, the start-up timer is enabled from 0 - 600 seconds when the Fan is switched on. The remaining start up time is displayed. All other alarm functions are inhibited during the start-up period.
<b>Automatic</b>	Econ output is set to Automatic control. It displays at the top of the screen.
<b>Manual</b>	Econ output is set to Manual output. It displays at the top of the screen.
<b>High Set Point</b>	High Set Point (occupied) mode if Dual Set Operation Point is enabled. It displays at the top of the screen.
<b>Low Set Point</b>	Low Set Point (unoccupied) mode if Dual Set Operation Point is enabled. It displays at the top of the screen.
<b>Mute</b>	The audible alarm is muted.
<b>Up / down arrow</b>	The <b>Hi/Lo</b> 2 Speed operation is enabled.
<b>Mains fail</b>	The power fails to connect to the monitor, when activated. <i>Note: This is an optional extra feature that requires an additional battery unit.</i>
<b>Low temperature</b>	The cupboard temperature drops below the low temperature alarm point, when activated. The display alternates on/off with the velocity reading. <i>Note: This is an optional extra feature that requires an additional temperature sensor.</i>
<b>High temperature</b>	The fume cupboard temperature rises above the high temperature alarm point, when activated. The display alternates on/off with the velocity reading. <i>Note: This is an optional extra feature that requires an additional temperature sensor.</i>

## 3.4 Controls and indicators

### 3.4.1 LED Halo indicator

The alarm unit has a LED Halo indicator that changes colour:

- Red Alarm
- Amber Caution
- Green Safe

The Red Alarm LED Halo is illuminated when pushbutton I is set to *Fan On/Off* and is switched off.

### 3.4.2 Audible alarm sounder

The AFA4000/E has an audible sounder with local or remote mute facilities. You can permanently disable the alarm in the *Cal Config Menu*.

The audible alarm is muted when *Fan Off* is selected on pushbutton I or when the Setback or Alarm Disable functions are activated.

When the audible alarm is muted/ disabled, the mute icon displays at the bottom left side of the screen.

When an input is set to the mute function the keypad **Mute** button is disabled and you can only mute the alarm by using the selected mute input.

### 3.4.3 Pushbuttons

The AFA4000/E has 3 menu configurable pushbuttons. Each pushbutton can be configured to a different function. The pushbutton icon and status is shown on the display above the pushbutton.

#### Pushbutton I:

- |             |  |
|-------------|--|
| Fan On/Off  | Displayed when the pushbutton is set to <i>FAN</i> operation.              |
| Setback O/R | Displayed when the pushbutton is set to <i>Setback Override</i> operation. |



## Pushbutton II:

Lights On/Off	Displayed when the pushbutton is set to <i>Lights</i> operation.
UV Lights On/Off	Displayed when the pushbutton is set to <i>UV Lights</i> operation.
Services On/Off	Displayed when the pushbutton is set to <i>Australian Standards</i> operation.
Pump On/Off	Displayed when the pushbutton is set to <i>Pump</i> operation.
Setback O/R	Displayed when the pushbutton is set to <i>Night Setback Override</i> operation.

## Pushbutton III:

Scrubber On/Off	Displayed when the pushbutton is set to <i>Scrubber</i> operation.
Lights On/Off	Displayed when the pushbutton is set to <i>Lights</i> operation.
Purge On/Off	Displayed when the pushbutton is set to <i>Purge VAV</i> operation.
MIN	Displayed with the pushbutton is set to <i>Min/Run/Max VAV</i> operation
RUN	Displayed with the pushbutton is set to <i>Min/Run/Max VAV</i> operation
MAX	Displayed with the pushbutton is set to <i>Min/Run/Max VAV</i> operation

## Mute

The alarm has a multifunctional **Mute** button,  .  
Press **Mute** once, when the alarm is sounding to mute the alarm.  
Press **Mute** for 5 seconds to access the calibration and configuration menus.

## ↑ / ↓

Use the ↑ and ↓ buttons to scroll through the calibration and configuration menus or to select options and values.

## 3.5 Operator display panel menu navigation

To scroll through menu items, press the ↑ and ↓ arrows, then press **Mute** to select an option.

### 3.5.1 Main menu

To display the *Main Menu*, from the *Run Screen*, press and hold the **Mute** button for 5 seconds until the *Main Menu* is displayed.

Menu item	Option	Instructions
Run	<b>Run screen</b>	See <b>Operation</b> section
Set up Monitor	<b>Monitor setup menu</b>	See <b>Monitor set up</b> menu section
Set up Auto Sash <i>Note: This option is only available if the Auto Sash is connected.</i>	<b>Auto Sash Configuration menu</b>	See <b>Auto Sash Configuration menu</b> section

### 3.5.2 Monitor set up menu

Menu item	Option	Instructions
Configure *	<b>Monitor config menu</b>	See section 8.
Calibration *	<b>Calibration</b>	See section 7.
Brightness	<b>Screen Brightness</b>	Adjust Brightness level then press the <b>Mute</b> button.
Passwords *	<b>Monitor passwords menu</b>	Select the password to set: <ul style="list-style-type: none"> <li>• Admin</li> <li>• Calibration</li> <li>• Configure</li> </ul> Enter and re-enter the new password, then press the <b>Mute</b> button. Select <b>Done</b> to return to the Main menu.



Menu item	Option	Instructions
Done	Return to <b>Main menu</b>	

*Note: Menu items marked \* are password protected. To enter the password, use ↑/↓ to change each digit of the password, then press **Mute**.*

### 3.5.3 Auto Sash Configuration menu

*Note: This option is only available if the Auto Sash is connected.*

Menu item	Option	Instructions
TEL Sash Closer	Shows the firmware (F/W) and Hardware (H/W) versions	Read-only information
Setup Menu *	<b>Auto Sash setup menu</b>	See section 8.4.1.
Engineering Menu *		See section 8.4.2.

#### **Auto Sash engineering menu**

Exit	Return to <b>Main menu</b>	
------	----------------------------	--

*Note: Menu items marked \* are password protected. To enter the password, use ↑/↓ to change each digit of the password, then press **Mute**.*

## 3.6 External connections

### 3.6.1 Inputs

The AFA4000/E has the following inputs:

#### 3.6.1.1 Input 1, Input 2, Input 3

These are volt-free inputs configurable for:

- Normally closed relays
- Normally open relays or
- Analogue 0 - 5 Vdc input

The inputs can be configured as:

<b>Digital input functions (closed or open volt free contact):</b>	Fire Alarm	Sash high
	Mute	Emergency
	Fan stop	External alarm
	Personnel sensor	Night set-back
	Mains fail	Alarm disable
	Sash warning	None
<b>Analogue input functions:</b>	High / Low	
	Duct pressure	Sash position
	Volume pressure	Temperature
	Damper feedback	

*Note: Default values are:*

*Input 1: Night setback*

*Input 2: None*

*Input 3: Sash high*

### 3.6.2 Outputs

The AFA4000/E has the following outputs:

#### 3.6.2.1 Relay outputs 1, 2, 3

These are volt-free outputs configurable for:

- Normally closed relays or
- Normally open relays

*Note: Changeover relays are available with the Econ power supply relay interface unit. The relay interface has an AUX relay output that can be selected to duplicate the action of R1, R2 or R3 via a DIP switch.*

### 3.6.2.2 *Econ output 1*

0 - 10 Vdc / 2 – 10 Vdc control output, configurable for direct or indirect action.

### 3.6.2.3 *Econ output 2*

0 - 10 Vdc / 2 – 10 Vdc output, configurable as:

- volumetric 0 – 10 Vdc output (when using sash position or volumetric measuring sensors)
- a second control output, configurable for direct or indirect action, or
- a face velocity retransmission output.

### 3.6.3 *Airflow sensor*

An RJ12 connection socket is provided for the face velocity airflow sensor.

### 3.6.4 *Communications*

#### 3.6.4.1 *Comm port*

RS485 enables connection to a laptop or PC for full diagnostics, logging, configuration and for communications to building management or automation systems (BMS/BAS).

For specific information on Modbus RTU options and settings, see section 8.1.1.3.

For specific information on BACnet options and settings, see section 8.1.1.4.

### 3.6.5 *Power supply*

Low voltage DC power supply from the mains power adaptor or from the Econ power supply (damper control type).

### 3.6.6 *Optional inputs*

#### 3.6.6.1 *Temperature sensor*

Bespoke temperature sensor for connecting into inputs 1, 2 or 3 to give temperature display with high or low temperature alarms.

#### 3.6.6.2 *Volume pressure sensor*

An auxiliary pressure cell PCB fits into the Econ power supply relay interface unit and is dedicated to input 2. This is used for measuring volume on an orifice restriction, or bell-mouth venturi type restrictor.

#### 3.6.6.3 *PIR occupancy sensor*

Auxiliary PIR used for close sash alarm based on the fume cupboard occupancy.

### 3.6.6.4 Sash position sensor

Auxiliary sash position sensor used for volumetric output and sash high alarms with dedicated input on the Econ power supply.

### 3.6.6.5 Mains fail battery unit

Auxiliary plug-in battery unit has a mains fail alarm. This requires inverter type control only and is not to be used if the Econ power supply is fitted.

### 3.6.6.6 Auto sash keypad

RJ45 connection for the Auto Sash keypad. Refer to sections 4 and 7.6 for Auto Sash functions.

## 3.7 Functions

### 3.7.1 Airflow functions

The AFA4000/E airflow display can be set up using the pushbutton menus to display airflow in units of m/sec or fpm and can also be set to show plain text *Air Safe* & *Air Fail* only.

The AFA4000/E has 4 programmable airflow alarms:

Alarm	Description
<b>Safe airflow</b>	<ul style="list-style-type: none"> <li>• Airflow reading above warning level (for example, &gt; 0.45 m/sec)</li> <li>• Green Safe LED Halo illuminated</li> <li>• <i>Air Safe</i> displayed in the status window or main window if Show Airflow is set to OFF.</li> </ul>
<b>Warning airflow</b>	<ul style="list-style-type: none"> <li>• Airflow reads between warning level and air fail level (for example, &gt; 0.4 m/sec and &lt; 0.45 m/sec)</li> <li>• Amber Warning LED Halo illuminated.</li> <li>• <i>Air Safe</i> displayed in the status window or main window if Show Airflow is set to OFF.</li> </ul>
<b>Low airflow</b>	<ul style="list-style-type: none"> <li>• Airflow reads below alarm level for longer than the warning to low air delay time</li> <li>• Red Alarm LED Halo illuminated</li> <li>• <i>Air Fail</i> displayed in the status window or main window if Show Airflow is set to OFF.</li> <li>• Audible alarm sounds - can be muted by pressing the <b>Mute</b> pushbutton</li> </ul>

Alarm	Description
	<ul style="list-style-type: none"> <li>Low air relay operates (if configured)</li> </ul> Reset: when airflow rises 0.02 m/sec above Low air level for longer than the low air to warning air delay time, the Low air alarm resets automatically
<b>High airflow</b>	If configured: <ul style="list-style-type: none"> <li>Airflow reading above high level (for example &gt; 1.50 m/sec)</li> <li>Red Alarm LED Halo illuminated</li> <li><i>High Air</i> displayed in the status window or main window if Show Airflow is set to OFF.</li> <li>Audible alarm sounds - can be muted by pressing the <b>Mute</b> pushbutton</li> <li>High air relay operates (when configured)</li> </ul>

### 3.7.2 Audible alarm mute

When the audible alarm is muted via the **Mute** button, an icon () displays.

The audible alarm can be permanently disabled by selecting **Not Enabled** in the *Cal Config menu* (*Setup Monitor > Configure > Cal Config Menu > Audible Alarm*).

### 3.7.3 Pushbutton functions

The AFA4000/E has 3 programmable pushbuttons. The pushbutton icon is displayed on the screen, above the relevant pushbutton. The pushbuttons are identified as Pushbutton I, Pushbutton II and Pushbutton III.

Each Pushbutton has a Power Up Memory function. The Power Up Memory function sets the pushbutton back to its last status, following a power fail cycle. For example, when the Fan is On during a power failure, the AFA4000/E powers up with the Fan pushbutton set to On.

Each pushbutton has a PIN option selectable as PIN required for On, PIN required for Off or PIN required for both On and Off. When a PIN option is enabled, a New PIN parameter appears, allowing you to set a 4-digit PIN number.

When a PIN is enabled and the pushbutton is pressed, a Password screen displays. If the correct PIN is entered the pushbutton action will be completed; if an incorrect PIN is entered the pushbutton action will remain in its present condition.

The AFA4000/E pushbuttons are typically set to:

- Pushbutton I                      Fan On/Off
- Pushbutton II                     Lights On/Off
- Pushbutton III                    VAV control

### 3.7.3.1 Pushbutton I

Function	Description
<b>Fan Off</b>	<ul style="list-style-type: none"> <li>• Pushbutton I set to <i>Fan On / Off</i> and is Off</li> <li>• Pushbutton Fan Stop parameter set to <i>Hide Airflow</i></li> <li>• Screen Backlight dims to low power mode</li> <li>• Red Alarm LED Halo illuminated</li> <li>• All alarm functions and alarm function outputs are inhibited when the fan is off.</li> </ul> <p><i>Note: When the Fan Stop parameter is set to Show Airflow, in the Fan OFF position, the controller displays the current airflow and all input alarm functions remain active.</i></p>
<b>Fan On</b> <b>Start Up</b> (10 Seconds)	<ul style="list-style-type: none"> <li>• Pushbutton I set to <i>Fan On / Off</i> and is On</li> <li>• Extract Fan Relay is On</li> <li>• Pushbutton Fan Start time parameter set to &gt;0 seconds</li> <li>• All alarm functions and outputs are inhibited during the start-up time period</li> </ul> <p>Start-up Timer: the start-up timer is used to allow the fan to run up to full speed before the AFA1000/E alarm functions are active, so that false Low Air alarms are not sent to the BMS.</p> <p><i>Note: When the Fan Start Time is set to zero, and the fan is switched ON, the airflow velocity displays and all alarm functions are active as soon as the pushbutton is pressed.</i></p>
<b>Setback O/R On/Off</b>	<ul style="list-style-type: none"> <li>• Pushbutton I set to <i>Setback Override On / Off</i></li> <li>• Night setback function is overridden</li> </ul>



When Pushbutton I is set to Fan On/Off, the following additional functions appear in the Pushbutton I configuration menu:

Function	Description
<b>Interlock</b>	<ul style="list-style-type: none"> <li>• Not active</li> <li>• Off enable PB2. Pushbutton II is switched and held OFF if pushbutton I is ON.</li> <li>• On enable PB2. Pushbutton II is switched and held OFF if pushbutton I is OFF.</li> <li>• On Run Up enable PB2. Pushbutton II is enabled when Pushbutton I run up timer has elapsed.</li> </ul>
<b>Run Up Timer</b>	<ul style="list-style-type: none"> <li>• Not enabled / enabled. When enabled, select the Run Up Timer relay and set the Run Up Time. When the fan is set to ON, the Run Up Timer activates after the Run Un Time. This function is used when 2 output relays are required for Pushbutton I.</li> </ul>
<b>Run Down Timer</b>	<ul style="list-style-type: none"> <li>• Enabled / not enabled. When enabled, select the Run Down Time. When the fan is set to OFF, the fan remains on for the set time, and a down arrow next to the pushbutton icon appears to indicate that the Run Down Timer is active.</li> </ul>

### 3.7.3.2 Pushbutton II

Function	Description
<b>Lights On / Off</b>	<ul style="list-style-type: none"> <li>• Pushbutton II set to <i>Lights On / Off</i></li> <li>• Lights On / Off Relay operates</li> </ul>
<b>UV Lights On / Off</b>	<ul style="list-style-type: none"> <li>• Pushbutton II set to <i>UV Lights On / Off</i></li> <li>• UV Lights On / Off Relay operates</li> </ul>
<b>Services On / Off</b>	<p>For Australian Standards Operation only. This requires a special software version.</p> <p>The following parameters should be set:</p> <ul style="list-style-type: none"> <li>• Pushbutton I icon set to Fan On/Off, Relay Output 1</li> <li>• Pushbutton I interlock = On Run Up Pb2</li> <li>• Pushbutton I interlock Run Up Timer = set to the required pre-purge time</li> </ul>

Function	Description						
	<ul style="list-style-type: none"> <li>• Pushbutton 1 Run Down Timer = set to the required post-purge time</li> <li>• Pushbutton 2 icon set to Services On/Off, Relay Output 2</li> </ul> <p>Operation:</p> <table border="0"> <tr> <td data-bbox="660 734 979 770">Fan On / Pre-purge period</td> <td data-bbox="1050 734 1394 860"> <ul style="list-style-type: none"> <li>• Services Output disabled</li> <li>• Services icon flashes</li> <li>• Fan runs</li> </ul> </td> </tr> <tr> <td data-bbox="660 878 967 913">Pre-purge period elapsed</td> <td data-bbox="1050 878 1385 1169"> <ul style="list-style-type: none"> <li>• Services icon = Rst. Can be switched on if airflow is safe. Will revert to Rst (Off) if Low Air Alarm activates. Disabled until airflow is safe.</li> </ul> </td> </tr> <tr> <td data-bbox="660 1187 991 1223">Fan Off / Post-purge period</td> <td data-bbox="1050 1187 1401 1352"> <ul style="list-style-type: none"> <li>• Services Output Off</li> <li>• Services icon flashes</li> <li>• Fan runs for post=purge period, then switches off.</li> </ul> </td> </tr> </table>	Fan On / Pre-purge period	<ul style="list-style-type: none"> <li>• Services Output disabled</li> <li>• Services icon flashes</li> <li>• Fan runs</li> </ul>	Pre-purge period elapsed	<ul style="list-style-type: none"> <li>• Services icon = Rst. Can be switched on if airflow is safe. Will revert to Rst (Off) if Low Air Alarm activates. Disabled until airflow is safe.</li> </ul>	Fan Off / Post-purge period	<ul style="list-style-type: none"> <li>• Services Output Off</li> <li>• Services icon flashes</li> <li>• Fan runs for post=purge period, then switches off.</li> </ul>
Fan On / Pre-purge period	<ul style="list-style-type: none"> <li>• Services Output disabled</li> <li>• Services icon flashes</li> <li>• Fan runs</li> </ul>						
Pre-purge period elapsed	<ul style="list-style-type: none"> <li>• Services icon = Rst. Can be switched on if airflow is safe. Will revert to Rst (Off) if Low Air Alarm activates. Disabled until airflow is safe.</li> </ul>						
Fan Off / Post-purge period	<ul style="list-style-type: none"> <li>• Services Output Off</li> <li>• Services icon flashes</li> <li>• Fan runs for post=purge period, then switches off.</li> </ul>						
<b>Pump On / Off</b>	<ul style="list-style-type: none"> <li>• Pushbutton II set to <i>Pump On / Off</i></li> <li>• Pump On / Off Relay operates</li> </ul>						
<b>Setback O/R On/Off</b>	<ul style="list-style-type: none"> <li>• Pushbutton II set to <i>Setback Override On / Off</i></li> <li>• Night setback function is overridden</li> </ul>						

### 3.7.3.3 Pushbutton III

Function	Description
Scrubber On / Off	<ul style="list-style-type: none"> <li>• Pushbutton III set to <i>Scrubber On / Off</i></li> <li>• <i>Scrubber On / Off</i> Relay operates</li> </ul>
Lights On / Off	<ul style="list-style-type: none"> <li>• Pushbutton III set to <i>Lights On / Off</i></li> <li>• Lights On / Off Relay operates</li> </ul>
Purge On / Off	<ul style="list-style-type: none"> <li>• Pushbutton III set to <i>Purge On / Off</i></li> <li>• <i>Emergency</i> toggles on/off with other alarms in the status window</li> <li>• VAV output goes to Max, regardless of sash position</li> <li>• Red Alarm LED Halo illuminated</li> <li>• Audible alarm sounds - can be muted by pressing the <b>Mute</b> pushbutton</li> <li>• Purge On /Off Relay operates (if configured)</li> </ul>
<b>VAV Min/Run/Max or VAV Min/Normal functions:</b>	
<b>Min</b>	<ul style="list-style-type: none"> <li>• Pushbutton III set to <i>VAV Min/Run/Max</i> and is set to Min</li> <li>• <i>Standby</i> toggles on/off with other alarms in the status window</li> <li>• VAV output goes to Min, regardless of sash position</li> <li>• Audible alarm is muted</li> </ul>
<b>Run</b>	<ul style="list-style-type: none"> <li>• Pushbutton III set to <i>VAV Min/Run/Max</i> and is set to Run</li> <li>• <i>Airflow value</i> displays in the status window</li> <li>• VAV operation is active</li> <li>• Airflow alarms are enabled</li> </ul>
<b>Max</b> ( <i>VAV Min/Run/Max only</i> )	<ul style="list-style-type: none"> <li>• Pushbutton III set to <i>VAV Min/Run/Max</i> and is set to Max</li> <li>• <i>Emergency</i> toggles on/off with other alarms in the status window</li> <li>• VAV output goes to Max, regardless of sash position</li> <li>• Audible alarm sounds - can be muted by pressing the <b>Mute</b> pushbutton</li> </ul>

### 3.7.4 *Input functions*

The AFA4000/E has 3 programmable inputs that can be set to:

- Analogue (0 - 5 Vdc)
- Digital open operation or
- Digital closed operation

#### 3.7.4.1 *Analogue input functions*

Function	Description
<b>Temperature</b>	<ul style="list-style-type: none"> <li>• Any Input set to Analogue - Temperature</li> <li>• Temperature is displayed alongside airflow velocity in °C or °F (if <i>Show Temp</i> is enabled)</li> <li>• <i>Low Temp</i> toggles on / off with other alarms in the status window if temperature is less than the Low Temp Alarm point</li> <li>• Red Alarm LED Halo illuminated</li> <li>• Audible alarm sounds - can be muted by pressing the <b>Mute</b> pushbutton</li> <li>• Low Temp relay operates (when configured)</li> <li>• <i>High Temp</i> toggles on / off with other alarms in the status window if temperature is higher than the High Temp Alarm point</li> <li>• Red Alarm LED Halo illuminated</li> <li>• Audible alarm sounds - can be muted by pressing the <b>Mute</b> pushbutton</li> <li>• High Temp relay operates (if configured)</li> <li>• <i>Temp Error</i> toggles on / off with other alarms in the status window if a temperature sensor input is configured but a sensor is not connected to the controller</li> <li>• <i>Offset</i> allows the displayed temperature to be offset by <math>\pm 5^{\circ}\text{C}</math> or <math>\pm 10^{\circ}\text{F}</math></li> </ul>
<b>Sash Position Sensor</b>	<ul style="list-style-type: none"> <li>• Any Input set to Analogue – Sash Position</li> <li>• Used to give calculated volumetric output signal based on sash position and airflow velocity</li> <li>• Can also be used to give Sash High Alarm</li> <li>• <i>Sash High</i> toggles on / off with other alarms in the status window if the sash height is higher than the calibrated position</li> </ul>

Function	Description
	<ul style="list-style-type: none"> <li>• Amber Alarm LED Halo illuminated</li> <li>• Audible alarm sounds - can be muted by pressing the <b>Mute</b> pushbutton</li> <li>• Sash High relay operates (if configured)</li> </ul>
<b>Volume Pressure</b>	<ul style="list-style-type: none"> <li>• Input 2 or 3 set to Analogue – Volume Pressure</li> <li>• Used to give volumetric output based on duct measurement using restrictor device</li> </ul>
<b>Damper Feedback</b>	<ul style="list-style-type: none"> <li>• Input 2 or 3 set to Analogue – Damper Feedback</li> <li>• Used for sash position control (AFA3000) model only</li> </ul>

### 3.7.4.2 *Digital input functions*

Function	Description
<b>Alarm disable</b>	When input configured as Alarm is disabled: <ul style="list-style-type: none"> <li>• <i>Alarm disabled</i> displays in the status window</li> <li>• Red Alarm LED Halo illuminated</li> <li>• Audible alarm muted</li> <li>• Mute Icon shown on display</li> </ul>
<b>Night set-back</b>	When input configured as Night Set-back is activated: <ul style="list-style-type: none"> <li>• <i>Night Set-back</i> displays in the status window</li> <li>• Unit is driven to the VAV MIN operating position</li> <li>• Audible alarm muted</li> <li>• Mute Icon displays</li> <li>• Low Air alarm muted if set to <i>Maintain Low Air</i></li> <li>• Reduce Low Air &amp; Warning alarms active if set to <i>Reduce Low Air</i></li> </ul>
<b>External alarm</b>	When input configured as External alarm is activated: <ul style="list-style-type: none"> <li>• Red Alarm LED Halo illuminated</li> <li>• <i>External Alarm</i> toggles on / off in the status window (when configured)</li> <li>• Audible alarm sounds. Can be muted by pressing the <b>Mute</b> pushbutton</li> <li>• External Alarm relay operates (when configured)</li> </ul>

Function	Description
<b>Emergency</b>	<p>When input configured as Emergency is activated:</p> <ul style="list-style-type: none"> <li>• Red Alarm LED Halo illuminated</li> <li>• <i>Emergency</i> toggles on /off in the status window (when configured)</li> <li>• Audible alarm sounds. Can be muted by pressing the <b>Mute</b> pushbutton</li> <li>• Emergency alarm relay operates (when configured)</li> <li>• Unit is driven to the VAV MAX operating position</li> </ul>
<b>Sash High</b>	<p>When input configured as Sash High is activated:</p> <ul style="list-style-type: none"> <li>• Amber Alarm LED Halo illuminated</li> <li>• <i>Sash High</i> toggles on / off in the status window if sash height &gt; calibrated position</li> <li>• Audible alarm sounds. Can be muted by pressing the <b>Mute</b> pushbutton</li> <li>• Sash High relay operates (when configured)</li> <li>• Alarm re-activates after time delay when repeat time enabled</li> </ul>
<b>High / Low</b>	<p>When input configured as High/Low is activated:</p> <ul style="list-style-type: none"> <li>• Display Icon shows ↑ (High) or ↓ (Low)</li> <li>• High / Low relay operates (when configured)</li> <li>• This function is designed for two-speed fan operation or two-position damper operation switched using a micro switch or proximity switch activated at a given position on the sash.</li> </ul>
<b>Sash Warning</b>	<p>When the input configured as Close Sash is activated:</p> <ul style="list-style-type: none"> <li>• Red Alarm LED Halo illuminated</li> <li>• <i>Close Sash</i> - toggles on/off in the status window</li> <li>• Audible alarm sounds (after pre-set time)</li> <li>• Audible can be muted by pressing the <b>Mute</b> pushbutton. This silences the alarm (when configured)</li> <li>• Audible alarm re-sounds after time delay when repeat time enabled</li> <li>• Reset when the sash is lowered to closed position and the input is de-activated or an operator is present</li> </ul>

Function	Description
<b>Mains Fail</b> <i>(Optional extra feature)</i>	When the input configured as Mains Fail is activated: <ul style="list-style-type: none"> <li>• Red Alarm LED Halo illuminated</li> <li>• <i>Mains Fail</i> displays</li> <li>• Audible alarm sounds</li> <li>• Audible can be muted by pressing the <b>Mute</b> pushbutton. This silences the alarm (when configured)</li> </ul> <i>Note: Not for use with the Relay Interface Unit.</i>
<b>Personnel Sensor</b> <i>(Optional extra feature)</i>	When the input configured as Personnel Sensor is activated: <ul style="list-style-type: none"> <li>• VAV Dual Set Point is active:               <ul style="list-style-type: none"> <li>Occupied = High Set Point;</li> <li>Unoccupied = Low Set Point</li> </ul> </li> </ul> <i>Note: When the Low Set Point is active, the Reduced Low Air and Warning Air Alarms are active.</i>
<b>Fan Stop</b>	When the input configured as Fan Stop is activated: <ul style="list-style-type: none"> <li>• <i>Off</i> displays</li> <li>• Red LED Halo illuminated</li> <li>• Audible alarm muted</li> </ul> When the input configured as Fan Stop is de-activated: <ul style="list-style-type: none"> <li>• <i>Start Up Timer</i> displays</li> <li>• Audible alarm and relays inhibited until Start up time has elapsed</li> </ul> <i>Note: Used if the AFA4000 is a Slave unit with a common fan. Remote master On/Off signal is used</i>
<b>Mute</b>	When the input configured as Mute is activated: <ul style="list-style-type: none"> <li>• Audible alarm muted</li> <li>• Mute Icon shown on display</li> </ul> <i>Note: The Mute function disables the <b>Mute</b> pushbutton so that any audible alarm can only be muted using the input, for example remote key switch</i>



---

Function	Description
<b>Fire Alarm</b>	When the input configured as Fire Alarm is activated: <ul style="list-style-type: none"><li data-bbox="603 600 1023 629">• Red Alarm LED Halo illuminated</li><li data-bbox="603 645 863 674">• <i>Fire Alarm</i> displays</li><li data-bbox="603 689 895 719">• Audible alarm sounds</li><li data-bbox="603 734 1374 808">• Audible can be muted by pressing the <b>Mute</b> pushbutton. This silences the alarm (when configured)</li><li data-bbox="603 824 1326 853">• Unit is driven to the Fully Closed or Off operating position</li></ul>

---





### 3.8.2 Damper control components

- 1 – AFA4000/E monitor
- 1 – Airflow Sensor c/w 2 metre RJ45 sensor cable
- 1 – Econ Power Supply Unit c/w 2 metre ribbon cable
- 1 – Electrical Damper Actuator c/w 3 metre flying lead

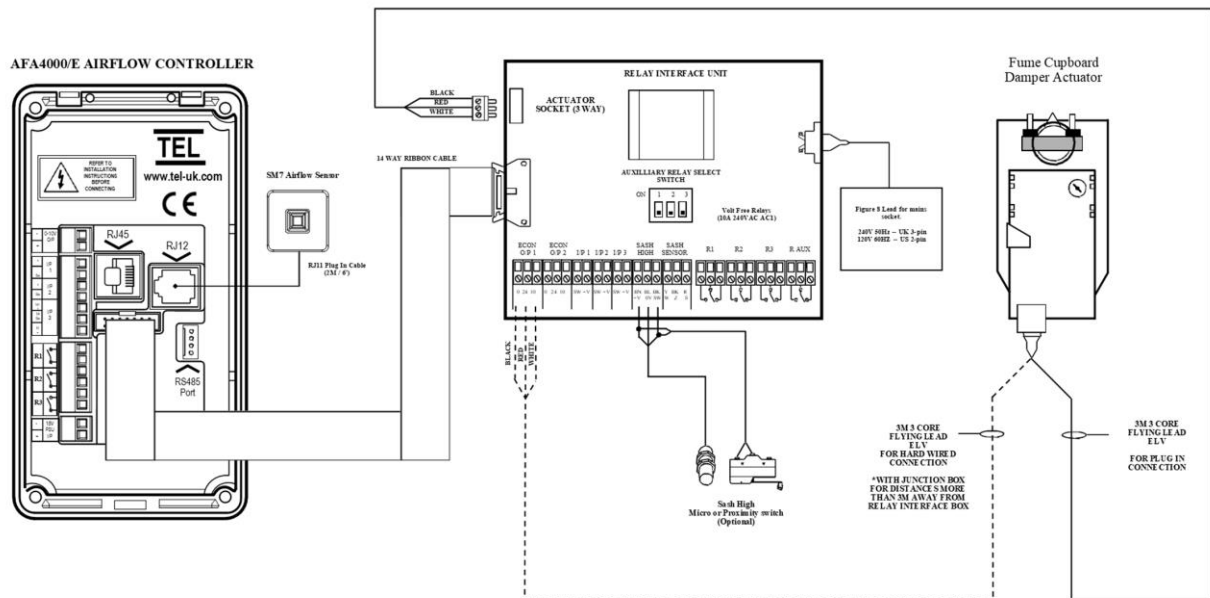

Figure 3: AFA4000/E damper control components

### 3.8.3 *Auxiliary components*

The following auxiliary components are available for the AFA4000/E airflow monitor:

<b>Component</b>	<b>Function</b>
<b>Sash High Proximity Switch</b>	Used for Sash High Alarm
<b>Sash High Micro Switch</b>	Used for Sash High Alarm
<b>Sash Position Sensor (sprung potentiometer)</b>	Used for Volumetric Output and Sash High Alarm
<b>Personnel Sensor</b>	Passive Infra-Red sensor. Used for Dual Set Point Control and Close Sash Alarm
<b>Mains Fail Battery Unit</b>	Used for Mains Fail Alarm (inverter control type only)
<b>Volume Pressure Sensor</b>	Used for Volumetric Output using a separate venturi device or orifice plate type restrictor
<b>Temperature Sensor</b>	Used for Temperature display and alarms

## 4. Overview: Auto Sash Controller

The Auto Sash Controller automates the opening and closing of the fume hood sash. Automation of the sash movement provides an increased level of safety to the controlled environment. A sash cannot be accidentally left open and can respond to safety critical inputs from external sources, such as fire alarms and ventilation system failures.

The Auto Sash Controller facilitates cost savings. When linked to ventilation controls, the automatic closing of an unattended fume hood allows extractor fan speeds and electricity consumption to be reduced.

### 4.1 Features

The Auto Sash Controller has the following features:

• <b>Auto-Close</b>	The sash automatically closes when the fume hood is unattended.
• <b>Auto-Open</b>	The sash automatically opens when the user returns.
• <b>Tiptronic Open/Close</b>	Touch sensitive sash movement (menu selectable)
• <b>Sash Lock</b>	The sash is programmed to lock at a designated position.
• <b>Manual Sash Open/Close</b>	To open/close the sash manually.
• <b>Keypad Pushbutton Open/Close</b>	To open/close the sash using the Keypad Pushbuttons.
• <b>Footswitch</b>	To open / close the sash using an optional footswitch.
• <b>Tilt Switch</b>	To disable the Auto Sash Control Unit using a tilt switch.
• <b>Building Management System (BMS) Inputs</b>	The sash automatically opens or closes when a signal is received from the BMS.
• <b>Building Management System (BMS) Outputs</b>	The Auto Sash Controller sends signals to the BMS regarding the current status of the fume hood.
• <b>Auto Stop</b>	When manually operated the sash stops at the mid position
• <b>Current Monitoring</b>	The sash is stopped if the load increases above a set level

## 4.2 *Auto Sash control options*

To open / close the fume hood sash the Auto Sash Controller is fitted with:

- A Tiptronic open/close control via the Sash Position Sensor.
- A Sash Low micro-switch
- A Sash Low proximity switch

### 4.2.1 *Auto Sash Controller with Tiptronic open / close control*

Tiptronic Open / Close control is the default control setup. It functions via a Sash Position Sensor (sprung potentiometer) with a draw wire (1.2m long) attached to either the sash or the counterweight. The Auto Sash Controller can then be calibrated to give three methods of operation:

---

#### **Method A - Close only**

- The bottom position is calibrated.
- The sash automatically drives to the bottom position, when the user is not present.
- Press the ↓ pushbutton to drive the sash to the bottom position, when the user is present.
- The ↑ pushbutton is disabled.

---

#### **Method B - 2 Positions**

- The bottom and mid-positions are calibrated.
  - The sash automatically drives to the bottom position, when the user is not present.
  - Press the ↓ pushbutton to drive the sash to the bottom position, when the user is present.
  - Press the ↑ pushbutton to drive the sash to the mid-position, when the user is present.
  - When the Tiptronic feature is enabled, manually tip the sash upwards and the sash will drive to the mid-position.
  - Manually tip the sash downwards and the sash will drive to the bottom position.
  - When the Auto Open feature is enabled, the sash automatically drives to the mid-position when the user is present.
  - There is a time delay following user detection.
-

- 
- When the Auto Lock feature is enabled and a Sash Lock position has been calibrated, the Auto Close feature is disabled and the sash locks in its current position when the sash is raised to the Sash Lock position or higher. This facilitates loading the Fume Cupboard.

- 
- When the Auto Stop feature is enabled the sash will stop at the middle calibrated position when manually opened. The sash can be raised above the middle position by holding the ↑ pushbutton for 2 seconds. This feature simulates a mechanical stop.

---

#### **Method C – 3 Positions**

- The bottom, mid and top positions are calibrated.
  - The sash automatically drives to the bottom position, when the user is not present.
  - Press the **Down** pushbutton to drive the sash to the bottom position, when the user is present.
  - Press the **Up** pushbutton to drive the sash to the next calibrated position, when the user is present.
  - When the Tiptronic feature is enabled, manually tip the sash upwards and the sash will drive to the next calibrated position.
  - Manually tip the sash downwards and the sash will drive to the bottom position.
  - When the Auto Open feature is enabled, the user is present and the sash is lower than the mid position, the sash automatically drives to the mid-position.
  - There is a time delay following user detection.
  - When the Auto Lock feature is enabled and a Sash Lock position has been calibrated, the Auto Close feature is disabled and the sash locks in its current position when the sash is raised to the Sash Lock position or higher. This facilitates loading the Fume Cupboard.
  - When the Auto Stop feature is enabled the sash will stop at the middle calibrated position when manually opened. The sash can be raised above the middle position by holding the ↑ pushbutton for 2 seconds.
-

#### 4.2.2 *Auto Sash Controller with Sash Low micro-switch*

A Sash Low Micro-Switch can be specified for fitting by TEL or by the fume hood manufacturer. The switch can be arranged to be open / closed when the sash is closed, depending on fitting. The wiring arrangement must be modified for installation and the operational requirements of the fume hood.

The following functionality is available:

- The sash automatically drives to the bottom position, when the user is not present.
- Press the **Down** pushbutton to drive the sash to the bottom position, when the user is present.
- The **Up** pushbutton is disabled.

#### 4.2.3 *Auto Sash Controller with Sash Low proximity switch*

A Sash Low Proximity Switch can be specified for fitting by TEL or the fume hood manufacturer. The switch can be arranged to be open/closed when the sash is closed, depending on fitting. The wiring arrangement must be modified for installation and the operational requirements of the fume hood.

The following functionality is available:

- The sash automatically drives to the bottom position, when the user is not present.
- Press the **Down** pushbutton to drive the sash to the bottom position, when the user is present.
- The **Up** pushbutton is disabled.

#### 4.2.4 *Auto Sash Controller DDA profile*

The sash controller can be set to operate a DDA style fume hood with a moveable base. A secondary sash position sensor is fitted to the base to detect the base position. Once a base movement has been detected, the calibrated sash open height from the base will be maintained when the sash is driven open, and the sash will close to the new base position when the sash is driven closed or auto closes and will give the following operation:

---

**DDA profile**

- The lowest and highest base and sash positions are calibrated.
  - The sash automatically drives to the bottom position, when the user is not present.
  - Press the ↓ pushbutton to drive the sash to the bottom position, when the user is present.
  - Press the ↑ pushbutton to drive the sash to the mid-position, when the user is present.
  - When the Tiptronic feature is enabled, manually tip the sash upwards and the sash will drive to the mid-position.
  - Manually tip the sash downwards and the sash will drive to the bottom position.
  - When the Auto Open feature is enabled, the sash automatically drives to the mid-position when the user is present.
  - There is a time delay following user detection.
  - When a base movement is detected new open and closed positions are set to maintain the calibrated opening height from the base and to stop the sash at the new base position.
-



### 4.3 Control system components

The Auto Sash Control System comprises of a control unit and additional components.

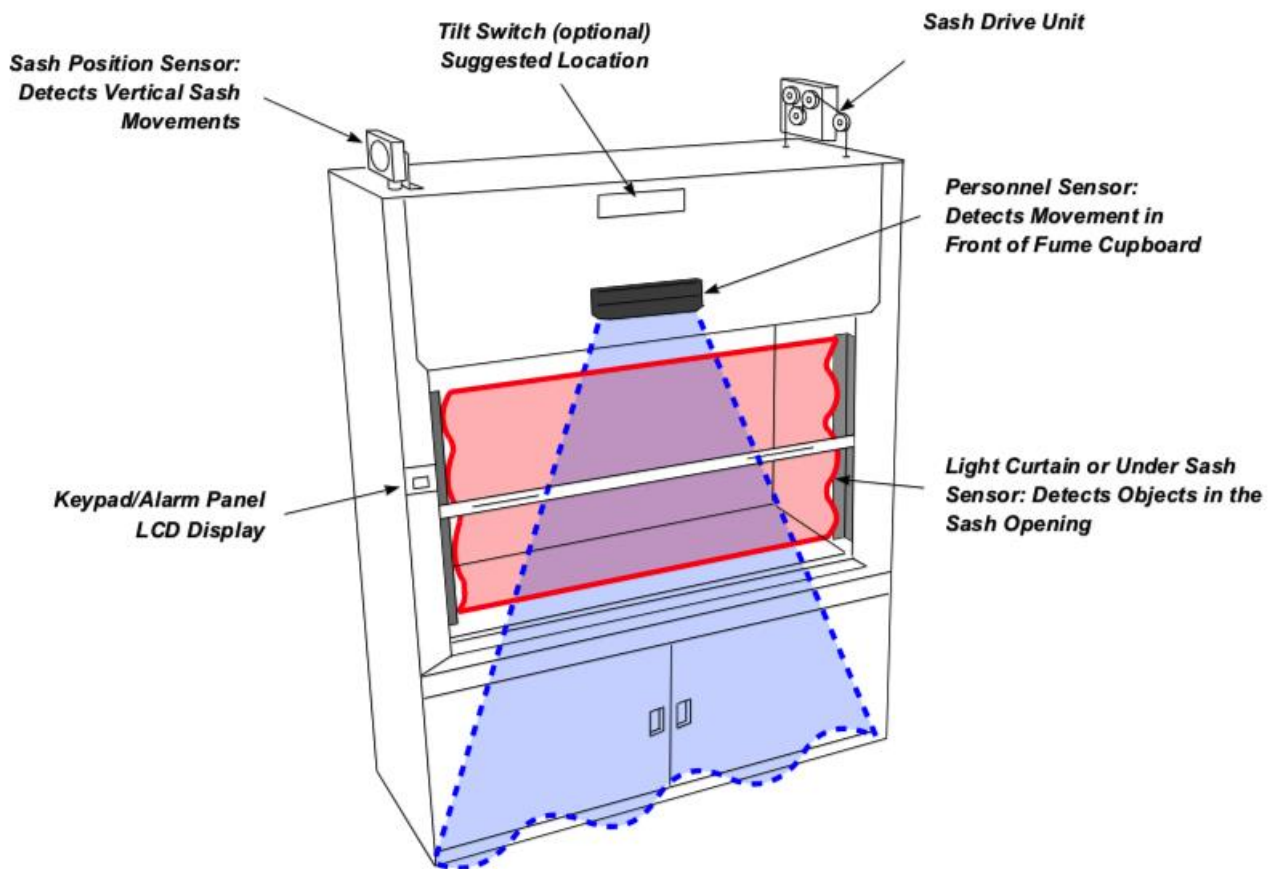

Figure 4: Typical location of main components

Note: This example installation is fitted with a pulley and wire sash drive.

### 4.3.1 Auto sash control unit

The Auto Sash Control Unit processes inputs from sensors, switches associated with the sash control function and output signals relevant to the motor drive(s) and the alarm panel.



Figure 5: Auto Sash Control Unit - single and dual controller enclosure

## 4.3.2 Personnel sensor



Green LED

Figure 6: Detection area clear



Red LED

Figure 7: Obstruction present

The Personnel Sensor is a Passive Infra-Red (PIR) occupancy detector which detects the presence / absence of the fume hood user.

*Note: If the user is detected, the sash will not automatically close. The Sash can be opened / closed manually or using the **Up** / **Down** pushbuttons.*

On power up, the Personnel Sensor 'learns' the reflection characteristics of the environment within its field of view and stores this information as reference background data. The sensor then 're-learns' the background every three minutes. A stationary object, such as a stool, that is left in the field becomes part of the background and is 'ignored' by the sensor. When the user is not present at the fume hood, the sash will close automatically. This follows a pre-set delay time, if the Sash Light Curtain is not broken and the sash is open.

## 4.3.3 Sash light curtain

The Sash Light Curtain is a safety device designed to detect whether the opening below the sash is clear of obstructions before the sash is automatically closed.

- When an obstruction is detected, the sash drive is disabled and the alarm is activated.
- The Sash Light Curtain comprises an infra-red transmitter mounted on one side of the fume hood and an infra-red receiver mounted on the opposite side of the fume hood's inner chamber.
- The infra-red transmitter has multiple, closely spaced, Light Emitting Diodes (LEDs) to facilitate the detection of small objects.
- Objects are detected when infra-red light from the transmitter is not detected by the receiver due to an obstruction in its path.



*Figure 8: Sash Light Curtain Transmitter and Receiver*

A separate Sash Light Curtain Control Box includes a sensitivity potentiometer that allows the beam sensitivity adjusted to sense glass or other objects that are partially transparent to infrared light.



*Figure 9: Sash Light Curtain Control Box*

#### **4.3.4 Under Sash sensor**

The Under Sash Sensor is an alternative to the Sash Light Curtain which detects whether the opening below the sash is clear from obstructions before the sash is closed.

A sensor on one side of the fume hood detects the reflection of a beam of light from a self-adhesive strip of retro-reflective tape mounted on the opposite inside wall of the fume hood.

The sensor incorporates a potentiometer, it allows the beam sensitivity to be adjusted to sense glass objects.

#### 4.3.5 Sash Low switch

When a Tiptronic control is not in use, a Sash Low switch is used to signal to the Auto Sash Control Unit that the fume hood sash is closed.

The switch can be either a mechanical roller lever type micro-switch or an inductive proximity switch.



*Roller Lever Micro-Switch*

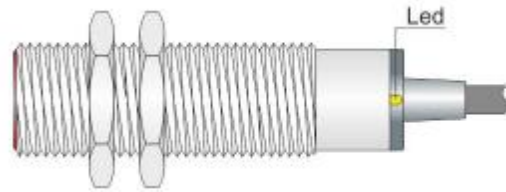

*Inductive Proximity Switch*

*Figure 10: Typical Sash Low switches*

#### 4.3.6 Sash Position sensor

The Sash Position Sensor comprises of a flexible cable, a spring-loaded spool and a potentiometer. It is used, in conjunction with the Tiptronic control option, to detect and measure vertical sash movement and the position of the fume hood sash.

During the initial on-screen calibration set up the sash controller detects the sensor direction of travel and then provides position information of the sash to the Auto Sash Control Unit, to enable calibration of the sash open / closed positions.



*Sash Position Sensor*



*Sensor Cable*



*Sensor Potentiometer*

*Figure 11: Sash Position Sensor*

### 4.3.7 Tilt switch

The Tilt Switch is an optional, third party supplied component, which is fitted to the fume hood top panel. It operates to isolate the Auto Sash controls, when the top panel is open to facilitate the servicing of the fume hood.

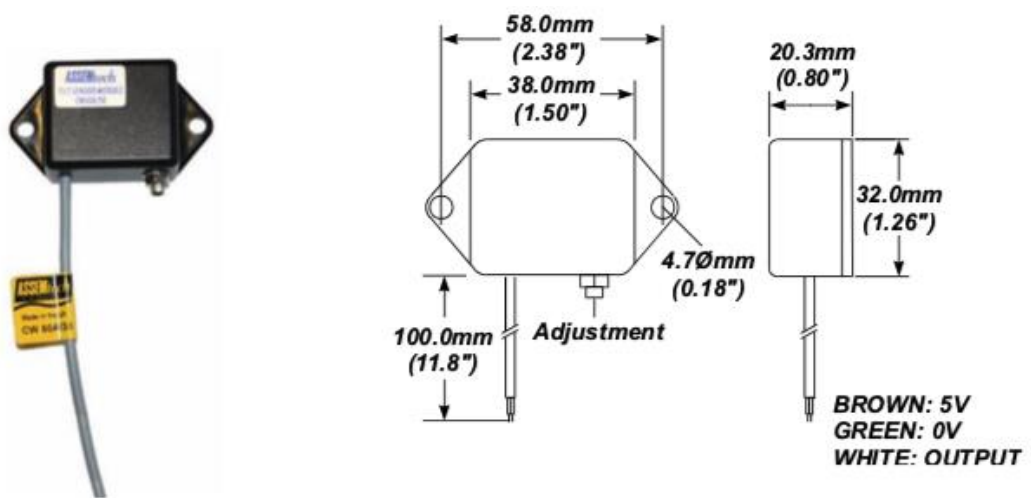

Figure 12: Typical third-party tilt switch

### 4.3.8 Foot switch

The Foot Switch is an optional, third party supplied component, which can be positioned on the floor in front of the fume hood and used to open the sash.



Figure 13: Typical third party foot switch

### 4.3.9 Sash drive unit

The Sash Drive Unit is a geared electric motor and clutch assembly used to drive the sash.

Three types of drive are available, none of which preclude manual opening / closing:

- Rack and pinion drive
- Chain and sprocket drive
- Pulley and wire drive



Chain and sprocket drive



Rack and pinion drive



Pulley and wire drive

Figure 14: Example drives

## 5. *Installation: Airflow Monitor*

This section outlines the installation of the various components of the airflow monitor system. The size and format of individual fume cupboards varies considerably, so specific instructions are not possible, however the principles outlined are valid for all cases.

### 5.1 *Location*

The AFA4000/E monitor can be mounted on either side of the fume cupboard. However, when deciding on the location for the airflow monitor, sensor and Econ Power Supply Unit (PSU), consider the cable lengths required:

- The 14-way ribbon cable must be able to connect the Econ Power Supply Unit when it is fitted to the top of the fume cupboard to the AFA4000/E controller.

*Note: Longer ribbon cables are available on request.*

- The mains ac power cable from the Econ Power Supply Unit must be able to reach a suitable power socket.
- The standard 2 metre 'telephone style' sensor cable must reach from the back of the AFA4000/E airflow monitor to the airflow sensor. When possible ensure that the airflow sensor is mounted on the same side of the fume cupboard as the AFA4000/E.

*Note: Longer sensor cables are available on request.*

*Note: The Econ VAV damper can be mounted in any orientation, but take into consideration the access required to the damper for future maintenance.*



## 5.1.1 SM7 airflow sensor installation notes

It is very important to position the SM7 airflow sensor in the correct position to give a long-term stable reading of the face velocity.

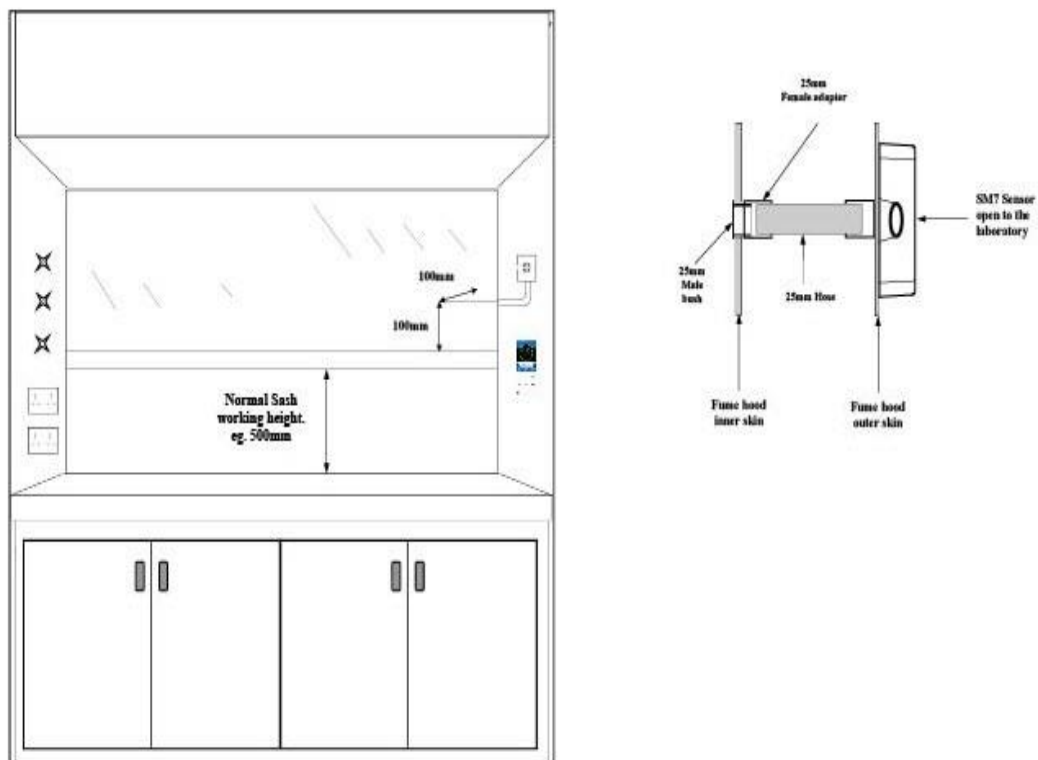

Figure 15: Airflow sensor installation diagram

Please read the notes below and if in doubt contact us for further advice.

1. The SM7 sensor must be positioned where it can sense the room pressure of the laboratory. The back-connection spigot of the sensor is designed to accept a tube with outside diameter of 25 mm, which should be connected to the inner chamber of the fume cupboard. This tube and fittings are known as the 'vent kit'.  
The ideal position for the end of the 25 mm diameter tube, for most fume cupboards, is 100 mm back from the sash glass and 100 mm higher than the normal sash opening height through the inner side wall.
2. If possible, mount the sensor on the front of the fume cupboard and use a short length of tube. Tube lengths of more than 1 m or smaller diameter will restrict the airflow through the

sensor. This will lead to too much sensitivity being required to calibrate the unit which can lead to instability of the readings or incorrect readings at low velocities.

3. For fume cupboards with a single-skin side-wall, or double-skin, with a small gap between them, it may not be possible to achieve the ideal sensing position using a flexible tube.

With a single-skin side-wall it is possible to fix the sensor on the outside of the fume cupboard and connect directly to the inner chamber in the ideal position. This method can only be used for up to two fume cupboards when they are positioned side by side, using the two outer walls.

An alternative method is to mount the sensor on the front of the fume cupboard and connect it using a short flexible tube to a rigid wall tube attached to the inner side-wall. Position the open end of this rigid wall tube in the 'ideal position' for example, 100 mm back from the sash, and 100 mm higher than the normal sash opening.

Fume cupboards with a large internal height can present a difficulty because the tube length to reach the ideal position may be longer than 1m. Where possible, use a tube of 1 metre or less, which may result in a sensing position higher than the ideal.

When fitting a sensor to a 'narrow wall' fume cupboard for the first time, it may be necessary to try various combinations of rigid and flexible tube to find the best combination and position.

4. The sensor should not be mounted in a position where it is subject to draughts from the laboratory air input or ventilation system.

## 5.2 *Installation*

### 5.2.1 *AFA4000/E*

1. Use the cut-out details provided with the unit (Figure 16) to cut out and drill the holes in the fume cupboard for the AFA4000/E mounting bracket.

Make sure that the AFA4000 fits into the cut-out before proceeding.

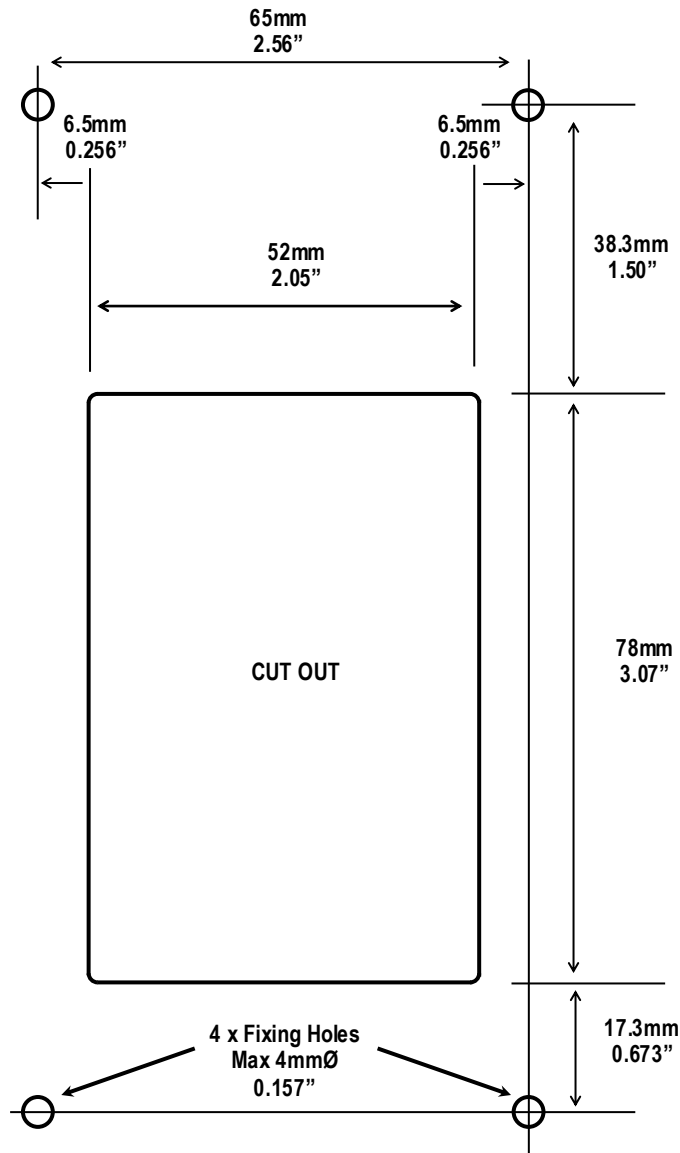
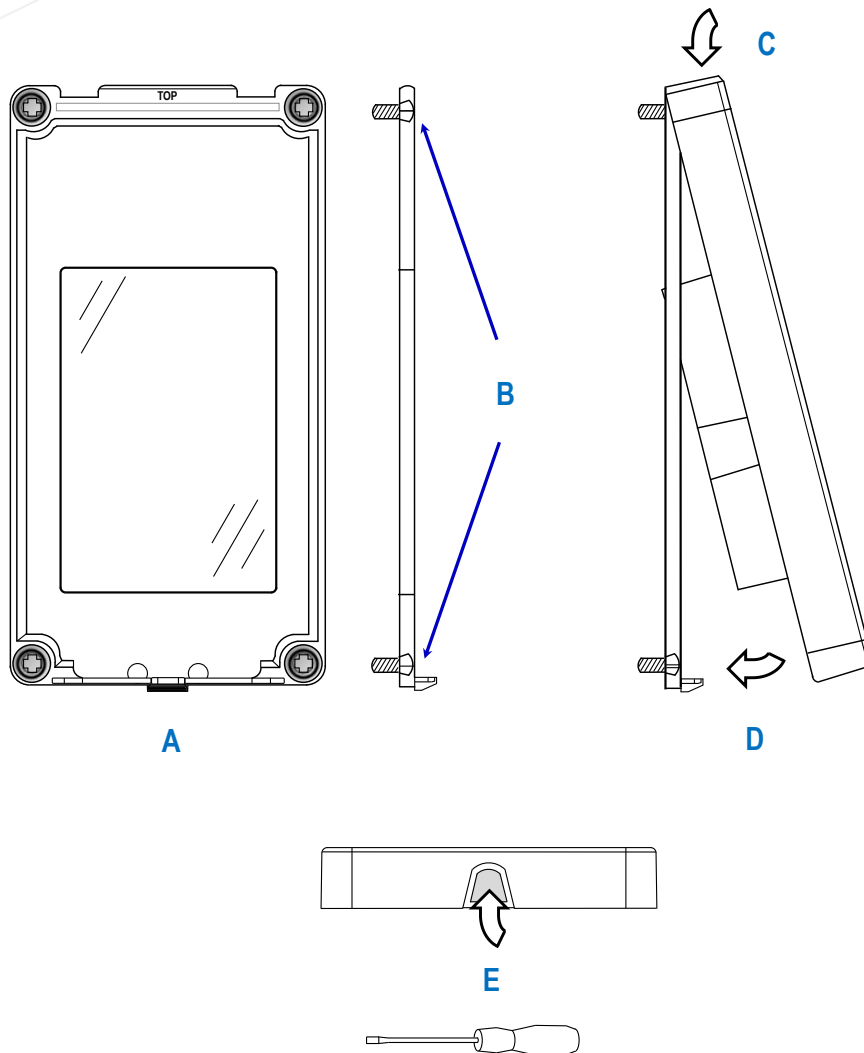

Figure 16: AFA4000 cut-out template

Note: Print to A4. Do not scale or print to fit page.

Note: Separate mounting boxes and adaptor plates are available for retro-fitting to older fume cupboards.



*Figure 17: AFA4000 installation*

2. Use 4 fixing screws to secure the mounting bracket to the front panel of the fume cupboard (A in figure 17).  
Make sure the 4 fixing screws are fully recessed into the counter-sunk fixing holes (B in figure 17).
3. Place the AFA4000 onto the top of the mounting bracket (C in figure 17).
4. Push the bottom of the AFA4000 onto the mounting bracket and click into place (D in figure 17).
5. To remove the AFA4000 press the latch on the bottom edge. A screwdriver or blunt tool can be used if required (E in figure 17).
6. Fit the Econ Power Supply Unit to the top of the fume cupboard.
7. Fit the airflow sensor to the fume cupboard (section 5.2.2).

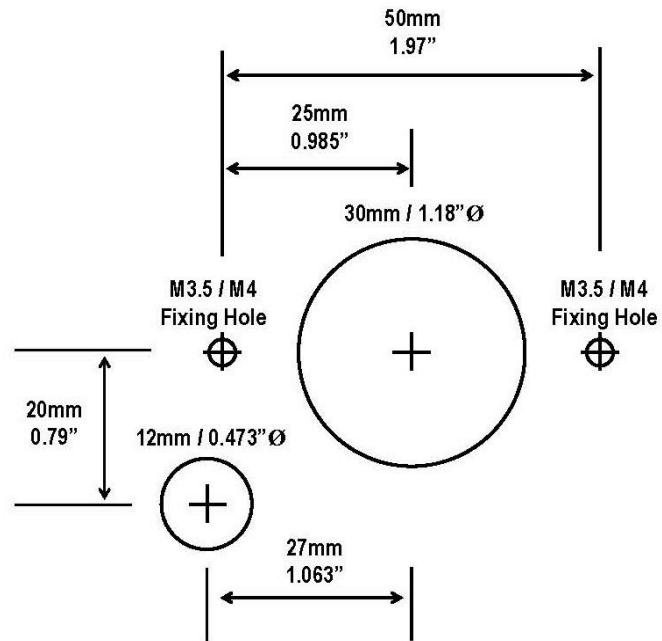

Figure 18: SM7 sensor cut-out template

Note: Print to A4. Do not scale or print to fit page.

## 5.2.2 Typical installation diagrams

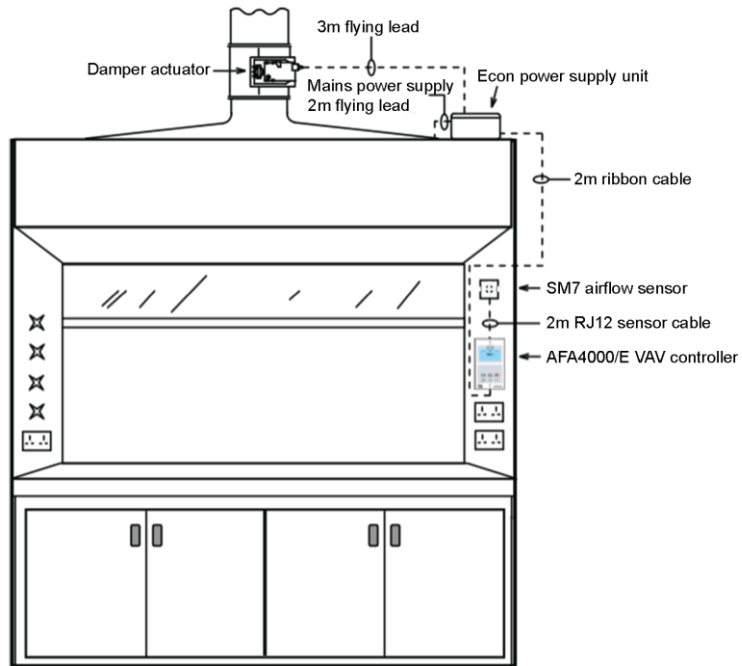

Figure 19: Typical double-wall style fume cupboard installation

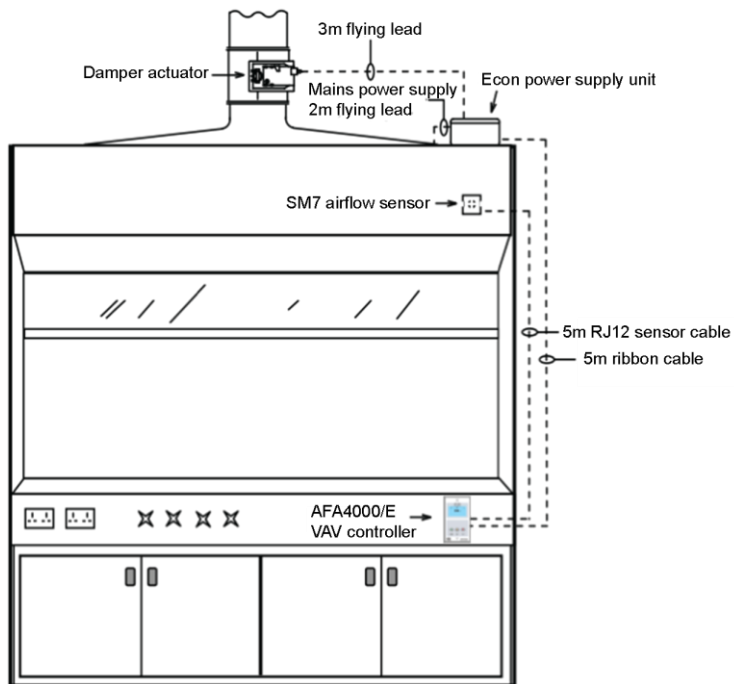

Figure 20: Typical Euro single-wall fume cupboard installation

## 5.3 Connections

1. Connect the 14-way ribbon cable to the Econ Power Supply Unit on top of the fume cupboard and to the Relay Interface Unit connector on the back of the AFA4000/E monitor (K in Figure 21).
2. Connect the 'telephone style' airflow sensor plug-in cable to the sensor and the back of the AFA4000/E unit (J in Figure 21).
3. For damper control, terminate the damper actuator cable into the ECON Output 1 terminals on the Econ Power Supply Unit. Use a 20 mm cable gland to secure the cable to the power supply box. Figure 23 shows the connections for damper control.
4. For inverter control, refer to Figure 22.
5. Connect the power supply cable into the back of the AFA4000/E (H in Figure 21) and to the connection on top of the fume cupboard.

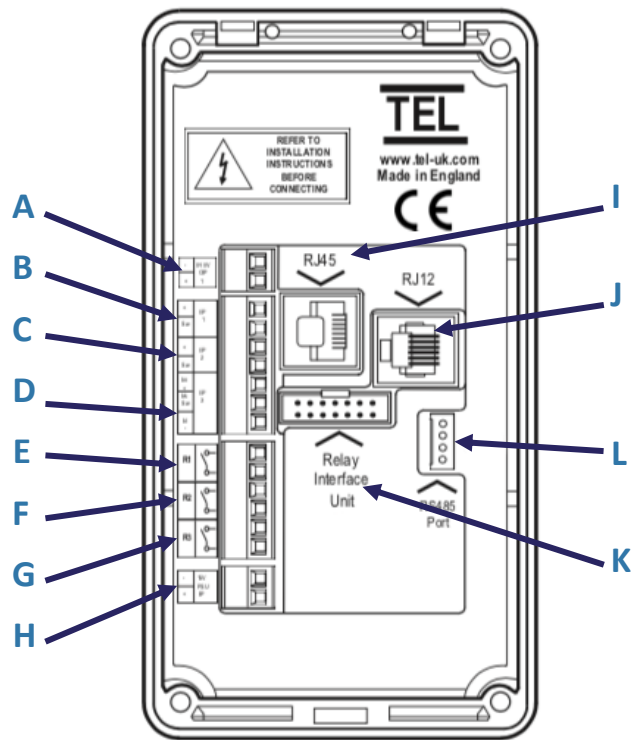

Figure 21: AFA4000/E and AFA4000/E/AS monitor connections

A	0-10 V Econ Output 1 (used if relay interface is not fitted)	G	Relay output 3 (used if relay interface is not fitted)
B	Input 1 – digital or analogue	H	15 Vdc power supply (used if relay interface is not fitted)
C	Input 2 – digital or analogue	I	Auto sash RJ45 connection (only used on AFA4000/E)
D	Input 3 – digital or analogue	J	Airflow sensor RJ12 connection
E	Relay output 1 (used if relay interface is not fitted)	K	14-way ribbon cable connection to relay interface
F	Relay output 2 (used if relay interface is not fitted)	L	RS485 comms port connection



## AFA4000/E AIRFLOW CONTROLLER

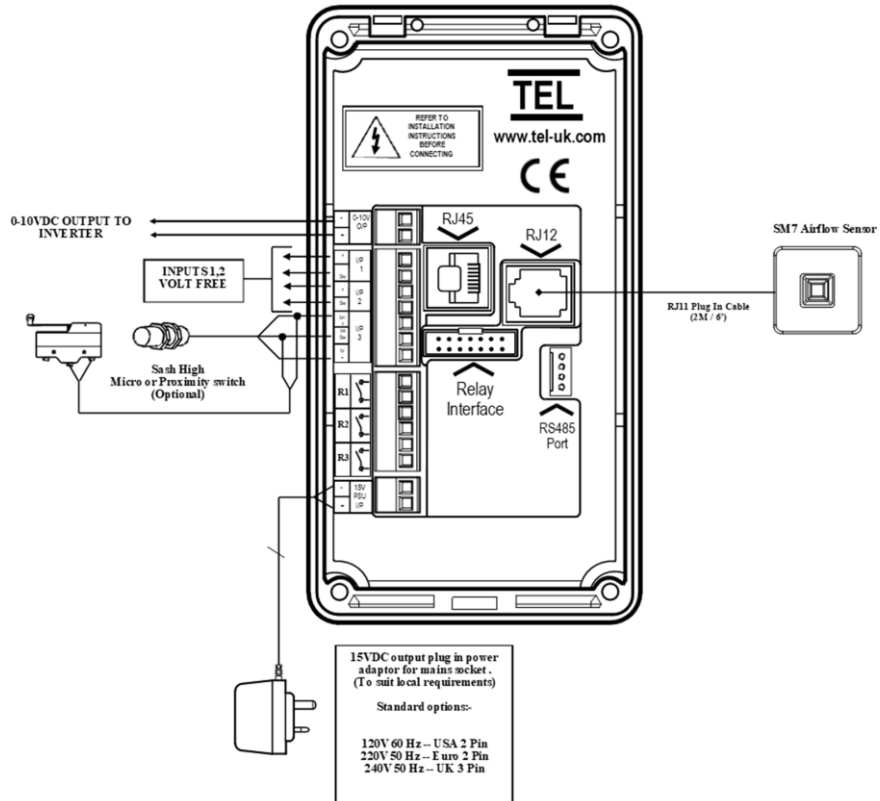

Figure 22: AFA4000/E inverter control connections



## AFA4000/E VAV CONTROLLER

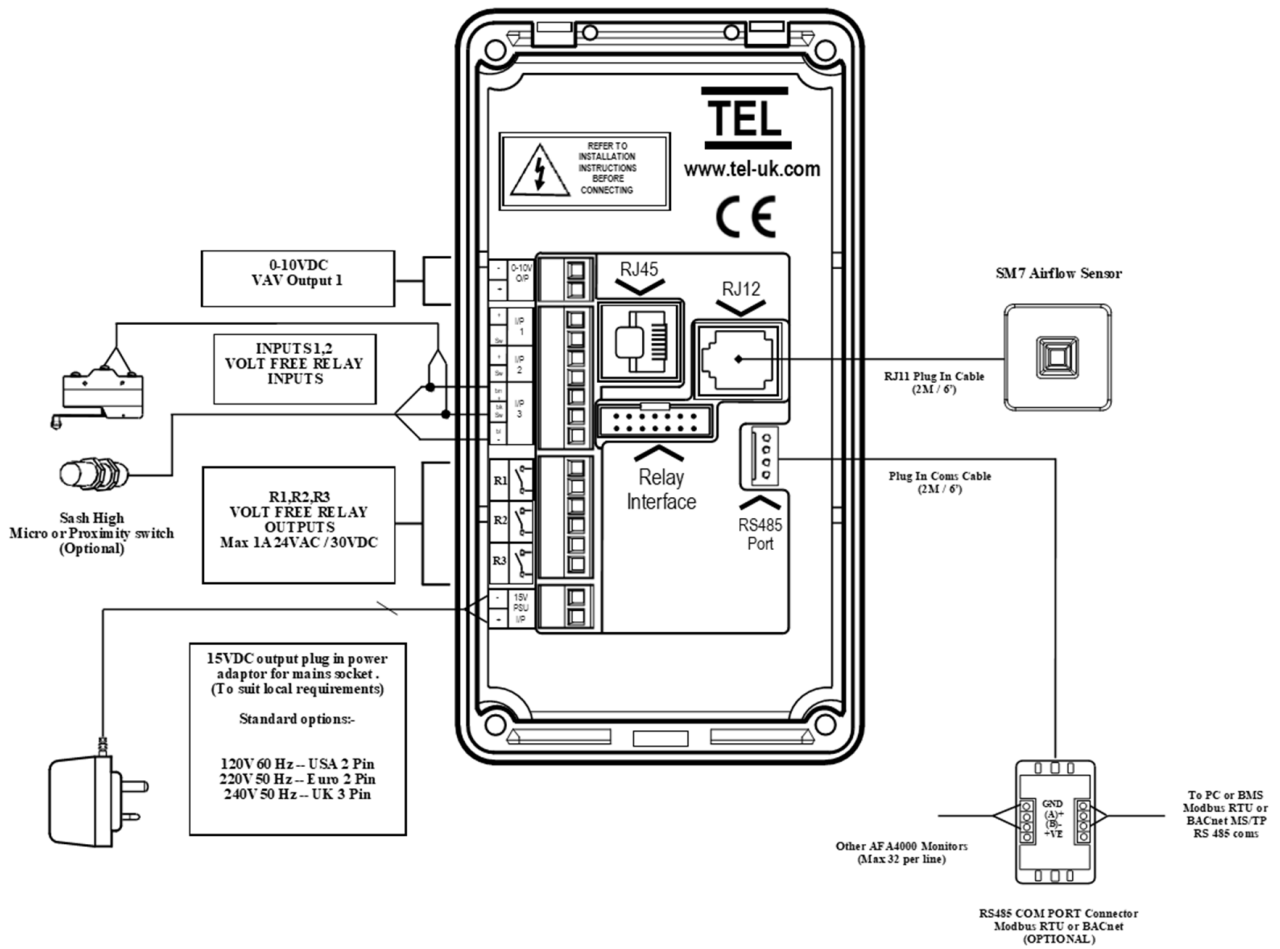

Figure 24: AFA4000/E typical connection diagram



## 5.4 Dimensions

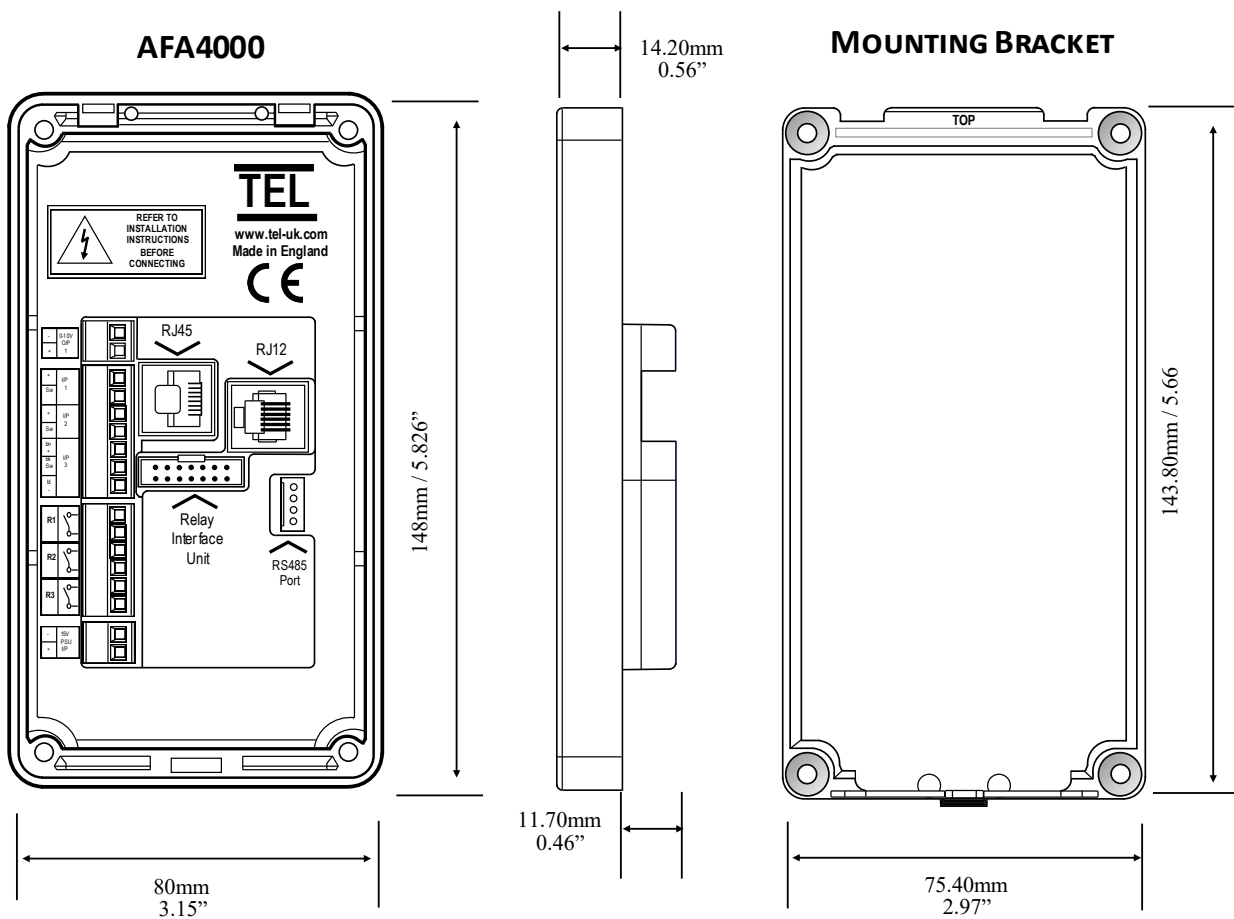

Figure 26: : AFA4000/E and AFA4000/E/AS dimensions

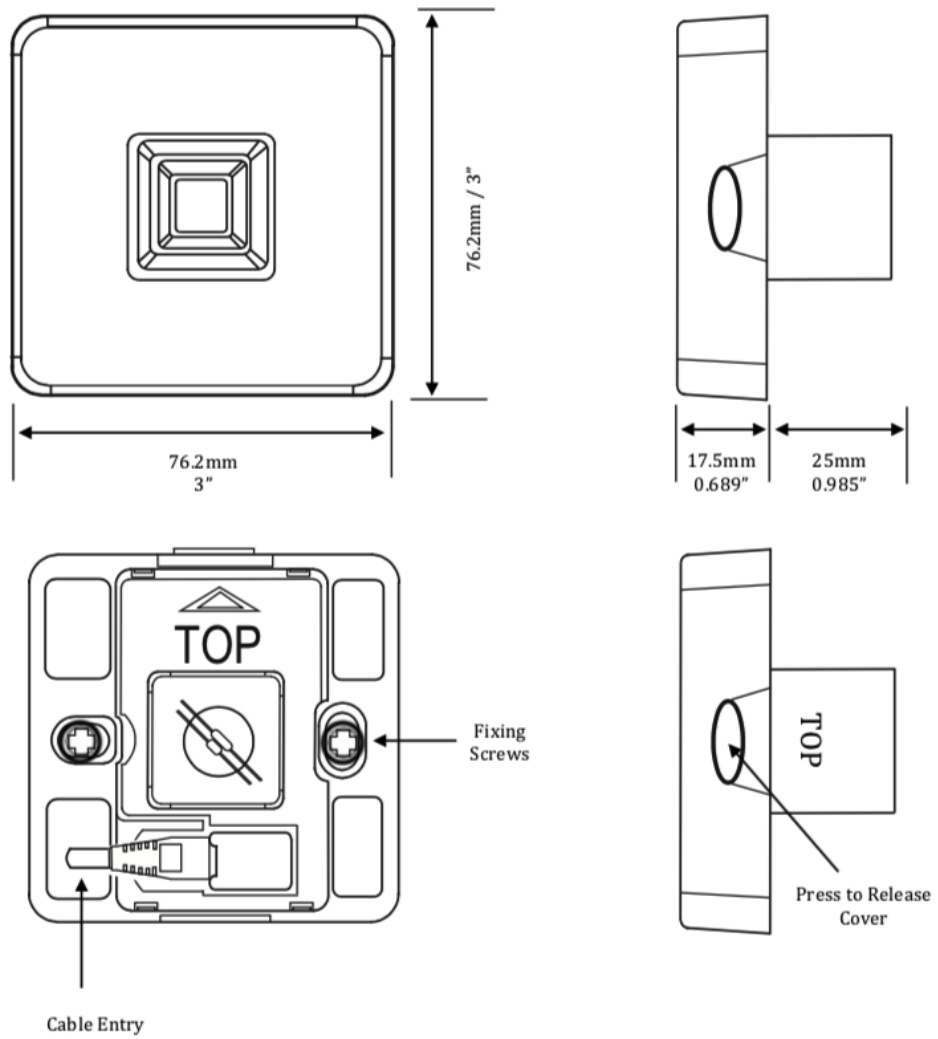

Figure 27: SM7 airflow sensor dimensions

## 5.5 Start up

### 5.5.1 AFA4000/E

The AFA4000/E must be field-calibrated once the room air supply and exhaust is proportionally balanced.

When the unit is powered up, the following sequence of events occurs:

1. The alarm performs a self-test of its functions and audible alarm which takes approximately 5 seconds.
2. At the end of the delay, the unit will do one of two things:
  - When the Airflow monitor has been calibrated, the unit enters normal operating mode. The monitor displays airflow velocity, LEDs and the audible alarm is enabled.
  - If the Airflow monitor has not been calibrated, the unit displays the message *Requires set up, press Mute to continue*.

*Note: If the unit has been fitted with a Fan Stop/Start pushbutton, the controller can be set to Run mode before it is calibrated to allow the fan to be started. To enter the menu from the Run screen, press and hold the Mute button for 5 seconds or until the main menu appears.*

*Note: During set-up, all alarms and output relays are inhibited.*

Follow the instructions in the *Calibration* section (section 7.1).

### 5.5.2 AFA4000/E/AS

The AFA4000/E/AS must be field-calibrated once the room air supply and exhaust is proportionally balanced.

When the unit is powered up, the following sequence of events occurs:

1. The alarm performs a self-test of its functions and audible alarm which takes approximately 5 seconds.
2. At the end of the delay, the unit will do one of five things:
  - When the Airflow monitor has been calibrated, the unit enters normal operating mode (Run). The monitor displays airflow velocity, LEDs and the audible alarm is enabled.
  - When the Airflow monitor has not been calibrated, the unit displays the message *Requires set up, press Mute to continue*.

- When the Auto Sash Controller has been calibrated, the unit enters normal operating mode. The Controller displays status and alarms in the status window.
- When the Auto Sash Controller is connected and has not been calibrated, the status window displays the message *Auto Sash Not Configured*.
- When the Auto Sash Controller is disconnected, the Auto sash controller status and menus are not displayed.



## 6. Installation: Auto Sash Controller

As the size and format of individual fume hoods vary, the installation instructions that follow are general. The principles outlined should remain valid in all cases.

*Note: Before starting installation, ensure that the sash is free to move in its runners. Use silicon spray on the sash runners or adjust the sash runner's alignment when the sash does not move freely.*

### 6.1 Auto Sash Control Unit

#### 6.1.1 Mounting the unit

The Auto Sash Control Unit can be mounted as follows:

- Screwed flat to the outside of the fume hood roof - horizontal mounting

*Note: For horizontal mounting, the control box should always be mounted with the lid / front panel facing upwards.*

- Screwed to the outside wall of fume hood wall - vertical mounting



Figure 28: Auto Sash Control Unit Lid/Front Panel



Figure 29: Rear of Auto Sash Control Unit



*Figure 30: Auto Sash Control Unit Connectors, Single and Dual Fume Hoods*

Once the Auto Sash Control Unit has been positioned, mark its position using the fixing holes in the rear of the housing as a template. Then, attach the Auto Sash Control Unit using screws.

### **6.1.2** *Wiring in the Auto Sash Control Unit*

For fume hoods with an inner and outer sidewall, route all cables through the sidewall and into the service void.

For fume hoods with a single wall, route all cables up the outside of the sidewall, using suitable trunking or fixing pads and ties.

When wiring in the Auto Sash Control Unit, observe the following:

- Keep cables clear of moving parts.
- Use grommets wherever cables pass through sidewalls to prevent abrasion of the cable insulation and / or sidewall. Where a cable is supplied with a DIN connector, the grommet should have a minimum internal diameter of 17mm (0.67").
- Do not overstress cables by bending, for example when passing at 90° through a sidewall.

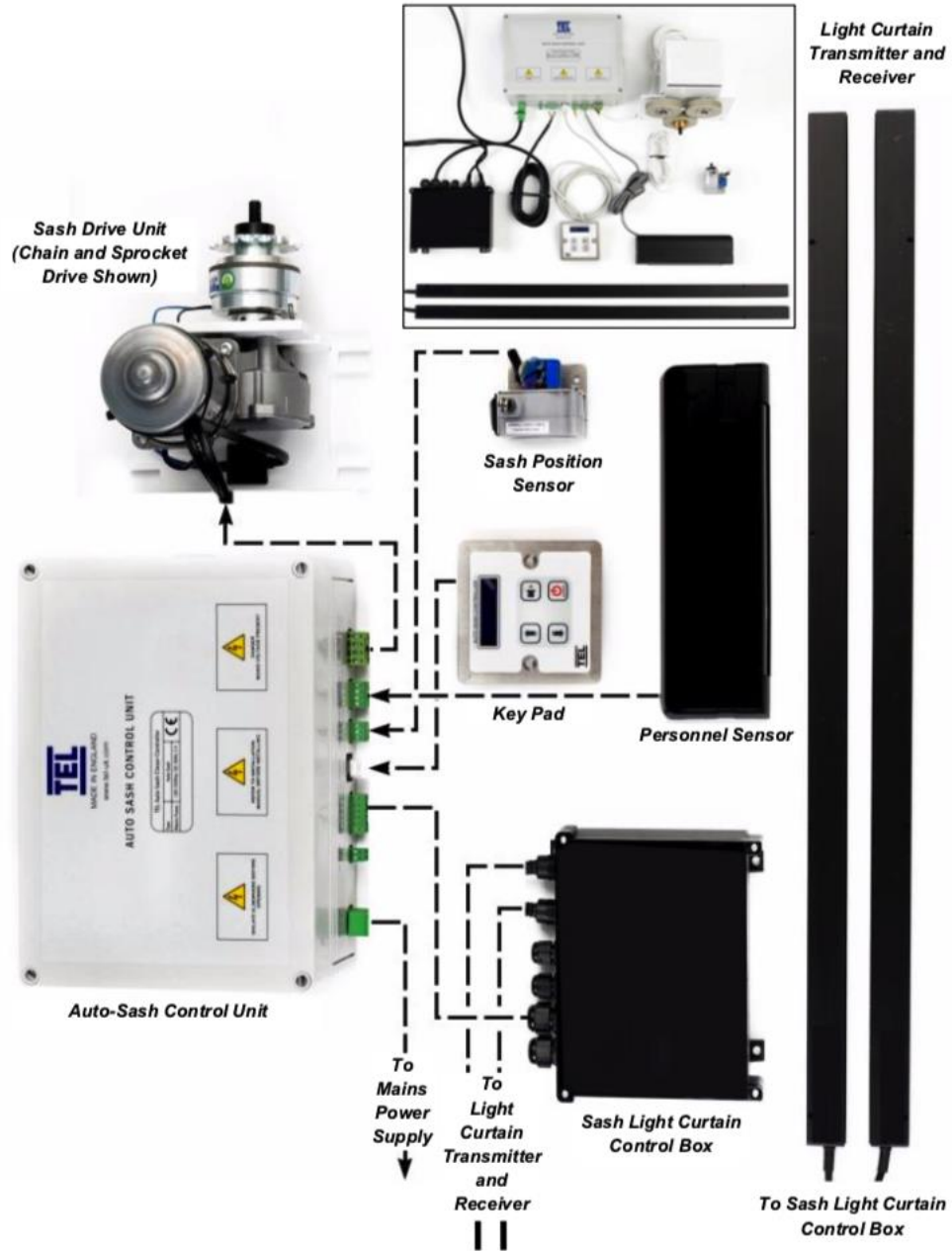

Figure 31: Sash Control System – general layout, wiring schematic and illustration (inset)

### Cable Specifications

Mains cable	3-core, 0.7mm <sup>2</sup> , 2m long
Light Curtain cable	4-core, 0.5mm <sup>2</sup> , 2m long
Keypad cable	RJ45, 3 m long
Sash Position Sensor cable	4-core, 0.2mm <sup>2</sup> , 2.5m long
Personnel Sensor cable	5-core, 0.2mm <sup>2</sup> , 3m long
Motor cable	2-core, 0.5mm <sup>2</sup> , 2m long

## 6.2 *Auto Sash motor drive unit*

A Motor Drive Unit is used to automatically raise and lower the fume hood sash.

Three types of drives are available:

- Rack and pinion motor drive.
- Chain and sprocket motor drive.
- Wire and pulley motor drive.

The optimal choice of sash drive type depends on whether:

- The installation is part of a new build or retro-fit.
- The size and configuration of the fume hood.
- The fume hoods location.

None of these options preclude manual operation of the sash.

### 6.2.1 *Rack and pinion motor drive*

The Rack and Pinion Motor Drive uses a rack fitted directly onto the sash frame and a motor drive assembly fitted to a framework above the fume hood.

This drive system is ideal for retro-fit installations where there is no access to the sash wires or counterweights and / or where the sash is fitted to a metal framework, for example combination type sash fume hoods.

#### 6.2.1.1 *Installing the rack and pinion drive*

1. Raise the sash to the fully open position.
2. Offer up the motor assembly and rack to ensure that there is a clearance of at least 1.2 m (47.24") above the top of the sash.

*Note: The rack is supplied in 1m (39.37") lengths*

3. The motor drive assembly should be fitted to a rigid framework and positioned centrally above the sash. To ensure that the T-bar fixing clears the bottom of the motor assembly, there should be at least 50 mm between the top of the sash and the bottom of the motor drive assembly, when the sash is fully opened.

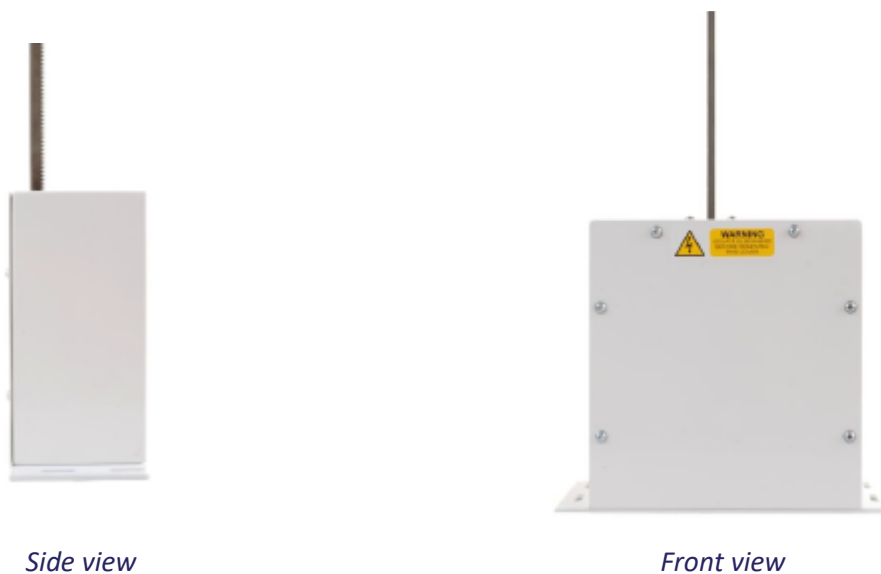

*Figure 32: Rack and pinion sash drive motor assembly*

*Note: Ensure that the rack is long enough to protrude through the top of the motor assembly, when the sash is fully closed.*

4. When the motor drive assembly is fixed to the fume hood the T-bar should be fixed to the rack and offered up with the sash frame.
5. Ensure that the rack is free to move over the full sash opening before marking up and fixing the T-bar to the sash frame.

*Note: The rack must to run vertically at 90° to the horizontal axis of the sash frame.*

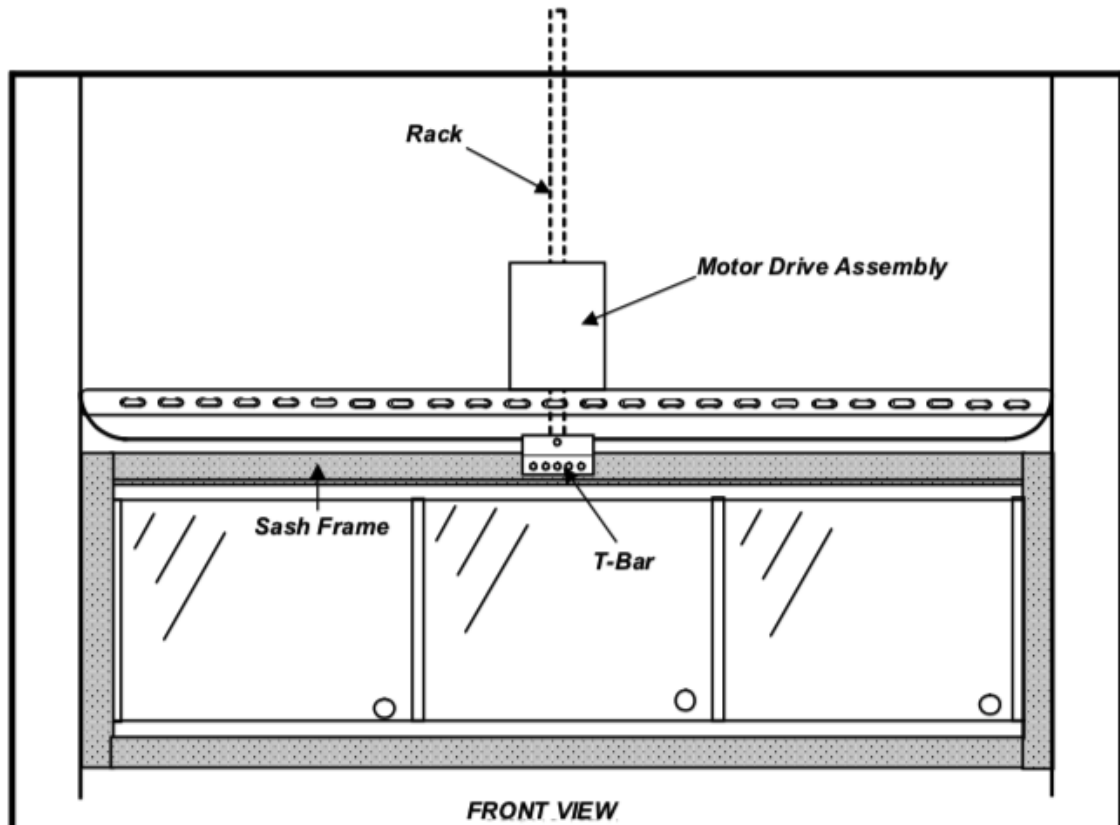

Figure 33: Front view of rack and pinion sash drive

6. When fitting a sash low switch instead of a sash position sensor, the rack will need to be cut to the correct length to enable the switch to operate.  
Close the sash fully and mark the rack just below the position of the proximity low switch at the top of the motor assembly to ensure that the rack is clear of the switch when the sash is closed.
7. Connect the Sash Drive to the Auto Sash Control Unit using the cables provided (with red and black connectors). See the wiring schematic in section 6.9.  
*Note: It is important to observe the correct polarity when making electrical connections.*
8. Connect the clutch assembly to the Auto Sash Control Unit using the cables provided (with blue and yellow connectors).

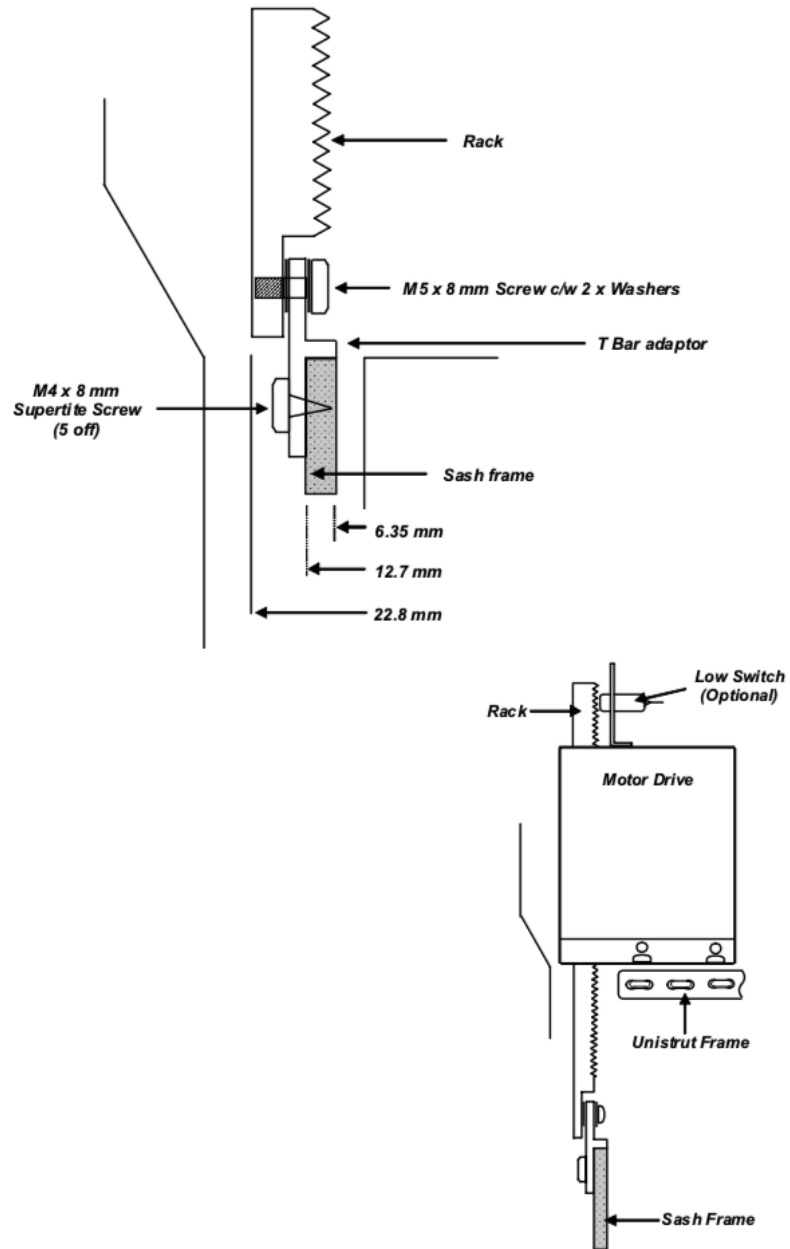

Figure 34: Side views of a rack and pinion drive typical installation

## 6.2.2 Chain and sprocket drives

Two types of chain and sprocket drives are available:

- Shaft Drive
- Counterweight Drive

### 6.2.2.1 Chain and sprocket shaft drives

In the Shaft Drive arrangement, the motor drive utilises a taper bore sprocket and a roller chain to drive a shaft running between the counterweight pulleys.

The motor assembly is supplied fitted to an adjustable bracket so that the correct chain tension can be set.

The Shaft Drive arrangement can accommodate one or two sash wires.

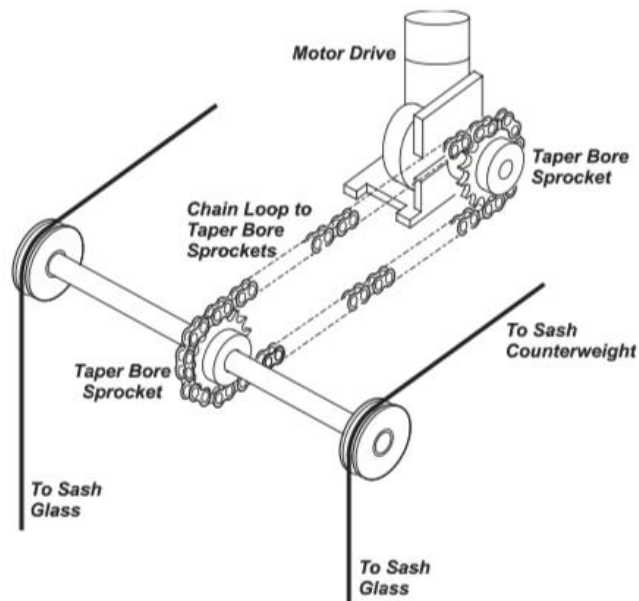

Figure 35: Typical chain and sprocket shaft drive installation

### 6.2.2.2 Installing the chain and sprocket shaft drive

1. Fit the taper bore sprocket to the shaft and ensure that the sprocket is securely fitted.  
Where possible position the motor drive and sprocket centrally on the shaft. The motor assembly should be fitted to a rigid framework to support the motor.
2. Loosely fit the chain before fixing the motor plate to ensure the chain is correctly tensioned and aligned.



### 6.2.2.3 Chain and sprocket counterweight drive

In the Counterweight Drive arrangement, the chain and sprocket drive system is used to directly lift the sash counterweight. This is achieved by fitting a roller chain to the counterweight and utilising a separate counterweight and freewheeling sprocket to maintain the correct chain tension.

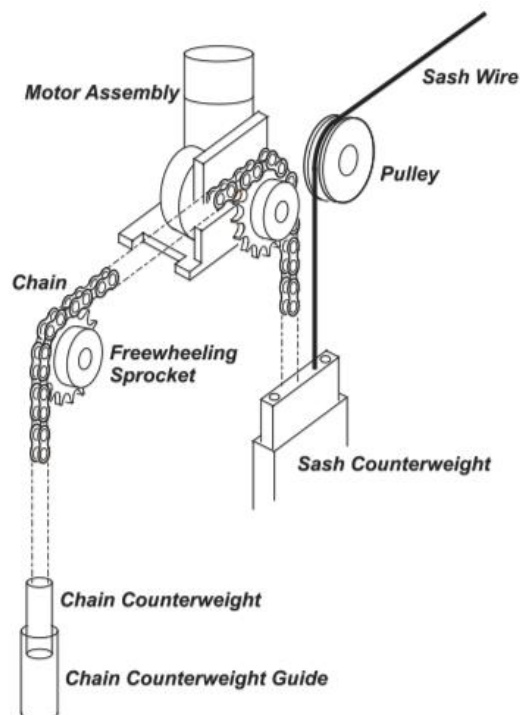

Figure 36: Typical chain and sprocket counterweight drive installation

### 6.2.3 Installing the chain and sprocket counterweight drive

1. When the motor, chain and freewheeling sprocket has been fitted, manually open / close the sash, to ensure that the motor drive is free running and that the chain is not too slack or too tight.
2. Fit the motor so that the drive sprocket is in line with the counterweight pulley.
3. Fit one end of the chain to the counterweight or sash wire near to the counterweight.
4. Fit the freewheeling sprocket in line with the drive sprocket.
5. Loosely fit the chain over the freewheeling pulley and determine the best position for the chain counterweight.
6. Fit the chain counterweight, using a counterweight guide if necessary.

7. When the motor, chain and counterweight are fitted manually open / close the sash to ensure the motor drive, chain and counterweight are free running.

## 6.2.4 Wire and pulley drive

With the Wire and Pulley Drive, the pulley motor drives the sash wire and can accept both single and dual sash wire systems. The motor assembly is fitted in line with the sash wires and uses two guide pulleys and a drive pulley.

The pulley drive is ideal for new fume hoods but can be retro-fitted if a longer replacement sash wire can be fitted.

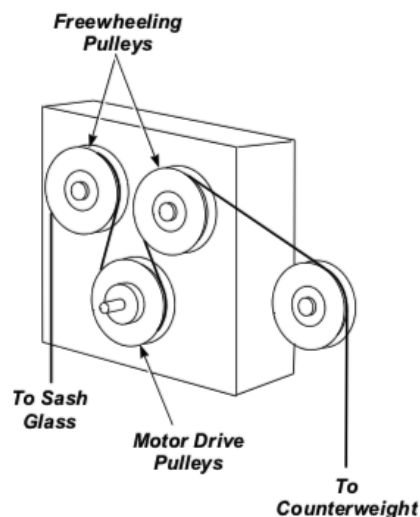

Figure 37: Typical wire and pulley drive installation

### 6.2.4.1 Installing the wire and pulley drive

The motor assembly can be fitted horizontally or vertically on either side of the fume hood, as follows:

1. Fit the motor assembly so that the guide pulleys are in line with the sash wire.
2. Run the sash wire over the first guide pulley, around the drive pulley and then over the final guide pulley.

When the motor drive has been installed, open / close the sash to ensure that the sash can travel freely.

## 6.3 Sash light curtain

The Sash Light Curtain consists of three main components and associated wiring:

- Sash Light Curtain Control Box
- LED Transmitter
- LED Receiver

The Sash Light Curtain Control Box is connected to the main Auto Sash Control Unit.

### 6.3.1 *Installing the sash light curtain control box*

1. Fix the Sash Light Curtain Control Box onto the top of the fume hood, using the tabs attached to the control box and the screws provided. Ensure that there is access to the terminals to connect the wiring.

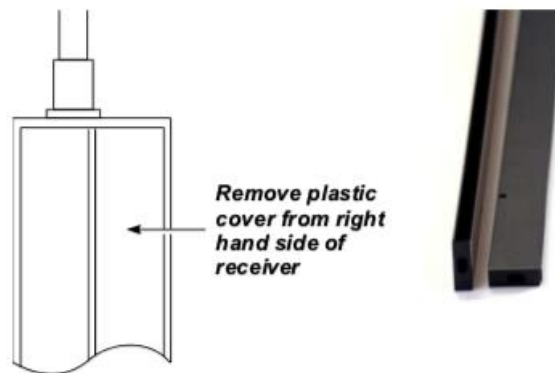

*Figure 38: Sash Light Curtain Control Box*

2. Use the pre-assembled cables and connectors supplied to connect the Light Curtain Control Box to the Auto Sash Control Unit. See the wiring schematic in section 6.9.

## 6.3.2 *Installing the sash light curtain transmitter and receiver*

1. Find a suitable position near to the back of the sash track. Ensure that the sash handle does not protrude into the light beam and that there are no other obstructions on either side wall.
2. Carefully remove the front plastic covers from the right-hand side of the light curtain receiver and the left-hand side of the light curtain transmitter cases.



*Figure 39: Light curtain receiver plastic cover*

3. Position the light curtain transmitter and receiver on opposite sidewalls. Ensure that the back of the sash handle does not penetrate the light beam path.  
The sash light curtain transmitter and receiver should be fitted so that their cable entry / exit points are at the top.  
Ensure that the light beam path is free from other obstructions.

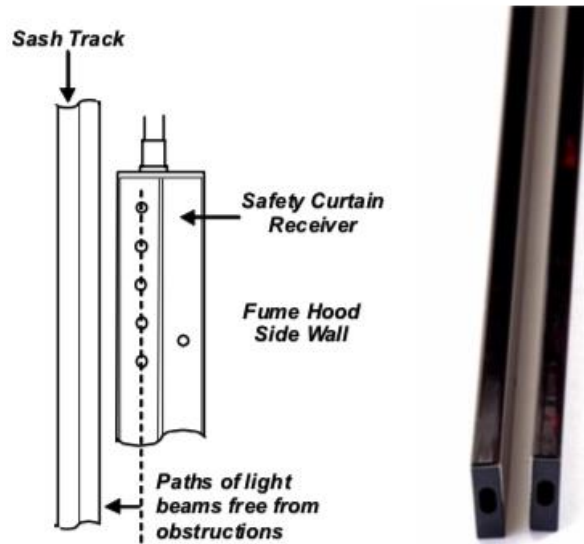

Figure 40: Mounting transmitter / receiver

### 6.3.3 *Aligning the light curtain transmitter and receiver*

Mount the light curtain receiver and transmitter at the same height on opposing sides of the fume hood opening. A small error in alignment is acceptable. The allowable error is dependent on the spacing between the transmitter and receiver.

Figure 41 illustrates the maximum allowable transmitter to receiver misalignment / displacement for a 0 to 3 m (0 to 118.11") range of fume hood widths. For a typical fume hood width of 1 to 2 m (39.37 to 78.740"), the maximum allowable misalignment / displacement ranges from approximately 20 to 40 mm (0.79 to 1.58").

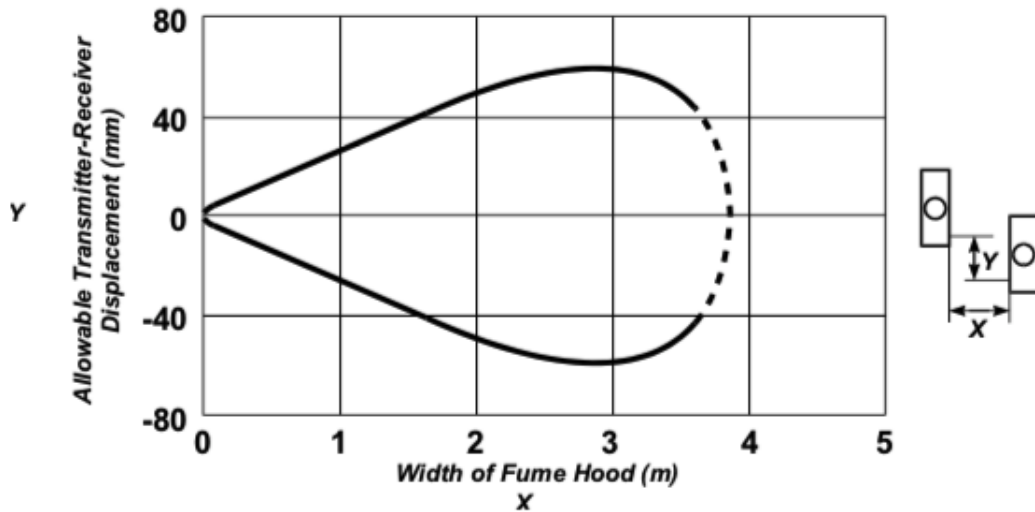

Figure 41: Maximum allowable displacement for a range of fume hood widths

1. The area protected by the light beams should cover the open area under the sash, typically 500 mm (20") from its base.

The light curtain transmitter and receiver can be positioned above the bottom of the sash in the fume hood if they are free from obstructions.

Where possible, make sure the light path is aligned flush to the bottom of the sash base.

*Note: There is a 123 mm (4.84") gap from the top of the light curtain transmitter to the first LED down and a 22 mm (0.87") gap from the bottom of the transmitter to the first LED up.*

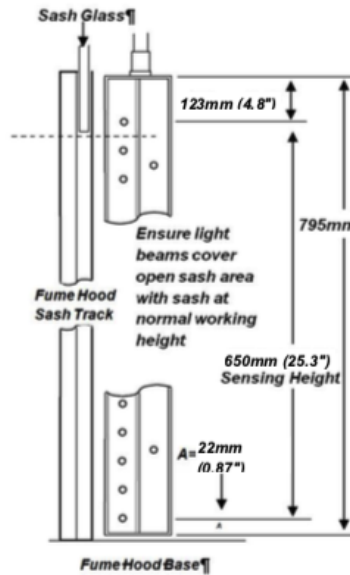

Figure 42: Light curtain vertical range

2. When the light curtain transmitter and receiver have been positioned, mark the sidewall using the fixing holes in the transmitter and receiver as templates.
3. Drill the holes for the fixing screws. Use the 2 mm (0.08") drill bit provided and fix the transmitter and receiver.

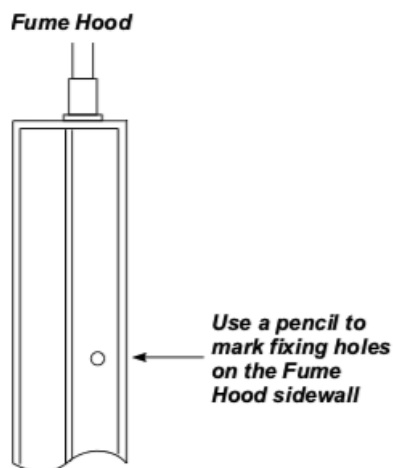

Figure 43: Transmitter / Receiver fixing holes

4. On a fume hood with an inner and outer sidewall the light curtain transmitter and receiver cables run through the sidewall into the service void and up to the Sash Light Curtain Control Box on top of the fume hood.

On a fume hood with a single wall drill the hole in the top soffit panel and run the cables up the sidewalls using suitable trunking or fixing pads and ties.

Drill a 17mm (0.67") hole to clear the cable DIN connector.

When using a grommet drill a suitable hole in the sidewall to accept the grommet.

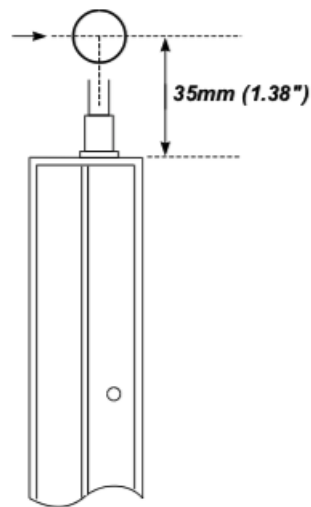

*Figure 44: Light curtain cable entry*

*Note: The hole's centre should be a minimum of 35 mm (1.38") from the top of the light beam path, so that the cable is not stressed when it bends 90° through the inner sidewall.*

5. Pass the cables through the sidewall and connect to the Sash Light Curtain Control Box on the top of the fume hood.
6. Connect the light curtain transmitter and receiver to the Sash Light Curtain Control Box using the plug-in RJ45 cables provided.



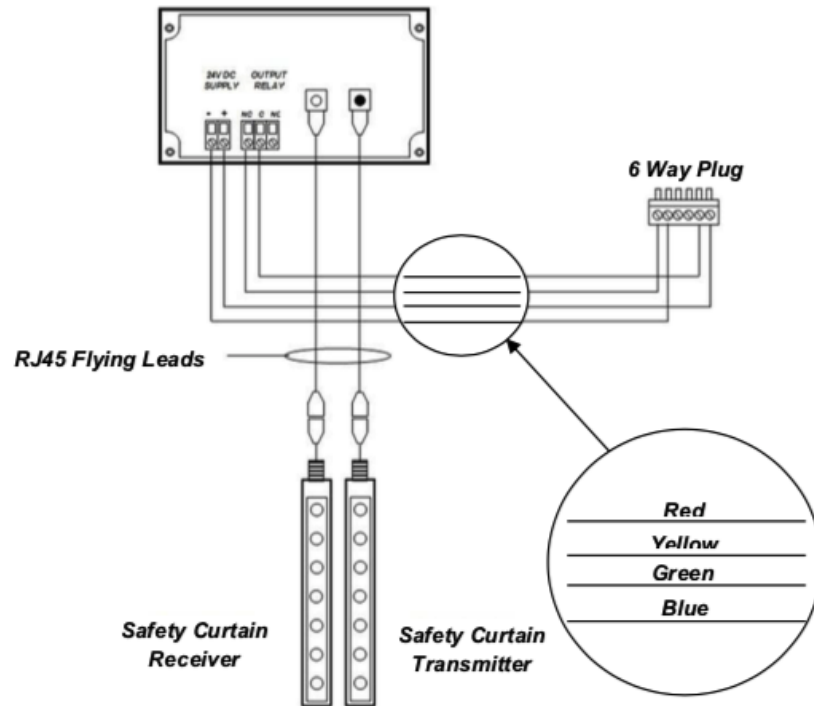

Figure 45: Light Curtain Vertical Range Safety Curtain Transmitter and Receiver Wiring Schematic

7. Use the pre-assembled cables provided to connect the output from the Safety Curtain Control Box to the Auto Sash Control Unit. See the wiring schematic in section 6.9.
8. Fix the light curtain transmitter and receiver to the sidewall using their fixing holes and re-attach the plastic covers.

## 6.4 Installing and aligning the Under Sash sensor

The Under Sash Sensor consists of two components:

- Sash Sensor
- Retro-reflective Tape Strip

1. Fit the sensor so that its lens is clear of obstructions and below the bottom of the sash handle.

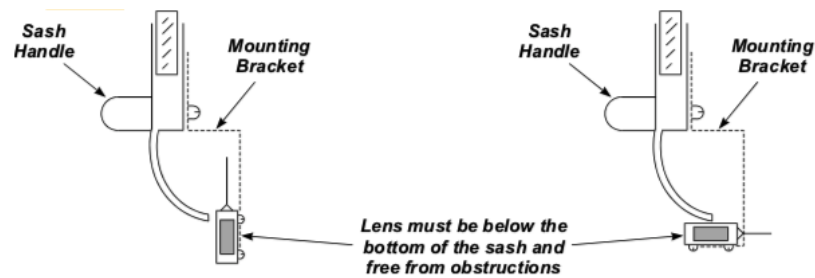

Figure 46: Under sash sensor mounting

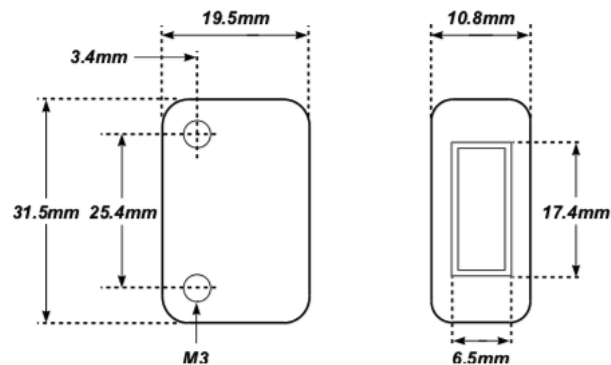

Figure 47: Under sash sensor dimensions

Use a suitable bracket so that the sensor position can be adjusted to the required position.

2. Fix the 5 m cable, which is attached to the sensor, to the sash wire using cable ties. Attach the 5 m cable to the sash counterweight to keep the cable taut as the sash opens or closes.

Encase the cable from the sash counterweight to the sash controller box can in plastic sheathing to guide the cable slack and stop it from snagging.

When it is not possible to fix the cable to the sash wire, use small diameter trunking to attach the cable to the sash.

Use a roller bearing or pulley where the cable runs over a metal surface.

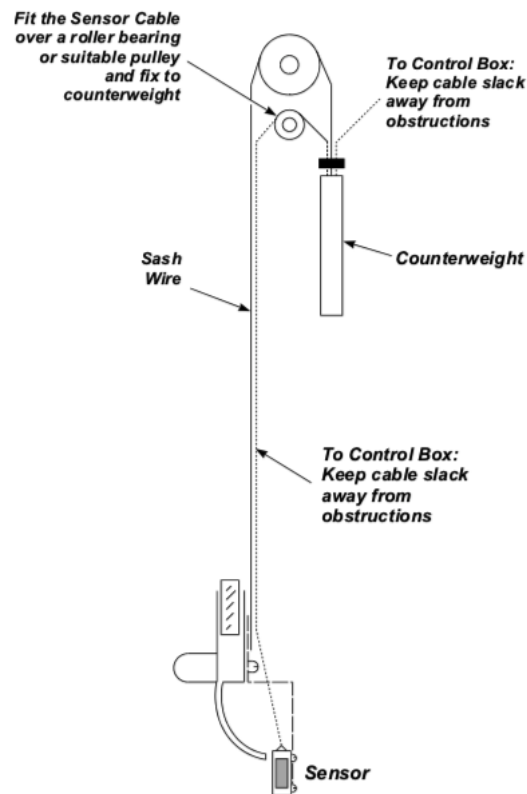

Figure 48: Typical under sash sensor retro-installation

3. Fix the retro-reflective tape strip to the inside of the fume hood, on the opposite side to the sensor.

Position the centre of the retro-reflective tape strip in line with the centre of the sensor. A small offset between the sensor and retro-reflective tape strip is acceptable. The maximum offset values are shown in Figure 49.

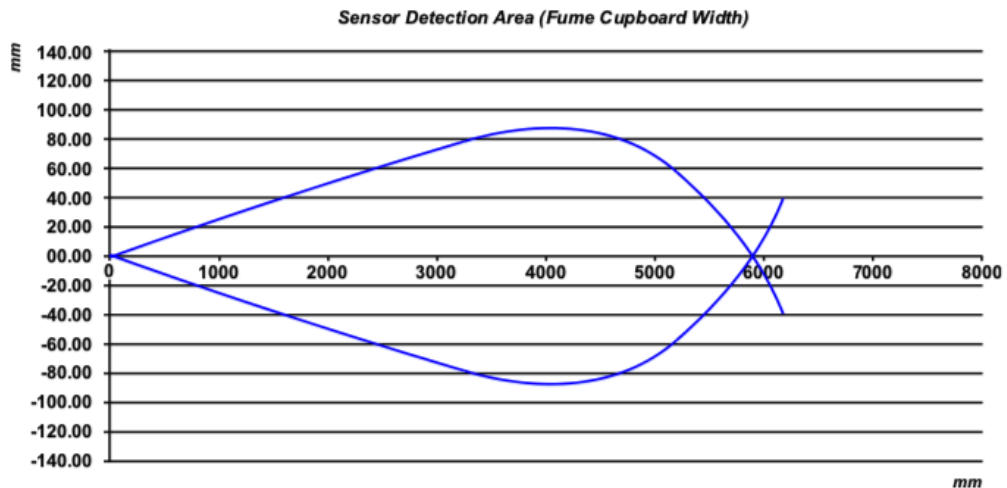

Figure 49: Maximum under sash sensor offset

For example, on a 1000 mm wide Fume Hood the sensor can detect the retro-reflective strip up to  $\pm 20$  mm either side of the Under Sash Sensor's centreline.

4. Connect to the Auto Sash Control Unit. See the wiring schematic in section 6.9.

## 6.5 Tilt switch

Tilt Switches are provided in a variety of forms, the installation instructions that follow are therefore general.

- Ensure that the Tilt Switch is installed in the correct orientation – ‘open’ when the front panel is closed and ‘closed’ when the front panel is open.
- Connect the Tilt Switch to the Auto Sash Control Unit. See the wiring schematic in section 6.9 and Figure 50.
- Link out / connect the relevant terminals on the Auto Sash Control Unit when not using a Tilt Switch. See the wiring schematic in section 6.9 and Figure 50.

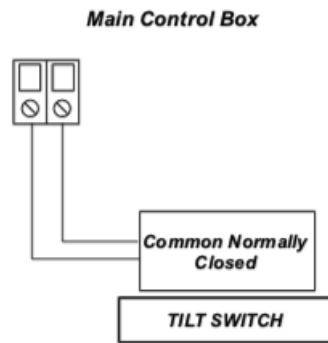

Figure 50: Tilt switch wiring schematic

## 6.6 Sash Low switch

Two types of Sash Low switch can be used:

- Micro-Switch
- Proximity Switch

Switches signal the sash as being open when the switch is open or closed, depending on the installation requirements.

### 6.6.1 Installing the Sash Low micro-switch

The Sash Low Micro-Switch is a change-over type switch. When the sash is closed the switch makes or breaks the circuit depending on which terminals are used on the switch for each type of activation. Typically, the switch would be fitted so that the lever engages (pushes in) when the sash is open.

Connect the Sash Low Micro-Switch to the Auto Sash Control Unit (Figure 51 See the wiring schematic in section 6.9 and Figure 51.

If the switch is installed so that the lever pushes in when the sash is **closed**, connect the wiring to the Auto Sash Control Unit to terminals C and NO on the switch.

If the switch is installed so that the lever pushes in when the sash is **open**, connect the wiring to the Auto Sash Control Unit to terminals C and NC on the switch.

**4 Way Connector  
To Sash Control Box**

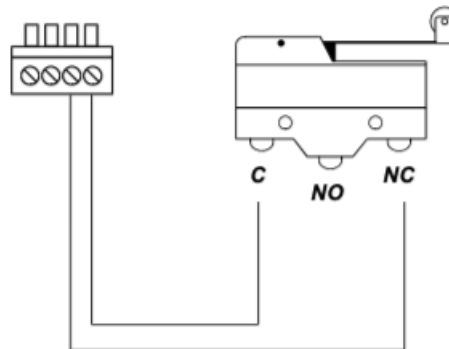

*Figure 51: Sash low micro-switch wiring schematic*

## 6.6.2 *Installing the Sash Low proximity switch*

The Sash Low Proximity Switch is an inductive switch that operates when it comes within range of a metal plate attached to the sash, i.e. when the sash is closed.

The type of switch selected makes or breaks the circuit when the sash is closed. Typically, the switch would be fitted so that the switch is closed when the sash is open.

Connect the Sash Low Proximity Switch to the Auto Sash Control Unit (Figure 52). See the wiring schematic in section 6.9 and Figure 52.

**4 Way Connector  
To Sash Control Box**

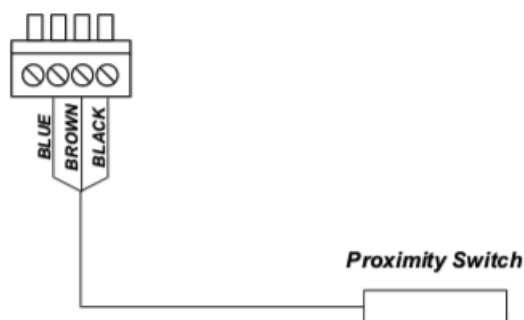

*Figure 52: Sash low proximity switch wiring schedule*

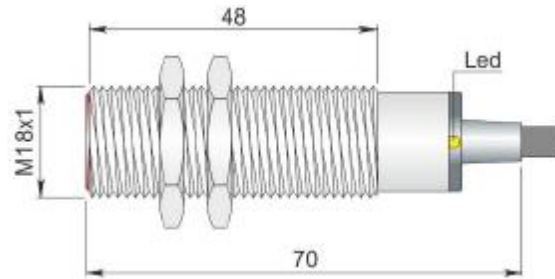

Figure 53: Sash Low Proximity Switch Dimensions

*Note:* When the Auto Sash control is being retro-fitted, fix the bracket to allow for over-travel of the sash.

## 6.7 Sash position sensor

The sash position sensor is fitted with a mounting bracket which can be fitted in four different orientations to enable the sensor draw wire to be correctly aligned.

1. Offer up the sensor to determine the best fixing position on the fume hood framework.

Where possible, ensure the sensor draw wire runs straight out of the sensor housing, in line with the cable housing extension. Where the wire runs at an angle to the sensor, ensure the angle is as small as possible to prevent the wire from rubbing on any part of the sensor body, including the cable housing extension.

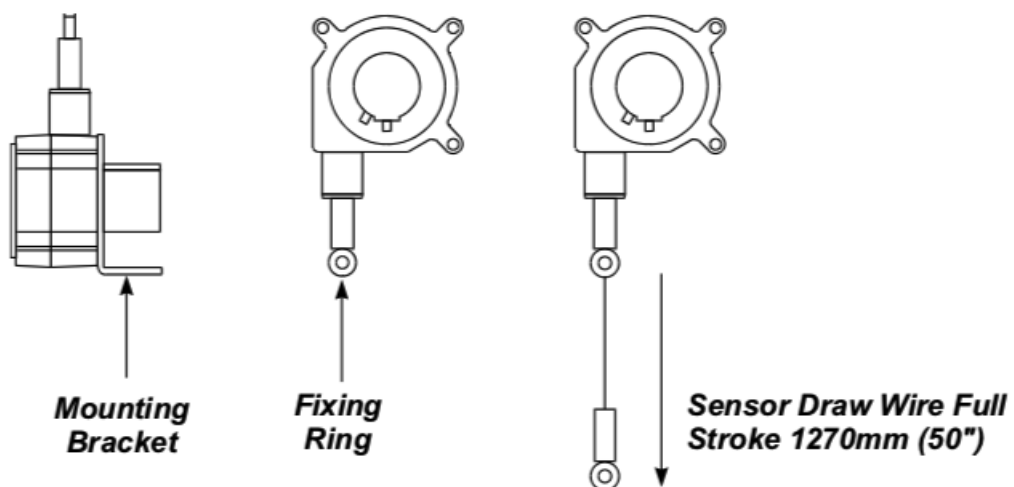

Figure 54: Sash position sensor

2. Mark the fixing holes on the framework and attach the sensor.

The fixing bracket has two 0.37 mm (0.015") diameter fixing holes.

*Note: Ensure that the sensor is in a position that does not over extend the draw wire. The sensor draw wire full stroke is 1270 mm (50") maximum.*

3. Attach the draw wire to either:

- The sash using a suitably sized screw, the draw wire has a 9.53 mm (0.38") diameter fixing ring with a 4.85 mm (0.18") diameter fixing hole in its centre.
- The sash cable using a cable tie, ensuring that the fixing ring does not run over the pulleys.
- The counterweight using a cable (Figure 55).

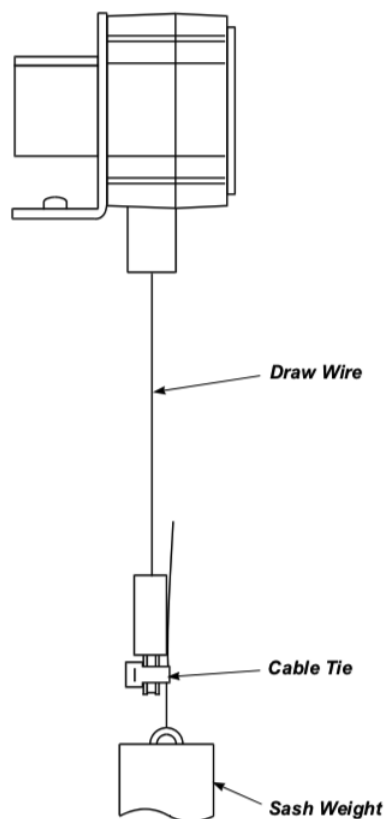

*Figure 55: Sash position sensor draw wire attached by cable tie*

When the sensor is fitted, manually open / close the sash to ensure that the sensor is installed correctly.



## 6.8 Personnel sensor

The Personnel Sensor is supplied as a single transmitter / receiver unit.

### 6.8.1 Installing the personnel sensor

1. Use the mounting template illustrated in Figure 56 and the fixing screws provided to mount the Personnel Sensor. Mount the sensor centrally to the front of the fume hood and above the fume hood sash, use the fixing holes in the back of the sensor.

See the table in Figure 56 for the correct mounting hole dimensions and locations.

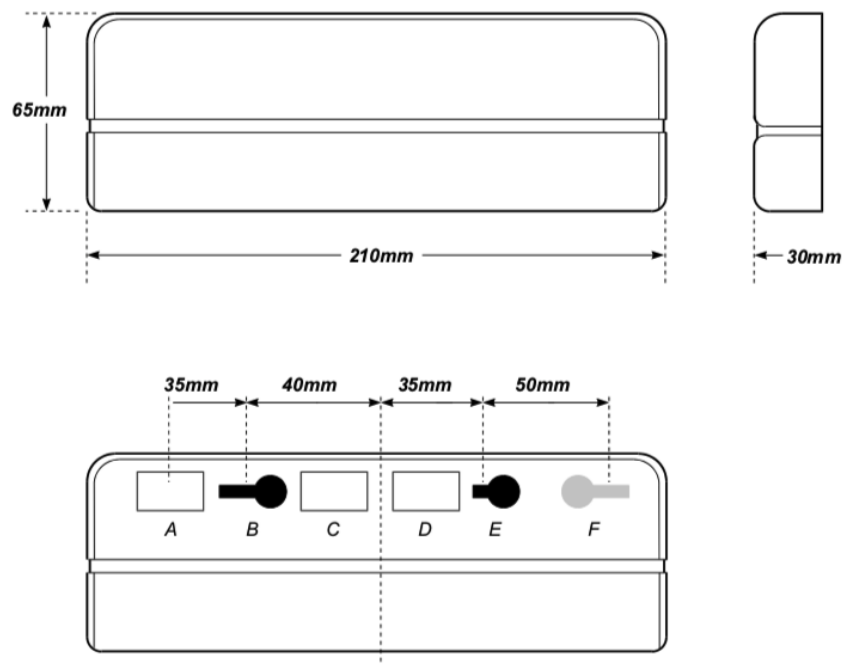

A	Cable Entry	10 x 20 mm (5 mm diameter cable provided)
B	Fixing Hole	5 mm diameter maximum
C	Spare Hole	10 x 20 mm
D	Spare Hole	10 x 20 mm
E	Fixing Hole	5 mm diameter maximum
F	Spare Fixing Hole	5 mm diameter maximum

Figure 56: Personnel sensor mounting details

The Personnel Sensor should be positioned so that it points straight down, with the horizontal axis of the sensor parallel to the horizontal axis of the fume hood (Figure 57).

*Note: Do not mount the sensor higher than 2500mm (98") from the laboratory floor.*

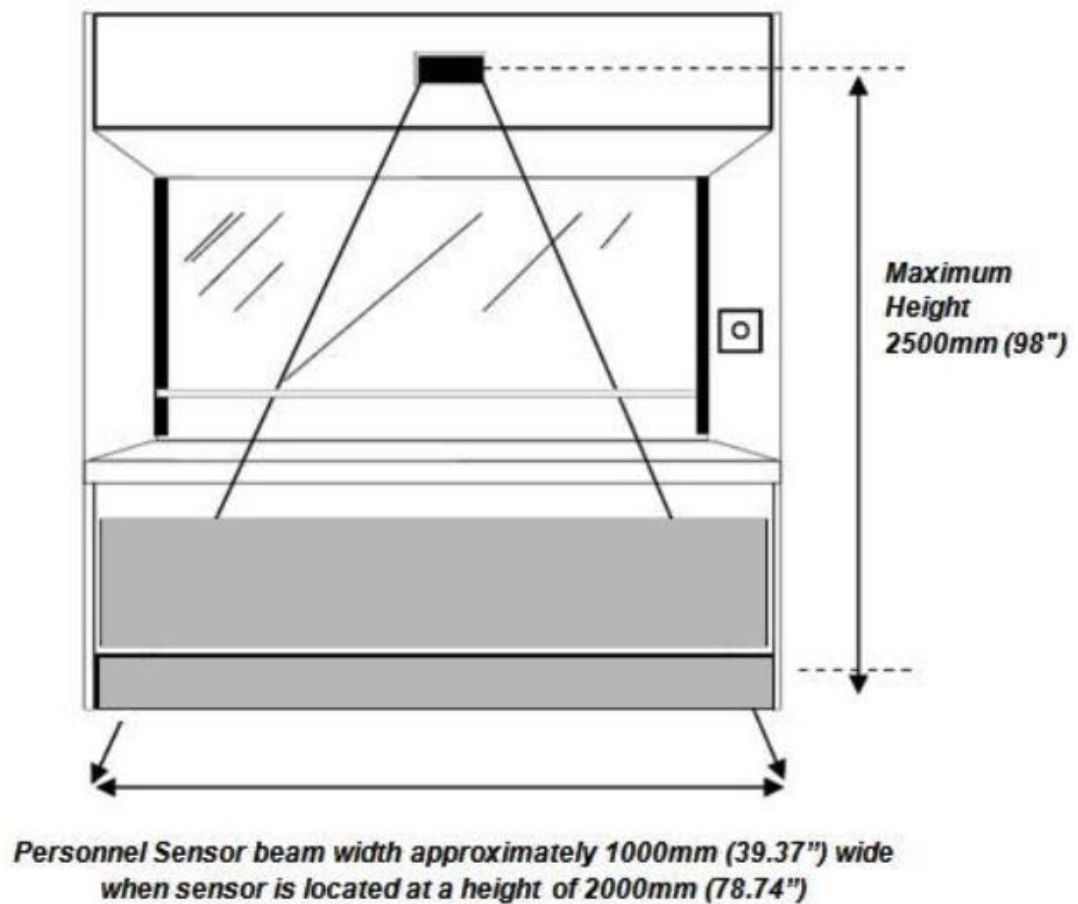

*Figure 57: Vertical positioning of Personnel Sensor*

2. Fit the connection cable to the sensor cable inside the sensor housing.
3. Plug the 4-way terminal block into the Auto Sash Control Unit (Figure 58). See the wiring schematic in section 6.9 and Figure 58.

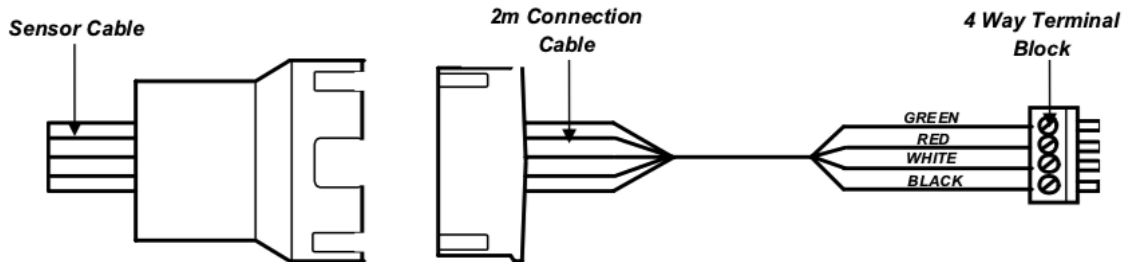

Figure 58: Personnel sensor 4-way terminal block

## 6.8.2 Adjusting the personnel sensor beam width

Adjust the width of the Personnel Sensor's beam to suit different fume hood widths.

To adjust the beam width:

1. Access the two potentiometers under the sensor's front cover (Figure 59).

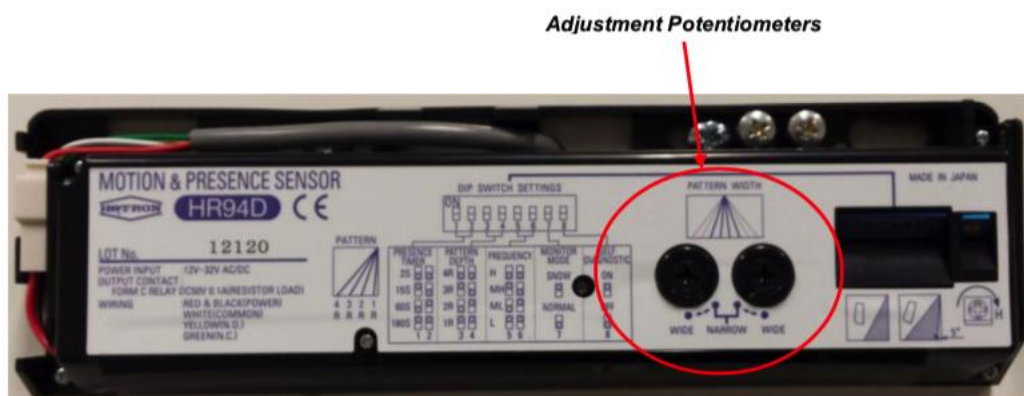

Figure 59: Personnel sensor beam width adjustment potentiometers

2. Adjust the width of the Personnel Sensor beam using the two potentiometers. This is to achieve the best field coverage in front of the fume hood for the hood's width (Figure 60).

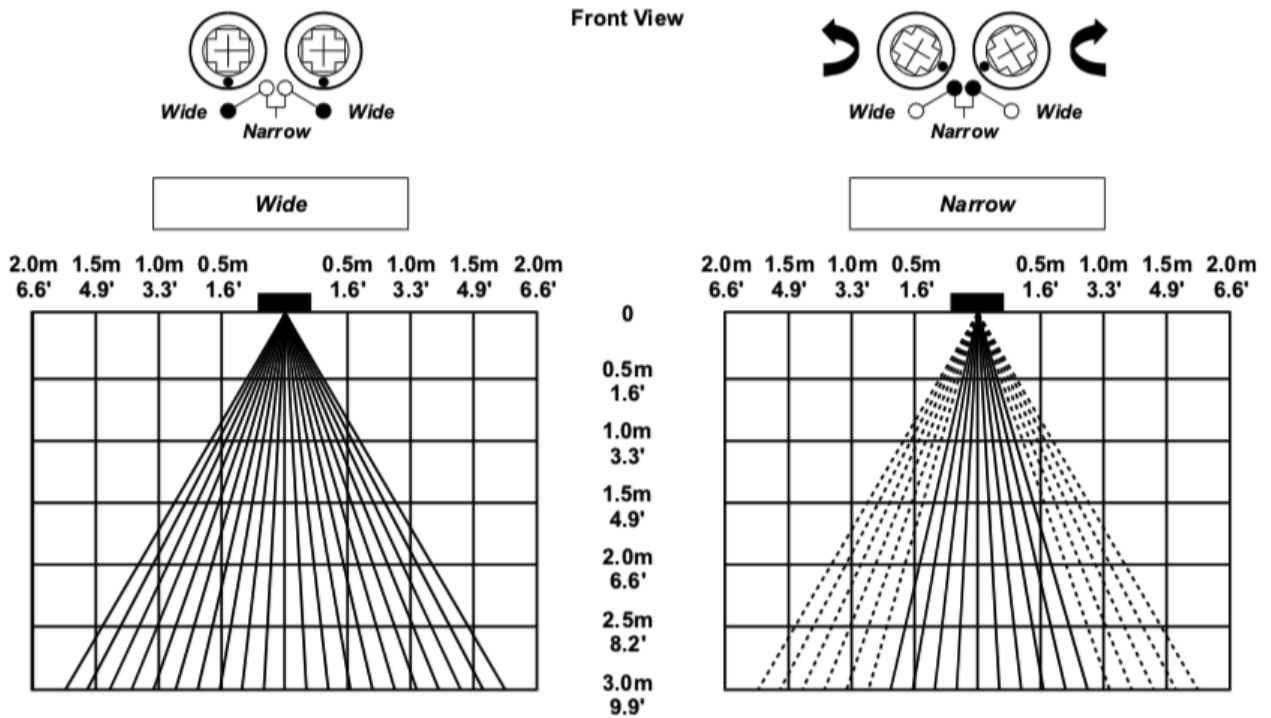

Figure 60: Adjusting personnel sensor beam width

### 6.8.3 Adjusting the beam depth

Adjust the sensor by tilting the bottom of the sensor towards or away from the front wall of the fume hood (Figure 61). This is to ensure that the sensor's beam is at optimum angle from the fume hood, to achieve the best field of coverage for the height of the fume hood.

The body of the Personnel Sensor can be tilted from 0° to 5° in three increments to achieve this.

Side View

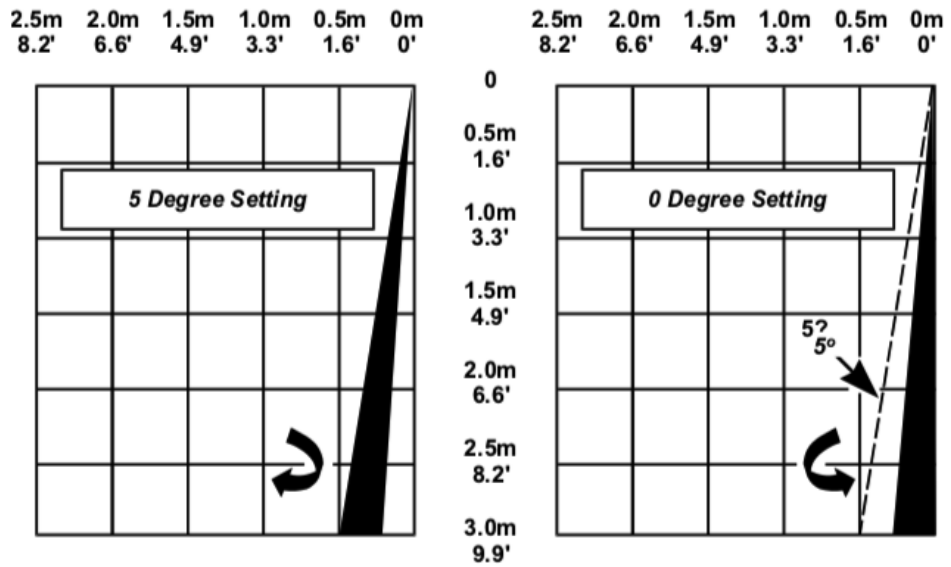

**The body of the sensor can be adjusted from 0° to 5° in 3 steps**

Figure 61: Adjusting the personnel sensor beam angle away from the fume hood

### 6.8.4 Personnel sensor dip switch settings

The following Personnel Sensor functions and parameters are controlled by Dip switches, located within the Sash Light Curtain Control Box (Figure 62) (See section 7.6.10).

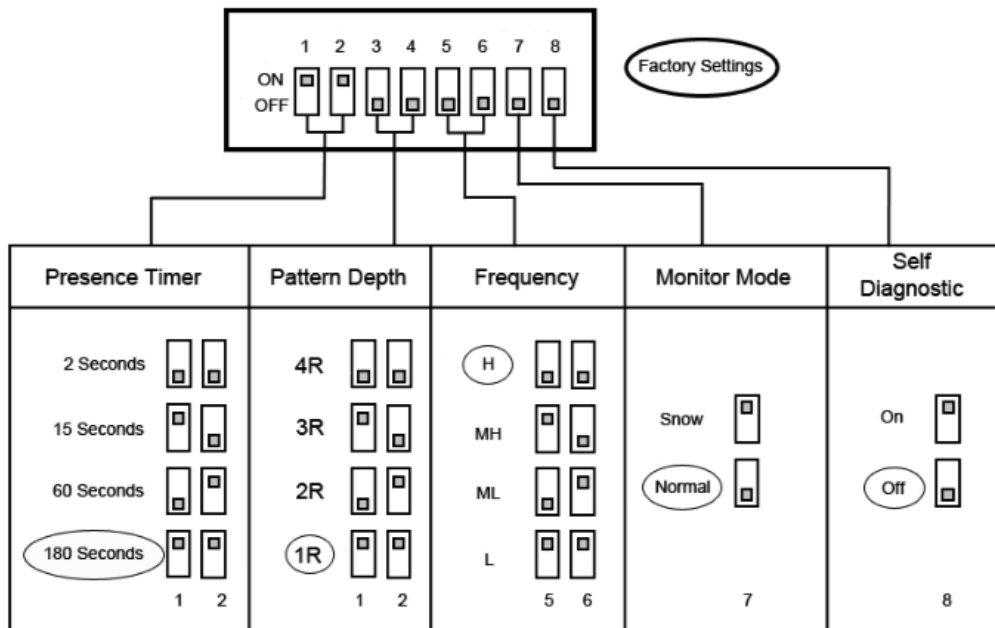
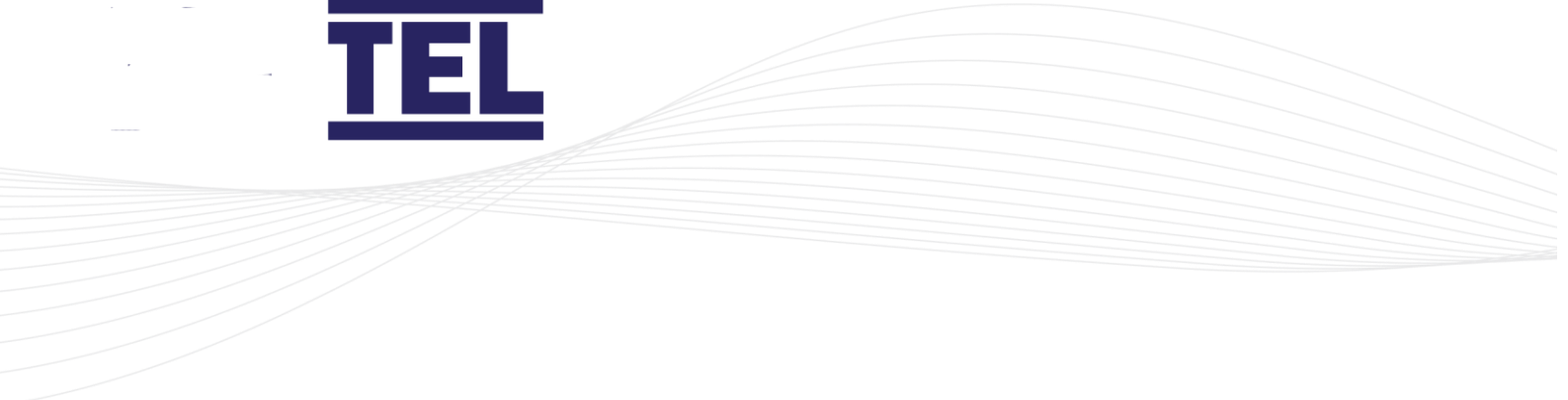

Figure 62: Personnel Sensor Dip Switch Settings

Switches	Setting	Description
1 & 2	Presence timer	Select the time delay before the Personnel Sensor ‘re-learns’ the background when a stationary object is detected.  2, 15, 60 or 180 second delays are selected by setting associated switches 1 and 2 to combinations of ON/OFF (Figure 62).  <i>Note: The timer will reset if any movement is detected during the time period.</i>
3 & 4	Pattern depth	Set the distance of the detection field away from the sensor.

A series of thin, light grey wavy lines that originate from the left side of the page and curve upwards and to the right, creating a decorative background element.

Switches	Setting	Description
5 & 6	Frequency	Select one of four different sensor frequencies (H; MH; M and L) if two or more sensor beam paths overlap.
7	Monitor mode	Select the Monitor Mode. Set the switch to 'Normal'. <i>Note: The 'Snow' setting is only applicable to outdoor applications and therefore is not used.</i>
8	Self-Diagnostics	Setting switch 8 to 'ON' will start a self-diagnostic test when the sensor is switched on. If the test detects a fault the LED will continually flash red and green.





## 6.10 Start up

Make sure the Auto Sash Controller is installed before attempting to calibrate the controller.

When the unit is powered up, the following events occur:

1. The alarm performs a self-test of its functions, LEDs and audible alarm, which takes approximately 3 seconds. All inputs and outputs are deactivated during the self-test.
2. At the end of the delay, the unit will do one of two things:
  - When the controller has been calibrated, the unit enters normal operating mode (Run). The monitor displays the current status or alarm condition.
  - If the Airflow monitor has not been calibrated, the unit displays the messages *Sash drive inhibited*, if the tilt switch input is open, or *Auto Sash Not Configured*, if the tilt switch is closed.

## 7. Calibration

### 7.1 AFA4000/E and AFA4000/E/AS Airflow Monitors

The airflow monitor must be calibrated when it is first installed, or when required during use.

When the unit is powered up, the AFA4000 either enters Run mode (if it has already been calibrated), or it displays the message *Requires set up, press Mute to continue*. The *Set Up* menu allows the unit to be calibrated or configured (password required).

To calibrate the monitor:

1. From the *Run Screen* press and hold the **Mute** button for 5 seconds until the *Main Menu* is displayed.

*Note: When you go from the main menu to the run screen, a note briefly appears saying 'calibration required'.*

2. Use the  $\uparrow$  /  $\downarrow$  buttons to select **Set Up Monitor**, then **Configure**.
3. Enter the password (the factory default password is 0-0-0-0) and press **Mute** to continue.
4. Use the  $\uparrow$  /  $\downarrow$  buttons to select **Econ Configure**, then **Manual/Auto** followed by **Mute**.
5. Select **Manual** and press **Mute** to continue.
6. Open the sash to the normal operating height and use a calibrated instrument to measure the face velocity.
7. Use the  $\uparrow$  /  $\downarrow$  buttons to adjust the manual output so the face velocity is equal to the design velocity (e.g. 0.5 m/sec (100 fpm)). Press **Mute**.
8. Select **Done** followed by **Mute**. This manually sets the output to a fixed value to allow the airflow sensor calibration.
9. Use the  $\uparrow$  /  $\downarrow$  buttons to select **Set Up Monitor**, then **Calibration**.
10. Enter the password (the factory default password is 0-0-0-0) and press **Mute** to continue.

*Note: The Monitor Set up Menu also includes Calibration and Password sub-menus which are used by engineers to set up the system. If you enter any of the Monitor Set up sub-menus by accident, press the  $\uparrow$  and  $\downarrow$  arrows together when the password is requested to return to the Monitor Set up menu.*

11. With the sash open to the normal operating height measure the face velocity using a calibrated anemometer. Use the  $\uparrow$  /  $\downarrow$  buttons to enter the measured face velocity then press **Mute**. The monitor samples the airflow for 5 seconds.

12. If the sample is accepted, lower the sash by half and measure the face velocity using a calibrated instrument. Use the ↑ / ↓ buttons to enter the measured face velocity and press **Mute**. The monitor samples the airflow for 5 seconds.
13. If the calibration is successful, the monitor returns to the *Main Menu*. Select **Run** to go to normal operating mode and check the velocity reading is accurate and stable.
14. If the calibration is stable and accurate, press and hold the **Mute** button for 5 seconds until the *Main Menu* is displayed.
15. Use the ↑ / ↓ buttons to select **Set Up Monitor**, then **Configure**.
16. Enter the password (the factory default password is 0-0-0-0) and press **Mute** to continue.
17. Use the ↑ / ↓ buttons to select **Econ Configure**, then **Manual/Auto** followed by **Mute**.
18. Select **Auto** and press **Mute** to continue.
19. Select **Done** and press **Mute**.
20. Select **Run** to go to normal operating mode.

### 7.1.1 Possible messages

Message	Reason	Actions
Deviations too high	Airflow sample is unstable.	Follow the instructions to repeat the sample or quit the calibration.
Increase higher airflow sample	Second sample value is too close to the first sample value.	Close the sash slightly and repeat the higher sample. The minimum difference between the samples that the controller will accept is 0.3 m/sec (60 fpm).
Sensor diff too low	The monitor does not detect any difference in the sensor output between the 2 airflow samples.	Check that the sensor hose is connected and repeat the calibration.

### 7.1.2 Calibration notes

- Make sure the sensor hose is connected correctly at the side wall and rear of the sensor.
- Make sure the extraction fan is running and the fume cupboard is balanced before calibrating the monitor.

- Take extra time, at least 15 to 20 seconds, to wait for the airflow to settle before capturing the airflow samples. This will minimize the chance of a calibration error due to turbulence or fluctuations.
- Avoid movement in front of the fume cupboard whilst calibrating the monitor.
- The Low and High air samples must be at least 0.3 m/sec (60 fpm) apart to calibrate the monitor. This is to avoid inaccuracy in the calibration due to insufficient difference between the samples. The minimum difference can be changed in the Low High diff parameter in the Cal Config menu.
- Do not use fully open and fully closed sash positions for the calibration points, the recommended positions are normal operating height (e.g. 500 mm, 20") for the first sample and approximately half the sash opening (e.g. 250 mm, 10") for the second sample.
- For the Low Air sample, open the sash to the max safe working opening when using a fume cupboard with sliding sashes.
- For the Higher Air sample, close the sash to approximately 50% of the opening used for the Lower Air sample. The sensor will detect if the Higher Air sample value is too close to the Lower Air sample, and you will be asked to repeat the reading with a higher value. To do this, close the sash slightly and repeat the sample. Do not close the sash below 150 mm.
- The face velocity readings on the open sash may vary at different points on the measuring grid by up to 0.1 m/sec. This is acceptable, long as individual points are not below the designated Low Air alarm point.
- The figure entered for the calibration point can be taken as the average value of all the measuring grid readings or could be taken as the individual lowest point on the grid. This low point is typically located in the centre of the bottom row. The low point is a suitable convenient position to measure and for alarm testing.
- When calibrating the alarm, it is important to ensure that the 'Vent kit' is connected to the SM7 sensor on the fume cupboard. When the vent kit is not connected to the sensor, the sensor will not detect a change in the airflow during the calibration procedure and will display *Sensor Difference too low - Check sensor*. This only applies during calibration.
- When the vent kit becomes disconnected following calibration the air flow across the sensor will fall and the alarm will go into the 'Air Fail' condition.
- When calibrating the Controller for Dual Set point operation, bear in mind the accuracy at both set points. The Low Air sample should be taken at the approximate Low set point value (e.g. 0.3 m/sec) and the High Air sample should be taken at the approximate High Air set point value (e.g. 0.6 m/sec) considering the min 0.3 m/sec difference required between the calibration values.

If the airflow display is unstable following the calibration because of environmental turbulence or sensor position and cannot be rectified, then it is possible to adjust the sensitivity of the displayed value using the Display Smoothing parameter in the Cal Config menu. The controller displays the velocity value as a rolling average over time and is adjustable over 1 to 100 seconds.

*Note* The control output is not affected by the display smoothing so will provide fast response control based on the sensor output. If the control output is unstable due to turbulence on the sensor, then the output can be tuned to give stable control in the Econ Config menu (see section 8.2).

## 7.2 Auto Sash Controller 1, 2 or 3 position.

This section describes the calibration of the Auto Sash Controller from the AFA4000/E/AS.

*Note:* Refer to section 7.6 to calibrate the Auto Sash Controller from the Auto Sash keypad

1. From the *Run Screen* press and hold the **Mute** button for 5 seconds until the *Main Menu* is displayed.
2. Use the  $\uparrow$  /  $\downarrow$  buttons to select **Set Up Auto Sash**. The display shows the message *TEL SASH CLOSER*.
3. Press the **Mute** button to display the current Hardware and Software version, for example, *1. HW2.0 FW1.1*.
4. Press the  $\downarrow$  button to scroll down and select **Setup Menu** and press **Mute**.
5. Enter the password (the factory default password is 1-0-0-1) and press **Mute** to continue.
6. In the Setup menu the controller displays *System Profile*.
7. Use the  $\downarrow$  button to scroll through the menu, select **Sash Settings** and press **Mute**.
8. In the *Autosash configuration menu*, the display will show *1. Enabled*.
9. Use the  $\downarrow$  button to scroll through the menu and select *4. Calibration* and press **Mute**.
10. Follow the on-screen instructions and set the sash to the centre opening, for example, 250 mm.
11. Press the  $\downarrow$  button to find which arrow represents the sash closing and press **Mute**. This step shows the controller which direction the motor needs to drive to close the sash.
12. Close the sash and press **Mute**. This step sets the sash position sensor output, 0 V position.
13. Fully open the sash and press **Mute**. This step sets the sash position sensor output, 10 V position.
14. Set the sash to the lower position, for example, close and press **Mute**.

15. Set the positions as required:

- |                           |   |
|---------------------------|---|
| For 1 position operation: | When only the lower position is required (for example, close only), press ↑ / ↓ together to quit.   |
| For 2 position operation: | Set the sash to the normal working height (for example, 500 mm) and press <b>Mute</b> .<br>Press ↑ / ↓ together to quit, when only 2 positions (lower and middle) are required.                 |
| For 3 position operation: | Set the sash to the full opening height (for example, 750 mm) and press <b>Mute</b> .<br>The lower, middle and top positions are now calibrated.<br>Press <b>Mute</b> to quit calibration mode. |

16. Use the ↓ button and select **Back to Set up menu**, then press **Mute**.

17. Use the ↓ button and select **Exit and Save Changes**, then press **Mute**.

18. The controller now enters *Run* mode.

### 7.2.1 Calibration notes

The sash may slightly over-run past the calibration points, when the sash motor drive is set to a fast speed. When calibrating the sash positions, allow a margin for the sash to over-travel past the calibration height.

For example, before calibrating the lower position, fully close the sash and then open it by 5 mm, or before calibrating the middle position, open the sash to the normal height and then lower it by 5 mm.

### 7.2.2 DDA Calibration

This section describes the calibration of the Auto Sash Controller from the AFA4000/E/AS.

*Note: Refer to section 7.6 to calibrate the Auto Sash Controller from the Auto Sash keypad*

1. From the *Run Screen* press and hold the **Mute** button for 5 seconds until the *Main Menu* is displayed.
2. Use the ↑ / ↓ buttons to select **Set Up Auto Sash**. The display shows the message *TEL SASH CLOSER*.
3. Press the **Mute** button to display the current Hardware and Software version, for example, *1. HW2.0 FW1.1*.
4. Press the ↓ button to scroll down and select **Setup Menu** and press **Mute**.

5. Enter the password (the factory default password is 1-0-0-1) and press **Mute** to continue.
6. In the Setup menu the controller displays *System Profile*.
7. Press the **Mute** button and use the ↑ / ↓ buttons to select **DDA** profile and press **Mute**.
8. Use the ↓ button to scroll through the menu, select **Sash Settings** and press **Mute**.
9. In the *Autosash configuration menu*, the display will show *1. Enabled*.
10. Use the ↓ button to scroll through the menu and select *4. Calibration* and press **Mute**.
11. Follow the on-screen instructions and set the sash to the centre opening, for example, 250 mm.
12. Press the ↓ button to find which arrow represents the sash closing and press **Mute**. This step shows the controller which direction the motor needs to drive to close the sash.
13. Fully lower the Base and Fully close the sash and press **Mute**.
14. Fully raise the Base and Fully close the sash and press **Mute**.
15. Fully open the sash and press **Mute**.
16. With the Base Fully raised close the sash and set the bottom position and press **Mute**.
17. Set the positions as required:

For 1 position operation:	When only the lower position is required (for example, close only), press ↑ / ↓ together to quit.
For 2 position operation:	Set the sash to the normal working height (for example, 500 mm) and press <b>Mute</b> . Press ↑ / ↓ together to quit, when only 2 positions (lower and middle) are required.
For 3 position operation:	Set the sash to the full opening height (for example, 750 mm) and press <b>Mute</b> . The lower, middle and top positions are now calibrated. Press <b>Mute</b> to quit calibration mode.
18. Use the ↓ button and select **Back to Set up menu**, then press **Mute**.
19. Use the ↓ button and select **Exit and Save Changes**, then press **Mute**.
20. The controller now enters *Run* mode.

Note, the Auto Lock, Auto Stop, Auto Open and Overcurrent Monitor functions also operate in the DDA profile.

## 7.3 Sash lock function

This section describes the calibration of the Auto Sash Controller from the AFA4000/E/AS.

*Note: Refer to section 7.6 to calibrate the Auto Sash Controller from the Auto Sash keypad*

1. From the *Run Screen* press and hold the **Mute** button for 5 seconds until the *Main Menu* is displayed.

*Note: When you go from the main menu to the run screen, a note briefly appears saying 'calibration required'.*

2. Use the ↑ / ↓ buttons to select **Set Up Auto Sash**. The display shows the message *TEL SASH CLOSER*.
3. Press the **Mute** button to display the current Hardware and Software version, for example, *1. HW2.0 FW1.1*.
4. Press the ↓ button to scroll down and select **Setup Menu** and press **Mute**.
5. Enter the password (the factory default password is 1-0-0-1) and press **Mute**.
6. In the *Configuration* menu the controller will display the message *System Profile*.
7. Use the ↓ button to scroll through the menu and select **Sash Settings**, then press **Mute**.
8. In the *Configuration menu* the display will show *1. Enabled*.
9. Use the ↓ button to scroll through the menu and select **8. Auto Lock**. Press **Mute**.
10. Set to **Enabled** and press **Mute**.
11. Use the ↓ button to scroll through the menu and select **Lock Alarm**. Press **Mute**.
12. Use the ↑ / ↓ buttons to set the required alarm delay time. Press **Mute**.
13. Use the ↓ button to scroll through the menu and select **Lock Pos Calibration**. Press **Mute**.
14. The display will show on-screen instructions.
15. Open the sash to the Lock position and press **Mute**.

When the selected position is too low, for example, it is lower than the calibrated Lower, Middle or Top positions, the message *Bad position - try again* displays.

If the chosen position is OK, the lock position will be set.

16. Use the ↓ button and select **Back** then **Back to Set up menu**. Press **Mute**.
17. Use the ↓ button and select **Exit and Save Changes**. Press **Mute**.

The controller returns to the Main Menu. Either select **Run**, or wait a few seconds for it to automatically enter Run mode.



## 7.4 Over Current Monitor

1. From the *Run Screen* press and hold the **Mute** button for 5 seconds until the *Main Menu* is displayed.
  2. Use the ↑ / ↓ buttons to select **Set Up Auto Sash**. The display shows the message *TEL SASH CLOSER*.
  3. Press the **Mute** button to display the current Hardware and Software version, for example, *1. HW2.0 FW1.1*.
  4. Press the ↓ button to scroll down and select **Setup Menu** and press **Mute**.
  5. Enter the password (the factory default password is 1-0-0-1) and press **Mute**.
  6. In the *Configuration* menu the controller will display the message *System Profile*.
  7. Use the ↓ button to scroll through the menu and select **Sash Settings**, then press **Mute**.
  8. In the *Configuration menu* the display will show *1. Enabled*.
  9. Use the ↓ button to scroll through the menu and select **3. Motor Drive**. Press **Mute**.
  10. Use the ↓ button to scroll through the menu and select **Motor Current Display**, Press **Mute**.
  11. Use the ↑ / ↓ buttons to select **Max**, Press **Mute**.
- Note: Select **Max** to show the *Peak current* or **Live** to show the *live value*.
12. Use the ↓ button and select **Back** then **Back to Set up menu**. Press **Mute**.
  13. Use the ↓ button and select **Exit and Save Changes**. Press **Mute**.
  14. When the Motor drives, the selected **Max** or **Live** current will be displayed in the status bar.
  15. Determine the current limit required for either sash open, sash close or both.
  16. From the *Run Screen* press and hold the **Mute** button for 5 seconds until the *Main Menu* is displayed.
  17. Use the ↑ / ↓ buttons to select **Set Up Auto Sash**. The display shows the message *TEL SASH CLOSER*.
  18. Press the ↓ button to scroll down and select **Setup Menu** and press **Mute**.
  19. Enter the password (the factory default password is 1-0-0-1) and press **Mute**.
  20. Use the ↓ button to scroll through the menu and select **Sash Settings**, then press **Mute**.
  21. Use the ↓ button to scroll through the menu and select **3. Motor Drive**. Press **Mute**.
  22. Use the ↓ button to scroll through the menu and select **Motor Current Display**, Press **Mute**.
  23. Use the ↑ / ↓ buttons to select **Off**, Press **Mute**.
  24. Use the ↓ button to scroll through the menu and select **Over current Open**, Press **Mute**.
  25. Use the ↑ / ↓ buttons to set the required limit, Press **Mute**.
  26. Use the ↓ button to scroll through the menu and select **Over current Close**, Press **Mute**.
  27. Use the ↑ / ↓ buttons to set the required limit, Press **Mute**

Note: If a limit is not required set to the max value (300mA)

28. Use the ↓ button and select **Back** then **Back to Set up menu**. Press **Mute**.

29. Use the ↓ button and select **Exit and Save Changes**. Press **Mute**.

The controller returns to the Main Menu. Either select **Run**, or wait a few seconds for it to automatically enter Run mode.

## 7.5 Auto Stop

1. From the *Run Screen* press and hold the **Mute** button for 5 seconds until the *Main Menu* is displayed.
2. Use the ↑ / ↓ buttons to select **Set Up Auto Sash**. The display shows the message *TEL SASH CLOSER*.
3. Press the **Mute** button to display the current Hardware and Software version, for example, *1. HW2.0 FW1.1*.
4. Press the ↓ button to scroll down and select **Setup Menu** and press **Mute**.
5. Enter the password (the factory default password is 1-0-0-1) and press **Mute**.
6. In the *Configuration* menu the controller will display the message *System Profile*.
7. Use the ↓ button to scroll through the menu and select **Sash Settings**, then press **Mute**.
8. In the *Configuration menu* the display will show *1. Enabled*.
9. Use the ↓ button to scroll through the menu and select **9. Auto Stop**. Press **Mute**.
10. The Auto Stop will be disabled, Press **Mute** then use the ↑ button to select **Enabled**. Press **Mute**.
11. Press the ↓ button to scroll down and select **Auto Stop Distance** and press **Mute**.
12. Use the ↑ / ↓ buttons to set the required Auto stop distance above the normal position, Press **Mute**.
13. Press the ↓ button to scroll down and select **Auto Stop Delay** and press **Mute**.
14. Use the ↑ / ↓ buttons to set the required Delay time before the sash returns to the normal position after it has Auto stopped, Press **Mute**.
15. Use the ↓ button and select **Back** then **Back to Set up menu**. Press **Mute**.
16. Use the ↓ button and select **Exit and Save Changes**. Press **Mute**.

The controller returns to the Main Menu. Either select **Run**, or wait a few seconds for it to automatically enter Run mode.

## 7.6 *Auto Sash Controller – stand-alone*

This section refers to when the Auto Sash Controller is used without the AF4000/E/AS Airflow Monitor.

Before starting up the Auto Sash Controller, ensure that all Auto Sash Control System components have been correctly installed and connected.

*Note: Check that the fume hood sash and associated motor drives, pulleys, operating cables, racks and chains move freely over their entire operating ranges.*

*Note: Check that all cables are secured away from moving components and are not overstressed or damaged.*

*Note: Check the security of all electrical connections.*

### 7.6.1 *Starting up the Auto Sash Control Unit*

1. Switch on the Auto Sash Control Unit.

When powering up, the Auto Sash Control Unit performs a self-test of its functions, LEDs and the audible alarm. This self-test takes approximately 3 seconds.

During the self-test period, all inputs and outputs are de-activated.

2. At the end of the self-test, the Auto Sash Control Unit will do one of two things:

If the Auto Sash Control Unit has previously been calibrated:

- The Auto Sash Controller enters the Normal Operating Mode and displays its current status or alarm condition.

If the Auto Sash Control Unit has not been calibrated:

- When the Tilt Switch input is open, the display shows 'Sash Drive Inhibited'.
- When the Tilt Switch input is closed, the display shows 'Auto Sash Not Configured'.

### 7.6.2 *Calibrating the Auto Sash Control Unit for Tiptronic operation using the Auto Sash keypad*

The Auto Sash Control Unit must have each of its required stationary positions defined for Tiptronic functionality:

1. Press and hold the **Enter** button for approximately 5 seconds or until the main menu appears.

The LCD display will show the current hardware and software versions. For example, *1. HW2.0 FW1.1.*

2. Press ↓ and select *2. Setup.*
3. Press **Enter**.
4. Enter the Password using the ↑ arrow and **Enter** button, the factory default is 1 0 0 1. In the Set-Up menu, the controller will display *Keypad Tones.*
5. Press ↓ and select *Sash Settings.*
6. Press **Enter**.

In the S1 (Sash 1) Settings menu, the display will show *1. Enabled.*

7. Press ↓ and select *4. Calibration.*
8. Press **Enter**.

The display will show on screen instructions. For example:

"Manually move sash to centre and then press the Up/Down keys to find sash down direction. Press Cancel to abort Calibration"

9. Move the sash to the middle of the sash opening.
10. Press ↑/↓ buttons to determine which arrow activates sash closing.
11. Press the ↑/↓ button which closes the sash, press **Enter**.

This instructs the controller which direction the motor needs to turn to close the sash.

12. Move the sash to the lowest position required, press **Enter**.
13. Either:

- Press **Mute**, if this is the only pre-set position required, or
- Set the sash to the normal working height, for example 500 mm.

14. Press **Enter**, for two position operation.

15. Either:

- Press **Mute**, if only two pre-set positions ('lowest' and 'normal') are required.
- Set the sash to the full opening height.

16. Press **Enter**, for three position operation.

The lowest, normal and fully open positions are now calibrated.

17. Press **Enter**, to exit Calibration mode.
18. Press ↓ button, select *Back to Set up* menu.
19. Press **Enter**.
20. Press ↓ button, select *Exit and Save Changes.*
21. Press **Enter**.

The Controller will now enter *Run* mode.

*Note: When the Auto Sash motor drive is set to a high speed, allow a margin for the sash to over-run when calibrating the sash position. See the instructions above. Allow a 5 mm (0.197") margin at the highest and lowest point.*

### 7.6.3 DDA Calibration

1. Press and hold the **Enter** button for approximately 5 seconds or until the main menu appears.  
The LCD display will show the current hardware and software versions. For example, *1. HW2.0 FW1.1.*
2. Press ↓ and select *2. Setup.*
3. Press **Enter**.
4. Enter the Password using the ↑ arrow and **Enter** button, the factory default is 1 0 0 1. In the Set-Up menu, the controller will display *Keypad Tones.*
5. Press ↓ and select *System Profile.*
6. Press the **Enter** button and use the ↑ / ↓ buttons to select **DDA** profile and press **Enter**.
7. Use the ↓ button to scroll through the menu, select **Sash Settings** and press **Enter**.
8. In the *Autosash configuration menu*, the display will show *1. Enabled.*
9. Use the ↓ button to scroll through the menu and select *4. Calibration* and press **Enter**.
10. Follow the on-screen instructions and set the sash to the centre opening, for example, 250 mm.
11. Press the ↓ button to find which arrow represents the sash closing and press **Enter**. This step shows the controller which direction the motor needs to drive to close the sash.
12. Fully lower the Base and Fully close the sash and press **Enter**.
13. Fully raise the Base and Fully close the sash and press **Enter**.
14. Fully open the sash and press **Enter**.
15. With the Base Fully raised close the sash and set the bottom position and press **Enter**.
16. Set the positions as required:

For 1 position operation:	When only the lower position is required (for example, close only), press ↑ / ↓ together to quit.
For 2 position operation:	Set the sash to the normal working height (for example, 500 mm) and press <b>Enter</b> . Press ↑ / ↓ together to quit, when only 2 positions (lower and middle) are required.
For 3 position operation:	Set the sash to the full opening height (for example, 750 mm) and press <b>Enter</b> .

The lower, middle and top positions are now calibrated.  
Press **Enter** to quit calibration mode.

17. Press **Enter**, to exit Calibration mode.
18. Press ↓ button, select *Back to Set up* menu.
19. Press **Enter**.
20. Press ↓ button, select *Exit and Save Changes*.
21. Press **Enter**.

The Controller will now enter *Run* mode.

Note, the Auto Lock, Auto Stop, Auto Open and Overcurrent Monitor functions also operate in the DDA profile.

#### 7.6.4 *Calibrating the sash lock function*

To define the required Sash Lock position:

1. Press and hold the **Enter** button for 5 seconds until the *Main Menu* is displayed.
2. The current Hardware and Software versions are displayed, for example *1. HW2.0 FW1.1*
3. Press ↓ button, select *2. Setup* and press **Enter**.
4. Enter the Password using the ↑ button and **Enter** button, the factory default is 1 0 0 1. In the Set-Up menu, the controller will display *Keypad Tones*.
5. Press ↓ button, select *Sash Settings* and press **Enter**. The controller will display *1. S1 Enabled*.
6. Press ↓ button, select *8. Auto Lock* and press **Enter**.
7. Set to *Enabled* and press **Enter**.
8. Use the ↓ button to scroll through the menu and select **Lock Alarm**. Press **Enter**.
9. Press ↑/↓ buttons to set the required alarm delay time and press **Enter**.
10. P Use the ↓ button to scroll through the menu and select **Lock Pos Calibration**. Press **Enter**.
11. Instructions will be displayed, for example: Lock the sash then move the sash to the lowest lock position. Enter to accept. Cancel to abort
12. Open the sash to the Lock position and press **Enter**.

If the position chosen is too low, lower than the calibrated Bottom, Middle or Top positions, *Bad position - try again* will be displayed.

If the chosen position is acceptable, the lock position will be set.

13. Press ↓ button, select *Back to Set up menu* and press **Enter**.
14. Press ↓ button, select *Exit and Save Changes* and press **Enter**.

The Auto Sash Controller will now go to *RUN* mode.

### 7.6.5 Over Current Monitor

1. Press and hold the **Enter** button for 5 seconds until the *Main Menu* is displayed.
2. The current Hardware and Software versions are displayed, for example *1. HW2.0 FW1.1*
3. Press ↓ button, select **2. Setup** and press **Enter**.
4. Enter the Password using the ↑ button and **Enter** button, the factory default is 1 0 0 1. In the Set-Up menu, the controller will display *Keypad Tones*.
5. Press ↓ button, select *Sash Settings* and press **Enter**. The controller will display *1. S1 Enabled*.
6. Use the ↓ button to scroll through the menu and select **3. Motor Drive**. Press **Enter**.
7. Use the ↓ button to scroll through the menu and select **Motor Current Display**, Press **Enter**.
8. Use the ↑ / ↓ buttons to select **Max**, Press **Enter**.

Note: *Select Max to show the Peak current or Live to show the live value.*

9. Use the ↓ button and select **Back** then **Back to Set up menu**. Press **Enter**.
10. Use the ↓ button and select **Exit and Save Changes**. Press **Enter**.
11. When the Motor drives, the selected **Max** or **Live** current will be displayed in the status bar.
12. Determine the current limit required for either sash open, sash close or both.
13. From the *Run Screen* press and hold the **Enter** button for 5 seconds until the *Main Menu* is displayed.
14. Use the ↑ / ↓ buttons to select **Set Up Auto Sash**. The display shows the message *TEL SASH CLOSER*.
15. Press the ↓ button to scroll down and select **Setup Menu** and press **Enter**.
16. Enter the password (the factory default password is 1-0-0-1) and press **Enter**.
17. Use the ↓ button to scroll through the menu and select **Sash Settings**, then press **Enter**
18. Use the ↓ button to scroll through the menu and select **3. Motor Drive**. Press **Enter**.
19. Use the ↓ button to scroll through the menu and select **Motor Current Display**, Press **Enter**.
20. Use the ↑ / ↓ buttons to select **Off**, Press **Enter**.
21. Use the ↓ button to scroll through the menu and select **Over current Open**, Press **Enter**.
22. Use the ↑ / ↓ buttons to set the required limit, Press **Enter**.
23. Use the ↓ button to scroll through the menu and select **Over current Close**, Press **Enter**.
24. Use the ↑ / ↓ buttons to set the required limit, Press **Enter**.

Note: *If a limit is not required set to the max value (300mA)*

25. Use the ↓ button and select **Back** then **Back to Set up menu**. Press **Enter**.



26. Use the ↓ button and select **Exit and Save Changes**. Press **Enter**.  
The Auto Sash Controller will now go to *RUN* mode.

### 7.6.6 *Setting the Auto Stop Function*

1. Press and hold the **Enter** button for 5 seconds until the *Main Menu* is displayed.
2. The current Hardware and Software versions are displayed, for example *1. HW2.0 FW1.1*
3. Press ↓ button, select **2. Setup** and press **Enter**.
4. Enter the Password using the ↑ button and **Enter** button, the factory default is 1 0 0 1. In the Set-Up menu, the controller will display *Keypad Tones*.
5. Press ↓ button, select *Sash Settings* and press **Enter**. The controller will display *1. S1 Enabled*.
6. Use the ↓ button to scroll through the menu and select **9. Auto Stop**. Press **Enter**.
7. The Auto Stop will be disabled, Press **Enter** then use the ↑ button to select Enabled. Press **Enter**.
8. Press the ↓ button to scroll down and select Auto Stop Distance and press **Enter**.
9. Use the ↑ / ↓ buttons to set the required Auto stop distance above the normal position, Press **Enter**.
10. Press the ↓ button to scroll down and select Auto Stop Delay and press **Enter**.
11. Use the ↑ / ↓ buttons to set the required Delay time before the sash returns to the normal position after it has Auto stopped, Press **Enter**.
12. Use the ↓ button and select **Back** then **Back to Set up menu**. Press **Enter**.
13. Use the ↓ button and select **Exit and Save Changes**. Press **Enter**.  
The Auto Sash Controller will now go to *RUN* mode.



### 7.6.7 *Calibrating the safety light curtain*

To adjust the range and sensitivity of the Safety Light Curtain:

1. Ensure the area between the Safety Light Curtain transmitter and receiver is free from obstructions.
2. Ensure the light beam paths are not broken and the Personnel Sensor is disabled so that the sash does not Auto-Close whilst the Safety Light Curtain is being calibrated.

*Note: If it is not possible to disable the Personnel Sensor, remove the motor / clutch connector from the Auto Sash Control Unit. This activates the Sash Control Alarm after the selected time delay and the reset button must be pressed once the Safety Light Curtain has been calibrated.*

3. Remove the cover from the Safety Light Curtain Control Box.

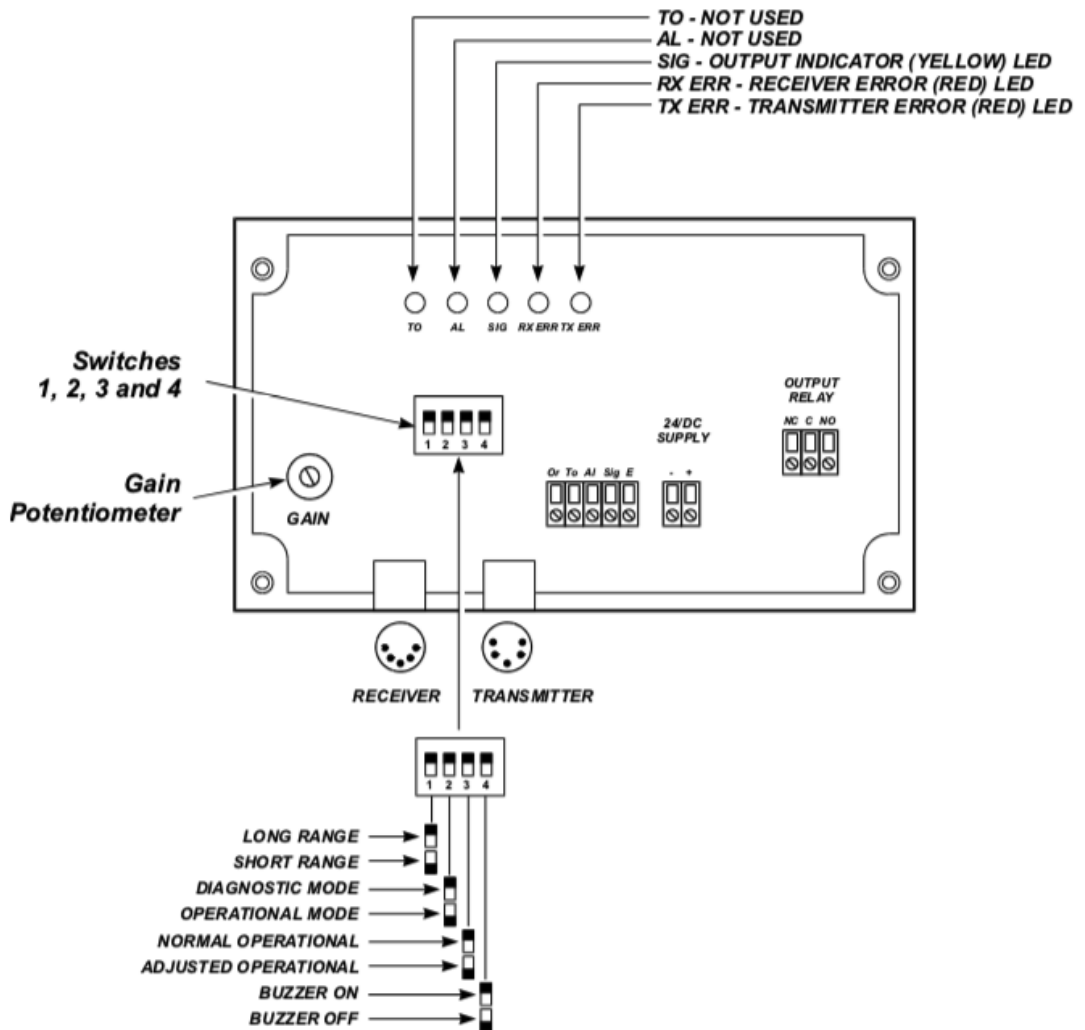

Figure 63: Safety Light Curtain Control Box with lid removed

4. Power up the Auto Sash Control Unit.
5. Check that the Safety Light Curtain Transmitter and Receiver are connected correctly and are operational.

The red *Power On* LED will now be visible on the receiver (Figure 64).

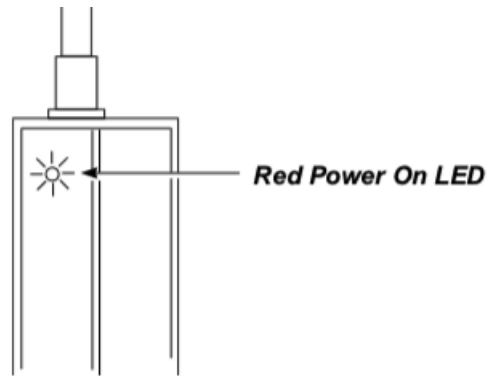

Figure 64: Red Power On LED

6. Ensure that Switch 1 (*sw1*), see Figure 54, is set to the correct range:

Fume Hood Size	Sash Beam Range	sw1 Setting
0 to 10' (up to 3000mm)	Short	Off
10' to 16' (3000 to 5000mm)	Long	On

7. Ensure that Switch 2 (*sw2*) (Figure 63) is set to **Off** (Operation Mode).

8. Ensure that Switch 3 (*sw3*) is set to **On** (Normal Operation).

9. Set Switch 4 (*sw4*) to **On**. A buzzer will then sound when the beam is broken, this aids the setting up of the beam.

The signal LED indicates beam status:

- Green if the detection area is clear.
- Red if the area is not clear.

10. Turn the gain potentiometer anti-clockwise, to the minimum. The transmitter and receiver can no longer sense each other.

11. Slowly adjust the gain potentiometer (Figure 63) clockwise (to maximum) until the transmitter and receiver can sense each other, for example, the receiver can detect the beam sent from the transmitter.

12. Set *sw3* to **Off** to store the settings.

13. Turn the gain potentiometer approximately 5 degrees clockwise to ensure sufficient gain.

14. Use a glass object to test whether it breaks the beam. Do this across the entire open face of the fume hood.

If the glass object does not break the beam, adjust the gain potentiometer counter-clockwise until inserting the glass object breaks the beam.

15. If required, set *sw4* to **Off** to disable the buzzer.

If the sash light beams intermittently sense the glass object, ensure *sw1* is set to Off (short range) and repeat steps 5 to 14 above.

If the beam is broken when the path is clear and adjusting the Gain Potentiometer does not resolve this situation, either:

Switch *sw2* **On** (Diagnostic mode). After approximately 15 seconds the *RX ERR* and *TX ERR* LEDs (Figure 63) will indicate if there is a faulty beam:

- *RXERR* Red LED **On** – Faulty receiver
- *TXERR* Red LED **On** – Faulty transmitter

Or:

Clean or replace the faulty component and set *sw2* to **Off** (Operation mode).

#### 7.6.8 *Tilt switch*

No user calibration of the Tilt Switch is possible. When using a Tilt Switch, ensure that the top panel of the fume hood is closed before switching on the Auto Sash Control Unit.

#### 7.6.9 *Sash position sensor*

No user calibration of the Sash Position Sensor is possible. The sensor provides sash position data to the Auto Sash Controller, relative to its starting position.

#### 7.6.10 *Personnel sensor*

The sensor is self-calibrating and does not need adjusting.

For optimum performance, ensure the detection field in front of the fume hood is clear from objects and personnel when powering up the Auto Sash Control Unit.

The sensor will be fully operational approximately 10 seconds after the sensor is powered up.

The LED on the sensor will be green if the detection area is clear and red if it is not clear.

To test that the sensor is operational, listen to whether the internal relay clicks when standing in front of the fume hood and when walking away.

#### 7.6.11 *Sash low switch*

No user calibration of the Sash Low Switch is possible.

#### 7.6.12 *Auto Stop*

The Auto stop feature uses the calibrated middle position as the stop position

## 8. *Configuration*

The AFA4000/E and AFA4000/E/AS Airflow Monitors can be configured using a variety of set up programs, each designed for a specific application with a combination of inputs, outputs and push buttons.

The monitor can be re-configured through the key pad and menu system or by connection to a laptop or PC.

This allows the fume cupboard manufacturer to stock standard units and configure the monitors.

See the

Operator display panel menu section (section 3.5) for instructions on how to navigate the menus.

## 8.1 *AFA4000/E configuration menus*

To configure the AFA4000/E Airflow Monitor, navigate to **Main Menu > Set up Monitor > Configure** to display the Monitor Set up Menu.

Press the ↓ button to scroll down the menu list and press **Mute** to select the required option.

*Note: The Configure menu is password protected. The default password is 0 0 0 0.*

*Note: The Monitor Set up Menu also includes Calibration and Password sub-menus which are used by engineers to set up the system. If you enter any of the Monitor Set up sub-menus by accident, press the ↑ and ↓ arrows together when the password is requested to return to the Monitor Set up menu.*

### 8.1.1 Monitor config menu

*Note:* A pop-up dialog box will show if a relay is already allocated to another option.

Menu item	Option	Instructions
Cal Config Menu	<b>Cal config menu</b>	See section 8.1.1.1.
Hours Counter	<b>Hours counter menu</b>	See section 8.1.1.2.
Input (1, 2 or 3)	Input activation	Select the activation type: <ul style="list-style-type: none"> <li>• Closed contact</li> <li>• Open contact</li> <li>• None</li> <li>• Analog</li> </ul>
	Input function	Select the function: <ul style="list-style-type: none"> <li>• Night Setback</li> <li>• Alarm Disable</li> <li>• None</li> <li>• Temperature</li> <li>• Fire Alarm</li> <li>• Mute</li> <li>• Fan Stop</li> <li>• Mains Fail</li> <li>• Sash Warning</li> <li>• High/Low</li> <li>• Sash High</li> <li>• Emergency</li> <li>• Ext. Alarm</li> <li>• Fire Alarm</li> </ul>
Relay Output (1, 2 or 3)	Relay activation	Select the activation type: <ul style="list-style-type: none"> <li>• Closed contact</li> <li>• Open contact</li> </ul>
Pushbutton (1,2, or 3)	Pushbutton activation	Enable or disable the timer.
	Pushbutton function	<ul style="list-style-type: none"> <li>• Fan</li> <li>• Ext Fan</li> <li>• D/F Fan</li> <li>• Sockets</li> <li>• S/B O/R</li> <li>• Purge</li> <li>• Light</li> <li>• UV Lights</li> <li>• Pump</li> <li>• Gas</li> <li>• High/Low Speed</li> <li>• Emergency</li> </ul>
Auto Dim Screen	Auto dim screen	Set the time to auto dim the screen.
Low Air Timer	Low air repeat time	Enable or disable the timer.

Menu item	Option	Instructions
	Low air repeat time	If the timer is enabled, set the time.
Low Air Relay	Low air relay	Select the required relay: <ul style="list-style-type: none"> <li>• None</li> <li>• Output 1 – Output 3</li> </ul>
	Allow inhibit	Enable or disable the inhibit screen feature.
High Air Relay	High air relay	Select the required relay: <ul style="list-style-type: none"> <li>• None</li> <li>• Output 1 – Output 3</li> </ul>
	Alarm Disable Relay	Select the required relay: <ul style="list-style-type: none"> <li>• None</li> <li>• Output 1 – Output 3</li> </ul>
Sash High	Repeat timer	Enable or disable the timer.
	Sash high time	If the timer is enabled, set the time.
	Sash high relay	Select the required relay: <ul style="list-style-type: none"> <li>• None</li> <li>• Output 1 – Output 3</li> </ul>
High Low Relay	High/low relay	Select the required relay: <ul style="list-style-type: none"> <li>• None</li> <li>• Output 1 – Output 3</li> </ul>
Night Set Back	Night set-back	Select from: <ul style="list-style-type: none"> <li>• Maintain Low Air</li> <li>• Reduce Low Air</li> </ul>
	Night set-back alarm	If Reduce Low Air is selected, set the low limit for the air flow.
	Night set-back relay	Select the required relay: <ul style="list-style-type: none"> <li>• None</li> <li>• Output 1 – Output 3</li> </ul>



Menu item	Option	Instructions
Night Set Back Mute	Night set-back mute	Enable or disable the night set-back mute.
External Alarm	LED on/off screen	Enable or disable the LED.
	Display on / off	Enable or disable the display.
	External alarm relay	Select the required relay: <ul style="list-style-type: none"> <li>• None</li> <li>• Output 1 – Output 3</li> </ul>
Fire Alarm	Fire alarm relay	Select the required relay: <ul style="list-style-type: none"> <li>• None</li> <li>• Output 1 – Output 3</li> </ul>
Protocol	Protocol	Select the required protocol: <ul style="list-style-type: none"> <li>• Modbus</li> <li>• BACnet</li> <li>• TEL PC</li> <li>• TEL AFA5000</li> <li>• TELBUS</li> </ul> <p><i>Note: The TEL protocols are used to connected to TEL Config Manager software and the TEL AFA5000 Room Space Controller, the Modbus Slave ID is used when set to TEL protocol.</i></p>
Modbus Settings	<b>MODBUS settings menu</b>	See section 8.1.1.3.
BACnet settings	<b>BACnet settings menu</b>	See section 8.1.1.4.
Sensor Error Options	Buzzer on / off	Enable or disable the buzzer.
	Sensor error relay	Select the required relay: <ul style="list-style-type: none"> <li>• None</li> <li>• Output 1 – Output 3</li> </ul>
Sash Warning Timer	Sash warning time	Set the time.
	Sash warn rpt alarm	Enable or disable the alarm.

Menu item	Option	Instructions
Sash Warning Timer (cont.)	Sash warn rpt time	If the alarm is enabled, set the repeat time.
Factory Settings	Enter password	Use ↑ / ↓ to enter password, then press <b>Mute</b> .
	Restore factory setting	Press Mute to restore the factory settings. Press ↓ to return to the <b>Monitor config menu</b> (section 8.1.1).
Done	Return to <b>Monitor set up</b> menu.	

#### 8.1.1.1 Cal config menu

*Note:* Use ↑ / ↓ to increase or decrease parameter values, then press **Mute** to save the new value.

Menu item	Instructions
Display Units	Select the required display units: <ul style="list-style-type: none"> <li>• m/sec</li> <li>• fpm</li> </ul>
Low Air Alarm	Set the low air flow alarm threshold.
Low Air Cutoff	Enable or disable the low air cut-off. If enabled, set the low air flow threshold.
High Air Cutoff	Enable or disable the high air cut-off. If enabled, set the high air flow threshold.
Warning Air	Set the air flow warning threshold.
Warning Air Reset	Set the air flow warning reset level.
High Air Alarm	Enable or disable the high air alarm. If enabled, set the high air flow threshold.
Lower Air Fluctuation	Set the lower air fluctuation level (%).
Higher Air Fluctuation	Set the higher air fluctuation level (%).
Low/High Air Difference	Set the low / high air difference value.

Menu item	Instructions
Warning to Alarm Time	Set the warning to alarm time.
Alarm to Warning Time	Set the alarm to warning time.
Show Airflow	Select <b>Enable</b> to display the airflow value in the display or <b>Disable</b> to display only the status.
Show Timeline/bargraph	Select the required display: <ul style="list-style-type: none"> <li>• timeline</li> <li>• bargraph</li> </ul>
Show Alarm Limits	Select whether to display the alarm limits on the bargraph, by selecting <b>Enable</b> or not, by selecting <b>Disable</b> .
Audible Alarm	Select <b>Enable</b> to sound the audible alarm or <b>Disable</b> not to sound it.
Sensor Difference	Set the sensor difference (%).
Display Smoothing	Set the sensor difference (seconds).
Keyboard Click	Enable or disable the keyboard click.
Done	Return to the <b>Monitor config menu</b> (section 8.1.1).

#### 8.1.1.2 Hours counter menu

Menu item	Instructions
Enable Counter	Enable or disable the hours counter.
Max Hours	Set the maximum hours for the hours counter. (0 – 5000 hours).
Show Alarm	Select whether to display the alarm, by selecting <b>Enable</b> or not, by selecting <b>Disable</b> .
Reset Counter	Select <b>Yes</b> to reset the counter.
Done	Return to the <b>Monitor config menu</b> (section 8.1.1).

### 8.1.1.3 MODBUS settings menu

Menu item	Instructions
Slave ID	Set the Slave ID.
Baudrate	Set the Baudrate: <ul style="list-style-type: none"> <li>• 1200</li> <li>• 2400</li> <li>• 4800</li> <li>• 9600</li> <li>• 14400</li> <li>• 19200</li> <li>• 38400</li> <li>• 57600</li> </ul>
Parity	Set the parity: <ul style="list-style-type: none"> <li>• None</li> <li>• Odd</li> <li>• Even</li> </ul>
Done	Return to the <b>Monitor config menu</b> (section 8.1.1).

### 8.1.1.4 BACnet settings menu

Menu item	Instructions
Device Instance	Use the ↑ / ↓ buttons to set the value for a digit, then press <b>Mute</b> to go to the next digit.
Station ID	Set the Station ID.
Baudrate	Set the Baudrate: <ul style="list-style-type: none"> <li>• 1200</li> <li>• 2400</li> <li>• 4800</li> <li>• 9600</li> <li>• 14400</li> <li>• 19200</li> <li>• 38400</li> <li>• 57600</li> <li>• 76800</li> </ul>
Parity	Set the parity: <ul style="list-style-type: none"> <li>• None</li> <li>• Odd</li> <li>• Even</li> </ul>

Menu item	Instructions
Max Masters	Set the maximum number of AFA4000 devices on the network.
Done	Return to the <b>Monitor config menu</b> (section 8.1.1).

## 8.2 Control settings

A number of control settings must be considered to give good control of the fume cupboard face velocity. These settings are adjustable in the *ECON Configure Menu*.

To access the ECON Configure Menu, navigate to **Main Menu > Set up Monitor > Configure > Econ Config**.

Press the ↓ button to scroll down the menu list and press **Mute** to select the required option.

*Note: The Configure menu is password protected. The default password is 0 0 0 0.*

*Note: The Monitor Set up Menu also includes Calibration and Password sub-menus which are used by engineers to set up the system. If you enter any of the Monitor Set up sub-menus by accident, press the ↑ and ↓ arrows together when the password is requested to return to the Monitor Set up menu.*

### 8.2.1 ECON Configure Menu

item	Instructions
Manual / Automatic	<p>Control output voltage can be set to Manual or Automatic control.</p> <p><i>Note: The controller displays Manual, Automatic, High Set Point or Low Set Point above the output bar graph at the top of the screen to show the current output status.</i></p>
	<p><b>Manual:</b> The output is displayed as 0 – 100%. Use the ↑ and ↓ arrows to adjust the value. Press <b>Mute</b> to select the required value. The output will remain fixed at this value.</p> <p><i>Note: If the Output Type is set to Valve, the manual output is relative to the damper position. If the Output Type is set to Damper or Inverter, the manual output is relative to Volume.</i></p>
	<p><b>Automatic:</b> The output automatically adjusts continuously to make the displayed face velocity equal to the Set Point (see below). Automatic is used for VAV control.</p>
High Set Point	<p>Used for the following:</p> <ul style="list-style-type: none"> <li>• to enter the required set point face velocity for the VAV control</li> <li>• to enter the High Set Point face velocity in occupied mode when Dual Set Point control is used.</li> </ul>
Low Set Point	<p>Used to enter the required Low Set Point velocity in unoccupied mode when Dual Set Point control is used.</p>

item	Instructions
Output Type	<p>The 0 – 10 Vdc control output can be set to the following options:</p>
Damper:	<p>The damper output is linearised for a butterfly-type damper so that the output is proportional to volume and not damper position. The linearised output gives increased speed of response when the sash is opened.</p> <p>This setting should be used for TEL supplied Econ VAV dampers.</p> <p>The damper output is direct and 10V = Max volume.</p>
Inverter:	<p>The inverter output is proportional to volume when used with an inverter and is reversed so 0V = Max volume.</p>
Valve:	<p>The valve output is proportional to damper position. For example, 50% = 45° on a 90° actuator. The output is direct and 0V = Max volume.</p>

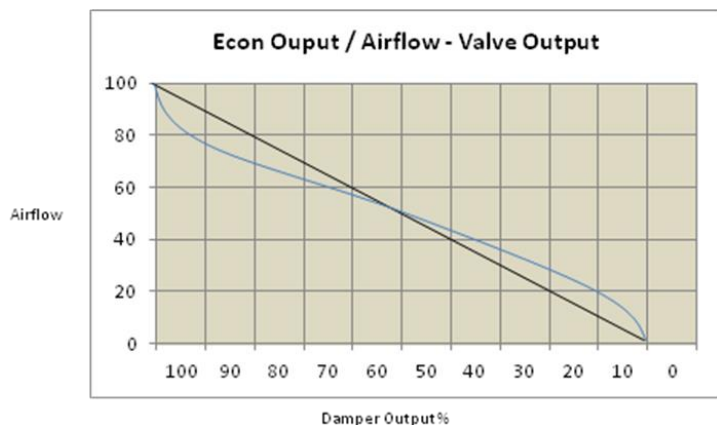
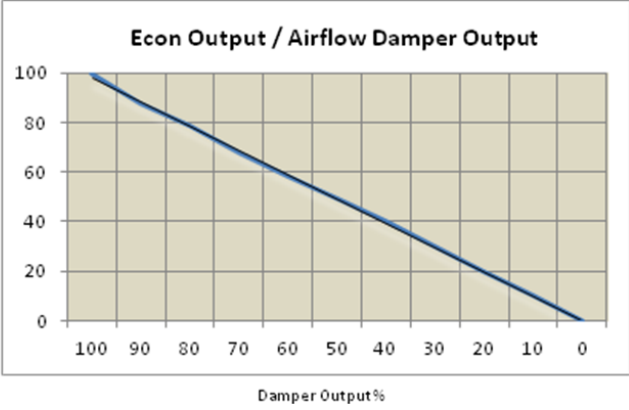

Figure 65: Typical butterfly damper curve to face velocity (Valve Output)

item	Instructions
Output Type (cont.)	 <p style="text-align: center;"><b>Econ Output / Airflow Damper Output</b></p>
	<p><i>Figure 66: Typical linearised butterfly damper curve to face velocity (Damper Output)</i></p>
	<p><i>Note: Performance is dependent on damper and fume cupboard leakage.</i></p>
MIN Output	<p>Used when Pushbutton III is set to Min / Run / Max.</p> <p><i>MIN Output</i> sets the damper or inverter to a minimum extract volume when the fume cupboard is not in use and the MIN function is selected.</p> <p>Output range: 0 – 100%</p>
MAX Output	<p>Used when Pushbutton III is set to Min / Run / Max.</p> <p><i>MAX Output</i> sets the damper or inverter to a maximum extract volume in an emergency when the MAX function is selected.</p> <p>Output range: 0 – 100%</p>
Low Limit	<p>Used to set up the minimum extract rate from the fume cupboard in automatic VAV operation. As the sash is lowered, the damper progressively closes, or extract fan slows down, to reduce the extract volume and maintain the set point face velocity. The Low Limit sets a minimum damper position to prevent the volume reducing too far.</p> <p>As the sash is lowered, the displayed face velocity will be at the set point value until the damper reaches the Low Limit.</p>



item	Instructions
	<p>As the sash is closed further, the damper will not move, and the displayed face velocity will increase. The increased velocity represents a volume through the fume cupboard in the sash closed position equal to approximately 15 – 25% of the design volume with the sash at the maximum safe working opening.</p> <p><i>Note: Typical minimum volume requirement is set to achieve 6 ach/hr room ventilation when all sashes are closed.</i></p>
High Limit	<p>Used to set up the maximum extract rate from the fume cupboard in automatic VAV operation. As the sash is raised, the damper progressively opens, or the extract fan speeds up, to increase the extract volume and maintain the set point face velocity.</p> <p>The High Limit sets a maximum damper position to prevent the volume from increasing too far.</p> <p><i>Note: In most installations, the High Limit is set to 100%.</i></p>
Output Range	<p>Used to select the correct output voltage range for damper control for the VAV or inverter speed control of the extract fan.</p> <ul style="list-style-type: none"> <li>• Damper: 2 – 10 V</li> <li>• Valve: 2 – 10 V</li> <li>• Inverter: 0 – 10 V</li> </ul>
Prop Band	<p>The Prop Band (Proportional Band) is the main control parameter for the automatic VAV control. It acts as the sensitivity of the control system.</p> <p>If it is set too low, a very small change in the measured face velocity will result in a large change in the output, and damper or inverter will become unstable.</p> <p>If it is set too high, a large change in the measured face velocity is required to give a small change in the output, and the damper or inverter will react very slowly.</p>

item	Instructions				
Prop Band (cont.)	<p>The ideal setting is to select a value that is as small as possible which gives stable control of the damper or inverter without 'hunting'. (Refer to section 0 for a practical explanation of how to set this value on a fume cupboard).</p> <p>Example Prop Band gain settings:</p>				
	P Band %	Set Point m/sec	Integral Secs	Output = 0% @	Output = 100% @
	50	0.50	0	0 m/sec	1.00 m/sec
	30	0.50	0	0.20 m/sec	0.80 m/sec
	10	0.50	0	0.40 m/sec	0.60 msec
	<p>The Prop Band gain is 0 – 100% of full scale (1.00 m/sec), so if a Prop Band of 50% = 0.5 m/sec, the output will be at zero when the airflow is 0.5 m/sec below the set point and be at 100% when the airflow is 0.5 m/sec above the set point.</p>				
Integral Time	<p>The Integral Time is the correction action of the control system. If only proportional control (prop band) is used, any error is between the actual measured face velocity and the set point face velocity. The Integral action takes this error and adjusts the control output in a series of small steps to bring the measured value to the same as the set point value. The time taken to correct the measured value depends on how many times the controller makes the small adjustments over a period of time.</p> <p>The Integral Time action is shown on the menu in Seconds. Increasing the value will give a faster correction time.</p> <p>If the value is set too low, it will take a long time for the measured value to reach the set point. If it is set too high, the measured value will correct very quickly but may 'overshoot' in each direction and cause 'hunting'.</p>				

item	Instructions
Integral Time (cont.)	The ideal setting for this value is to select a value as high as possible that gives stable control of the damper or Inverter without 'hunting'. Refer to section 0 for a practical explanation of how to set this value on a fume cupboard.
Boost Duration	<p>This function is used in conjunction with the Sash position sensor for VAV control.</p> <p>When the sash is opened, the output drives to a calculated position for a brief time period before the output switches back to face velocity control. The Boost Duration is the time period that the output is held before switching back to face velocity control.</p> <p>This parameter should not require an on-site setting and is factory set to 5 seconds.</p>
Boost Percentage	This function is used to adjust the pre-determined output position that the damper drives to when the boost function is active.
Done	Return to the <b>Monitor Config menu</b> (section 8.1.1).

## 8.3 Control Setup Guide

The Prop Band and Integral Time parameters must be adjusted in order to achieve good VAV control. Complete the calibration procedure first (section 7), then use this guide to help find the best values for each individual installation.

*Note: The information in this section describes how to set up and calibrate a single fume cupboard incorporating the AFA4000/E VAV controller. Most VAV fume cupboard installations use a common extract fan, complete with a fresh air bleed system connected to multiple fume cupboards. Always consider the commissioning and setting up of the system as a whole before you attempt to set up the individual fume cupboard controls. This is particularly important when the extract system has a diversity factor (i.e. the extract fan is only capable of operating a percentage of the fume cupboards at full volume).*

1. Set **Integral Time** to 0 seconds to give proportional control only.
2. Set **Prop Band** to 30%.
3. Set the Econ to **Automatic** and select **Run**.
4. At the design sash height, for example, 500 mm, the face velocity will be close to the set point, for example, 0.5 m/sec.
5. When the sash is lowered to 100 mm, the face velocity increases.
6. Adjust the **Prop Band** value in steps up or down until the face velocity at 100 mm is approximately 0.75 m/sec and check that the face velocity is stable (i.e. it is not oscillating). The Prop Band value should be approximately 15 to 35 %.

If the Prop Band is set to a low value, e.g. 10%, the sensitivity will be high and the output may oscillate when the sash is lowered.

If the Prop Band is set to a high value, e.g. 50%, the sensitivity will be low and the face velocity at 100 mm will be too high.

At this stage the measured face velocity will probably not be at the set point with the sash at 500 mm. The function of this first step is to get stable control at 500 mm and at 100 mm with no 'hunting'.

7. When the correct Prop Band is determined, set up the **Integral Time** to correct the measured face velocity to the set point value.  
Initially set the **Integral Time** to 10 seconds.
8. Now when the sash is lowered, the Integral will reduce the face velocity back to the set point over a specified time. If the 'correction time' is too slow, increase the **Integral Time**

(seconds) in steps of 5 until the face velocity controls back to the set point over an acceptable time.

If the **Integral Time** is set too low, the face velocity will take too long to control back to the set point when the face velocity changes.

If the **Integral Time** is set too high, the Integral may over-compensate and create overshoot and give unstable control.

Set the **Integral Time** to approximately 10 – 30 seconds.

9. The controller has an **Auto Tune** correction algorithm that increases the speed of response once the measured airflow value drops below the set point value if the Prop band and Integral settings are incorrect. The algorithm is only active when the measured airflow is below the set point and the Integral value is set greater than zero.

## 8.4 AFA4000/E/AS configuration menus

*Note: The Auto Sash menus are only available when the Auto Sash is connected.*

To configure the AFA4000/E/AS Airflow Monitor, navigate to **Main Menu > Set up Auto Sash > Setup Menu** to display the Menu options.

Press the ↓ button to scroll down the menu list and press **Mute** to select the required option.

### 8.4.1 Auto Sash setup menu

*Note: The Setup menu is password protected. The default password is 1 0 0 1.*

*Note: Select the option **Back to Setup Menu** to return to the next option in the Auto Sash setup menu.*

To change options in the Auto Sash setup menu:

1. Press **Mute** to enter edit mode. The '>' symbol next to the parameter is underlined.
2. Press the ↑ / ↓ buttons to scroll through the options.
3. Press **Mute** to select the option. The '>' symbol underline disappears.
4. Press the ↓ button to scroll down to the next menu option.

Menu item	Option	Instructions
System Profile		Select the required system profile: <ul style="list-style-type: none"> <li>• Bench type</li> <li>• Walk in</li> <li>• DDA</li> </ul>
Keypad Settings	Audible Alarm Obstruction	Choose the setting: <ul style="list-style-type: none"> <li>• On</li> <li>• Off</li> </ul>
	Audible Alarm Sash Fault	Choose the setting: <ul style="list-style-type: none"> <li>• On</li> <li>• Off</li> </ul>
	Audible Alarm Sash Lock	Choose the setting: <ul style="list-style-type: none"> <li>• On</li> <li>• Off</li> </ul>
Sash settings	1. Enable / disable	Choose the setting to permanently enable or disable the S1 drive via the menu or keypad: <ul style="list-style-type: none"> <li>• On (via menu)</li> <li>• Off</li> <li>• User (via keypad)</li> </ul>
	2. Sensors	Choose the setting: <ul style="list-style-type: none"> <li>• Disabled / Enabled</li> <li>• Disabled / NC Contact / NO Contact</li> <li>• Disabled / Enabled</li> <li>• Yes / No</li> <li>• Disabled / NC Contact / NO Contact</li> <li>• Yes / No</li> <li>• SP1-50 / SG1-120</li> </ul>
	Tilt Switch	• Disabled / Enabled
	Light Curtain	• Disabled / NC Contact / NO Contact
	Light Curtain Test	• Disabled / Enabled
	Auto Clear Obst Alarm	• Yes / No
	Personnel Sensor	• Disabled / NC Contact / NO Contact
	Personnel Power Cycle	• Yes / No
	Sash String Type	• SP1-50 / SG1-120
	<i>Back</i>	

Menu item	Option	Instructions
Sash settings (cont.)	3. Motor Drive	Choose the setting:
	Motor Voltage	<ul style="list-style-type: none"> <li>6-24V (Password protected)</li> </ul>
	Motor Speed Open	<ul style="list-style-type: none"> <li>30-100%</li> </ul>
	Motor Speed Close	<ul style="list-style-type: none"> <li>30-100%</li> </ul>
	Clutch Off Delay	<ul style="list-style-type: none"> <li>0.0-1.0 Seconds</li> </ul>
	Over Current Open	<ul style="list-style-type: none"> <li>50-3000mA</li> </ul>
	Over Current Close	<ul style="list-style-type: none"> <li>50-3000mA</li> </ul>
	Over Current Delay	<ul style="list-style-type: none"> <li>0.0-1.0 Seconds</li> </ul>
	Stall Detect Sensitivity	<ul style="list-style-type: none"> <li>1-6</li> </ul>
	Stall Detect Delay	<ul style="list-style-type: none"> <li>1-5 Seconds</li> </ul>
	Advanced Settings	<ul style="list-style-type: none"> <li>(Password Protected Options)</li> <li>Slow Down Zone 10-100mm</li> <li>Slow Down to 10-100mm/s</li> <li>Accelerate Fast Over 0.1-5.0 Seconds</li> <li>Decelerate Fast Over 0.1-5.0 Seconds</li> <li>Decelerate Slow Over 0.1-5.0 Seconds</li> <li><i>Back</i></li> </ul>
	Motor Current Display	<ul style="list-style-type: none"> <li>Off / Live / Max</li> </ul>
Motor Current 0-10V	<ul style="list-style-type: none"> <li>Off / Sash 1 / Sash 2</li> </ul>	
	<i>Back</i>	
4. Calibration		Follow the on-screen instructions to manually calibrate the sash position sensor and motor direction.

Menu item	Option	Instructions
Sash 1 settings (cont.)	5. Auto Close	Choose the setting:
	Auto Close	<ul style="list-style-type: none"> <li>• Disable / Enable</li> </ul>
	Auto Close Delay	<ul style="list-style-type: none"> <li>• 0-3600 Seconds</li> </ul>
	Auto Close Alarm	<ul style="list-style-type: none"> <li>• 0-10 Seconds</li> </ul>
	Close Threshold	<ul style="list-style-type: none"> <li>• 0-100mm</li> </ul>
	<i>Back</i>	
	6. Tiptronic	Choose the setting:
	Tiptronic	<ul style="list-style-type: none"> <li>• Disable / Enable</li> </ul>
	Minimum Tip Time	<ul style="list-style-type: none"> <li>• 100-300ms</li> </ul>
	Maximum Tip Time	<ul style="list-style-type: none"> <li>• 500-1500ms</li> </ul>
	<i>Back</i>	
	7. Auto Open	Choose the setting:
	Auto Open	<ul style="list-style-type: none"> <li>• Disable / Enable</li> </ul>
	Auto Open Delay	<ul style="list-style-type: none"> <li>• 0-10 Seconds</li> </ul>
	Auto Open Alarm	<ul style="list-style-type: none"> <li>• 0-10 Seconds</li> </ul>
	<i>Back</i>	
	8. Auto Lock	Choose the setting:
	Auto Lock	<ul style="list-style-type: none"> <li>• Disable / Enable</li> </ul>
	Auto Lock Alarm	<ul style="list-style-type: none"> <li>• 1-30 Minutes</li> </ul>
	<i>Back</i>	
	9. Auto Stop	Choose the setting:
	Auto Stop	<ul style="list-style-type: none"> <li>• Disable / Enable</li> </ul>
	Auto Stop Distance	<ul style="list-style-type: none"> <li>• 5-99mm</li> </ul>
	Auto Stop Delay	<ul style="list-style-type: none"> <li>• 1-5 Seconds</li> </ul>
	<i>Back</i>	



---

## Notes

---

1. **TipTime** is the time threshold for the Auto Sash to detect manual movement, to allow manual operation. When movement is detected within the set times the sash will automatically drive to the calibrated position.

For example, when the TipTime range is set to 100 ms (min) and 1000 ms (max), and the Auto Sash detects movement for more than 1000 ms, it will allow the sash to be moved manually to any position. If the Auto Sash detects movement within the min and max time settings the sash will automatically drive to the calibrated position, downward movement will drive the sash fully closed, upward movement will drive the sash to the mid position.

2. **Stall Detect Sensitivity** sets the boundary of the Sash Fault alarm, where 1-6 = 1-6mm/sec sash velocity. The Stall Detect Delay is a delay period before the alarm activates.

For example, when the Sensitivity is set to 4 and the Delay is set to 2 seconds, the Sash Fault alarm will activate 2 seconds after the sash velocity <4mm/sec.

3. **Auto Stop** engages the clutch to stop the sash moving when the sash is manually raised above the mid calibrated position. The Auto Stop Distance is the distance above the mid position where the stop will engage. The sash will return to the mid position after the Auto Stop Delay time.

For example, with the Distance set to 5mm and the Delay set to 2 seconds, when the sash is manually raised the stop will engage 5mm above the mid position and the sash return to the mid position after a 2 second delay.

4. **Motor Over Current Open and Closed** parameters are used to stop the sash if the motor current exceeds the set values when the sash is driving.

Menu item	Option	Instructions
BMS Input Settings	Fire Alarm	Set the Fire Alarm BMS input: <ul style="list-style-type: none"> <li>• Disabled</li> <li>• Input 1 – 4 open</li> <li>• Input 1 – 4 closed</li> </ul>
	Open Sash	Set the Open Sash BMS input: <ul style="list-style-type: none"> <li>• Disabled</li> <li>• Input 1 – 4 open</li> <li>• Input 1 – 4 closed</li> </ul>
	Close Sash	Set the Close Sash BMS input: <ul style="list-style-type: none"> <li>• Disabled</li> <li>• Input 1 – 4 open</li> <li>• Input 1 – 4 closed</li> </ul>
	EV Open Sash	Set the EV Open Sash BMS input: <ul style="list-style-type: none"> <li>• Disabled</li> <li>• Input 1 – 4 open</li> <li>• Input 1 – 4 closed</li> </ul>
	EV Close Sash	Set the EV Close Sash BMS input: <ul style="list-style-type: none"> <li>• Disabled</li> <li>• Input 1 – 4 open</li> </ul> Input 1 – 4 closed
	Foot SW Open	Set the Foot SW Open BMS input: <ul style="list-style-type: none"> <li>• Disabled</li> <li>• Input 1 – 4 open</li> </ul> Input 1 – 4 closed
	Foot SW Closed	Set the Foot SW Closed BMS input: <ul style="list-style-type: none"> <li>• Disabled</li> <li>• Input 1 – 4 open</li> </ul> Input 1 – 4 closed

Menu item	Option	Instructions
BMS Output Settings	Alarm Sounder	Enable / Disable the remote alarm sounder.
	Analog Volts	Select the required analogue voltage output for sash position indication: <ul style="list-style-type: none"> <li>• 0 – 10V</li> <li>• 1 – 10V</li> <li>• 0 – 5V</li> <li>• 1 – 5V</li> </ul>
	Analogue Current	Select the required output current for sash position indication: <ul style="list-style-type: none"> <li>• 0 – 20mA</li> <li>• 4 – 20mA</li> </ul>
	Relays 1 to 4: RLY1, RLY2, RLY3, RLY4	Select the required settings for the relay: <ul style="list-style-type: none"> <li>• Always Open</li> <li>• Always Closed</li> <li>• Open on Sash Alarm</li> <li>• Close on Sash Alarm</li> <li>• Open on Obstruction</li> <li>• Close on Obstruction</li> <li>• Open on Personnel</li> <li>• Close on Personnel</li> <li>• Open on Sash Open</li> <li>• Close on Sash Open</li> <li>• Open on Sash Locked</li> <li>• Close on Sash Locked</li> </ul>
Exit and Abandon Changes		Return to Main <a href="#">menu</a> without saving
Exit and Save Changes		Return to Main <a href="#">menu</a> saving all changes

## 8.4.2 Auto Sash engineering menu

*Note: The Engineering menu is password protected. The default password is 1 2 1 2.*

The Engineering menu is used by TEL Ltd engineers to test the Auto Sash Controller inputs and outputs.

To change options in the Engineering menu:

- 1 Press **Mute** to select the Engineering menu item.
- 2 The '>' symbol next to the first option is underlined.
- 3 Press the ↑ / ↓ buttons to scroll through the editable parameters for that option. The current editable parameter is underlined, for example, > TLP POS F R shows that the POS parameter will be selected when **Mute** is pressed.
- 4 Press **Mute** to select the parameter. Adjust the parameter as described in the table below.
- 5 Repeat this process until all the required parameters have been adjusted. Press the ↑ / ↓ buttons until the '>' symbol is underlined again.
- 6 Press **Mute** to scroll down to the next option.

*Note: To exit the current parameter list at any time, press the ↑ / ↓ buttons together to return to the Engineering menu.*

*Note: Select the option **Back to Engineering Menu** to return to the next option in the Auto Sash engineering menu.*

Menu item	Option	Instructions
Input / Output	≥ TLP POS F R	Sash 1 position.
Diagnostics	S1 X-X 0.0 - -	<p>An active output is shown with an X beneath it. In the example shown here, the tilt switch (T) and personnel sensor (P) are active and the light curtain (L) is inactive as shown by the X-X on the second row.</p> <p>Parameters are:</p> <ul style="list-style-type: none"> <li>T      Tilt switch</li> <li>L      Light curtain</li> <li>P      Personnel sensor</li> <li>POS   Sash position. When in use, the value goes from 0 (sash closed) to 100% (sash fully open) to show the position of the sash.</li> <li>F      When <b>Mute</b> is pressed, an X appears in the bottom row to indicate that the motor is driving forward.</li> <li>R      When <b>Mute</b> is pressed, an X appears in the bottom row to indicate that the motor is driving in reverse.</li> </ul>

Menu item	Option	Instructions
Input / Output	≥ TLP POS F R	Sash 2 position.
Diagnostics (cont.)	S2 - - - FAULT - -	This is active for the second sash, if the Dual Auto Sash controller is in use. The parameters are the same as for Sash 1 position, but they refer to the second sash.
	≥ I1234 R1234 A	Inputs and outputs.
	BMS - - - - - - - -	<p>I1234    Inputs 1 - 4. An X displays under an input (I1234) if that input is active.</p> <p>R1234    Relay outputs 1 – 4. Press <b>Mute</b> to activate the selected relay. An X displays under the relevant relay.</p> <p>A        Alarm output. Press <b>Mute</b> to put 24 V onto this output. This is useful to power an external light or sounder when the alarm is triggered e.g. for a sash fault.</p>

Menu item	Option	Instructions
Input / Output	≥ 0-10V 0-20mA	Output test settings.
Diagnostics (cont.)	BMS 10V 20mA	<p>Select a voltage or current for the outputs for testing.</p> <p>Editable parameters are:</p> <ul style="list-style-type: none"> <li>• 0-10V. Press <b>Mute</b> to scroll through the options: <ul style="list-style-type: none"> <li style="margin-right: 20px;">• 0V</li> <li>• 6V</li> <li>• 2V</li> <li>• 8V</li> <li>• 4V</li> <li>• 10V</li> </ul> </li> <li>• 0-20mA. Press <b>Mute</b> to scroll through the options: <ul style="list-style-type: none"> <li style="margin-right: 20px;">• 0mA</li> <li>• 12mA</li> <li>• 4mA</li> <li>• 16mA</li> <li>• 8mA</li> <li>• 20mA</li> </ul> </li> </ul>
Factory Tests	Test Main Board 1187A (harness)	Follow the on-screen instructions to carry out the test.
	Test PIM Module 1187B (harness)	Follow the on-screen instructions to carry out the test.
	Test Keypad 1186	Follow the on-screen instructions to carry out the test.
Technical Information	S1 Motor Volts	Current setting of the Sash 1 motor voltage.
	S1 Motor Dir	Current setting of the Sash 1 motor direction.
	S1 PIN Type	Current setting of the Sash 1 PIN type.
	S1 String Type	Current setting of the Sash 1 String type.
	S1 String Dir	Current setting of the Sash 1 String direction.
	S1 Top Position	Current setting of the Sash 1 top position.

Menu item	Option	Instructions
Technical Information (cont.)	S1 Mid Position	Current setting of the Sash 1 middle position.
	S1 Bot Position	Current setting of the Sash 1 lower position.
Change Password for Setup Menu	Setup Menu Password	The current password is displayed. <ol style="list-style-type: none"> <li>1. Press <b>Mute</b> to select Edit mode (the '&gt;' symbol will be underlined).</li> <li>2. Use ↑ / ↓ to increase or decrease the password as required.</li> <li>3. Press <b>Mute</b>.</li> <li>4. Press the ↓ buttons to display the Exit options.</li> </ol>
	Exit and Save Changes	Press <b>Mute</b> to save the password changes and to exit back to the Main Menu.
	Cancel Back to Engineering Menu	Press <b>Mute</b> to exit <u>without</u> saving the password changes.



## 8.5 Dual Output – Econ Output 2

The AFA4000/E has a second 0 – 10V control output that is available when the Econ power supply unit is fitted. It can be configured for 4 functions using the pushbutton menu.

Function	Additional requirements	Description
Bleed damper	<ul style="list-style-type: none"> <li>Econ power supply unit</li> </ul>	0 – 10 Vdc output to control a secondary damper e.g. fresh air bleed or supply air damper
Volume pressure	<ul style="list-style-type: none"> <li>Econ power supply unit</li> <li>Pressure cell PCB</li> <li>Duct restrictor device</li> </ul>	0 – 10 Vdc volumetric output based on duct volume measurement
Volume	<ul style="list-style-type: none"> <li>Econ power supply unit</li> <li>Sash position sensor</li> </ul>	0 – 10 Vdc volumetric output based on sash position and face velocity calculation
Face Velocity	<ul style="list-style-type: none"> <li>Econ power supply unit</li> </ul>	0 – 10 Vdc face velocity retransmission output, 0-10Vdc / 0-1.00m/sec (200fpm) e.g. 0.50m/sec = 5Vdc

### 8.5.1 Bleed Damper

The bleed damper function is used to operate a secondary output based on the Econ Output 1 voltage. It can be scaled and offset to give the required output direction and range. Examples are using the second output as a Fresh Air or Room Air Bleed control voltage signal.

To access the ECON Configure Menu, navigate to **Main Menu > Set up Monitor > Configure > Econ Config**.

Press the ↓ button to scroll down the menu list and press **Mute** to select the required option.

*Note: The Configure menu is password protected. The default password is 0 0 0 0.*

*Note: The Monitor Set up Menu also includes Calibration and Password sub-menus which are used by engineers to set up the system. If you enter any of the Monitor Set up sub-menus by accident, press the ↑ and ↓ arrows together when the password is requested to return to the Monitor Set up menu.*

1. Select **Output Type** from the Econ Configure menu and press **Mute** to continue.

2. Select **Valve** and press **Mute** to continue. This bases the Econ output 1 on the damper position so that the behaviour of both outputs is the same.
3. Select **Done** and press **Mute**.
4. Select **Dual Output**, followed by **Bleed Damper**. Press **Mute**.
5. Use the ↑ and ↓ arrows to select the Bleed Damper parameter and press **Mute**. A sub-menu for the Bleed Damper settings will be displayed:
  - Max Output: Sets the maximum output voltage in Auto control.
  - Min Output: Sets the minimum output voltage in Auto control.
  - Man / Auto: Sets a manual fixed output or selects calibration for Auto control.
6. Select **Man/Auto**, then **Manual** and press **Mute**.
7. Use the ↑ and ↓ arrows to adjust the manual output so that the bleed or room air damper is fully closed. Press **Mute**, select **Done** and press **Mute** again. This closes the secondary output so that the Econ output can be set up and calibrated (section 7.1).

When the airflow sensor is calibrated and the Econ control set up and placed in Auto control, calibrate the bleed damper output as follows:

1. Navigate to **Main Menu > Set up Monitor > Configure**.  
*Note: The Configure menu is password protected. The default password is 0 0 0 0.*
2. Use the ↑ and ↓ arrows to select **Bleed Damper** and press **Mute**. The Bleed Damper sub-menu displays.
3. Select **Man/Auto**, then **Automatic** and press **Mute**.
4. Follow the on-screen instructions to move the sash to the first position (normal working height, approximately 500 mm).
5. Use the ↑ and ↓ arrows to adjust the output % shown on screen to drive Output 2 to the required position, e.g. 0% fully closed. Press **Mute**.
6. Follow the on-screen instructions to move the sash to the second position (sash closed position, approximately 100 mm).
7. Use the ↑ and ↓ arrows to adjust the output % shown on screen to drive Output 2 to the required position, e.g. 100% fully open. Press **Mute**.

Select **Done**, followed by **Run**.

This sets the output so Econ Output 2 is 0% when the sash is at 500 mm and 100% when the sash is closed.

*Note: If the output needs to be reversed, enter 100% for the first calibration point and 0% for the second calibration point during the Auto setting calibration.*

If the output needs to be trimmed or limited, the Max and Min output parameters in the Bleed Damper sub-menu can be adjusted without having to recalibrate the Auto setting:

- **Min Output:** Adjust the minimum output voltage in %. If the Econ Output 1 is set to 2 – 10V, then 0% = 2V, 50% = 6V and 100% = 10V.
- **Max Output:** Adjust the maximum output voltage in %. If the Econ Output 1 is set to 2 – 10V, then 0% = 2V, 50% = 6V and 100% = 10V.

The bleed damper output is 0 – 10V and does not consider the Econ Low Limit and Output range values. If the Dual Output needs to be 2 – 10V, set the Min Output to 20%.

*Note: Econ Output 1 is active while the Bleed Damper Auto calibration menu is in use, so wait a few seconds for the damper to settle once the sash has been moved to enter the first and second calibration values.*

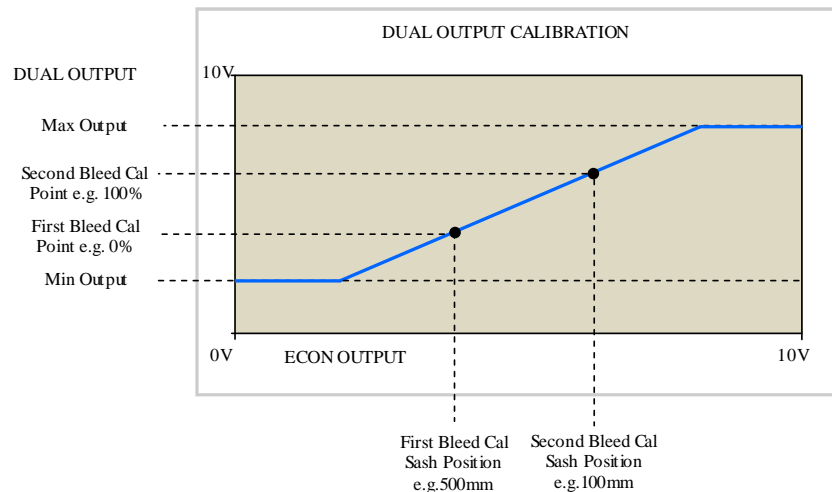

*Figure 67: Dual Output Calibration to give Direct Output (same as Econ output 1 direction)*

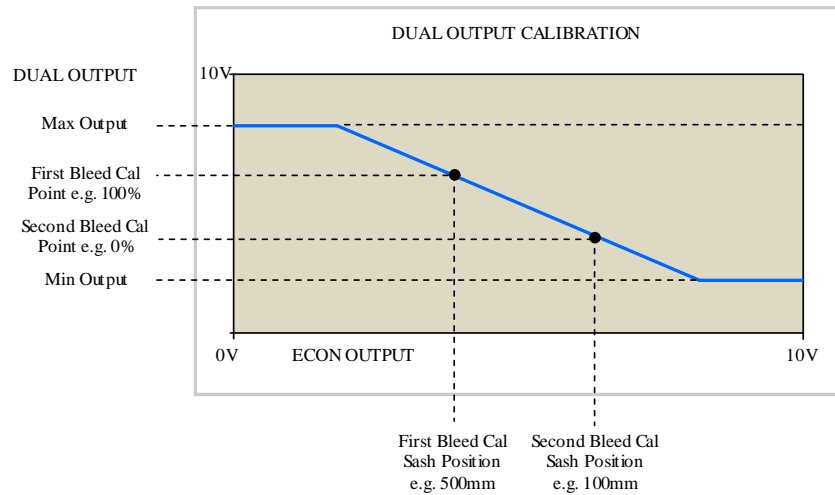

Figure 68: Dual Output Calibration to give Reverse Output (opposite to Econ output 1 direction)

### 8.5.2 Volume pressure

The Volume Pressure function is used to provide a volumetric 0-10 Vdc output relative to the fume cupboard extract volume. The controller power supply is fitted with a pressure cell PCB and connects to a bell mouth venturi type restrictor in the duct. The restrictor can be provided as a separate item or built into the Econ damper section.

3<sup>rd</sup> party restrictor devices or orifice plates can also be used with the pressure cell PCB.

The volumetric output is provided as an analogue 0-10 Vdc signal on Econ Output 2 and is also available on the RS485 comms output.

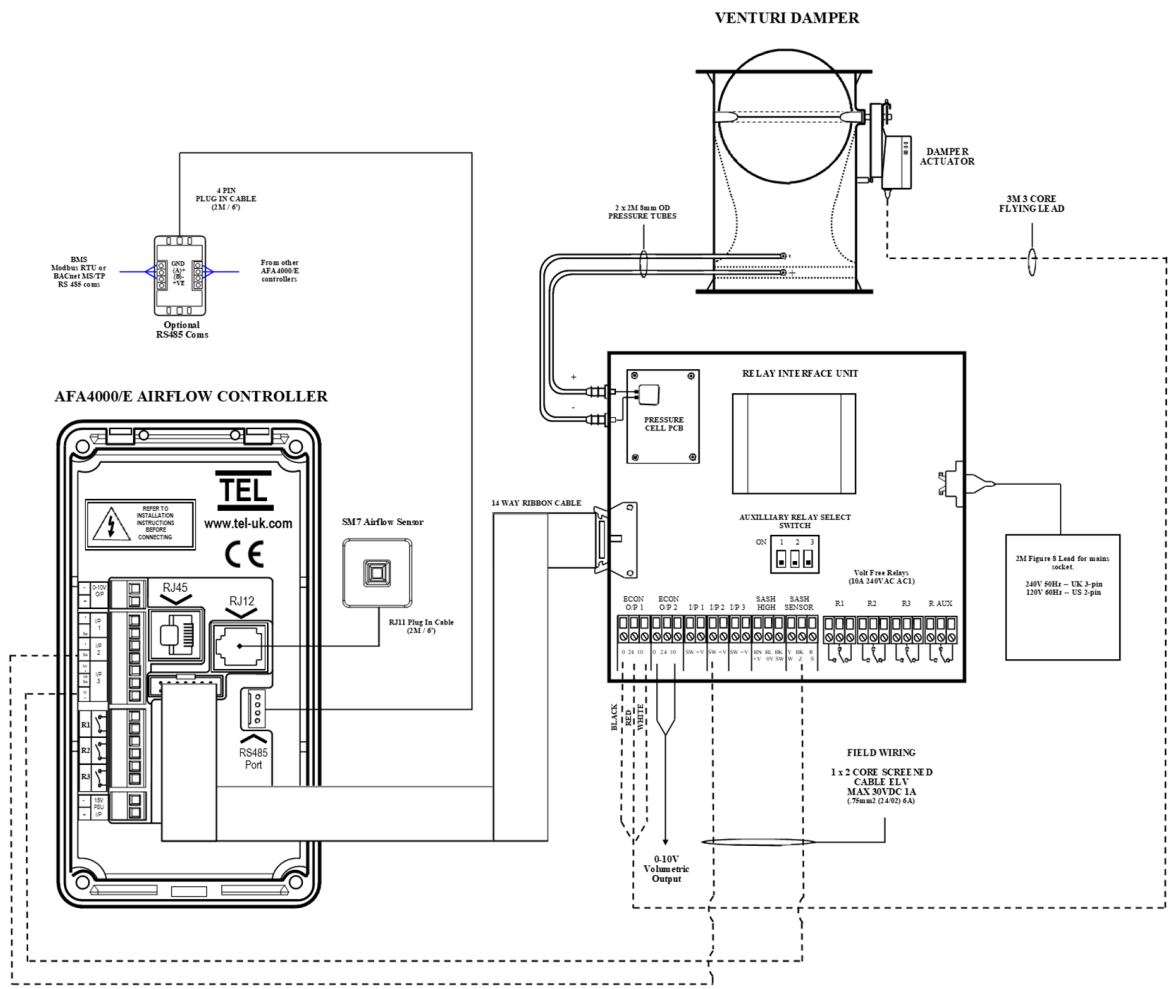

Figure 69: Connection diagram – Standard fume cupboard

A second pressure cell and Venturi damper can be used if the fume cupboard is very wide and has 2 duct connections to the main duct header.

The AFA4000 controller will add the 2 volumes together to give a single total volume output.

3<sup>rd</sup> party restrictor devices or orifice plates can also be used with the pressure cell PCB.

The volumetric output is provided as an analogue 0-10 Vdc signal on Econ Output 2 and is also available on the RS485 comms output.

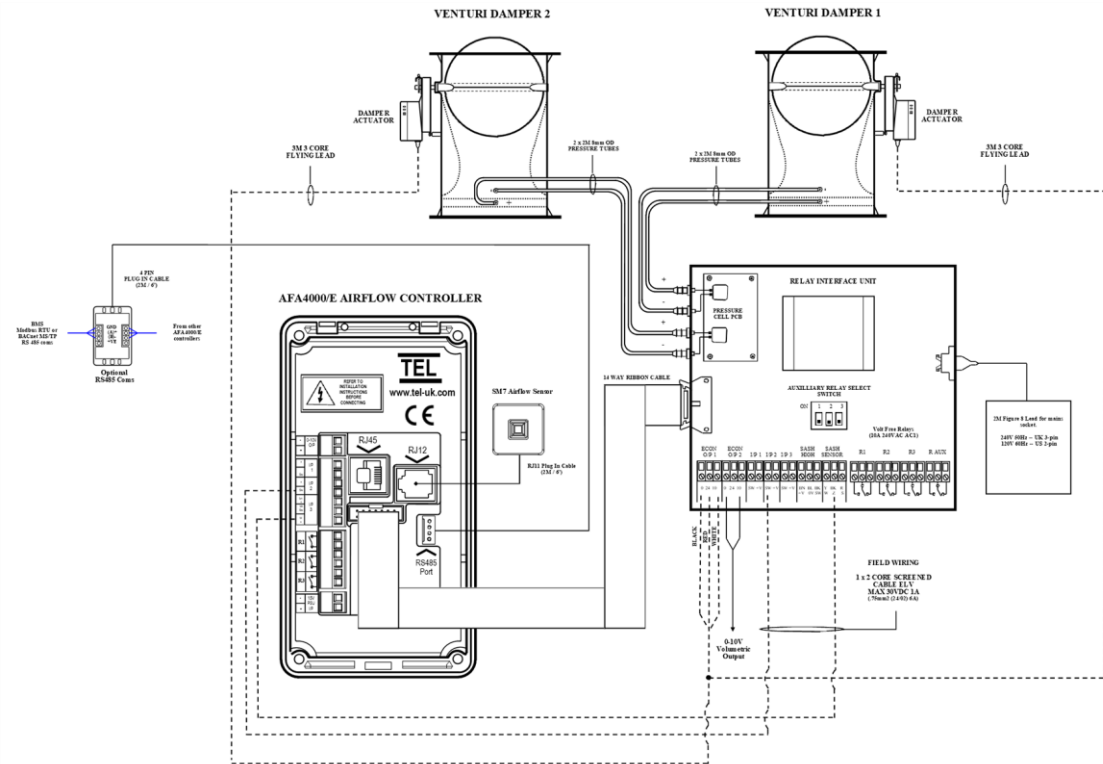

Figure 70: Connection diagram – Wide fume cupboard

To set up the Volume Pressure output using the pushbutton menus:

1. Navigate to **Main Menu > Set up Monitor > Configure**.

*Note: The Configure menu is password protected. The default password is 0 0 0 0.*

Press the ↑ and ↓ arrows to scroll through the menu list and press **Mute** to select the required option.

2. Select **Input 2 > Analogue > Volume Pressure**.
3. Select **Dual Output > Volume Pressure**.
4. Use the ↑ and ↓ arrows to select the **Volume Pressure** parameter and press **Mute**. The Volume Pressure settings sub-menu displays:

Parameter	Description	Range
Input range	Input range from pressure cell	0 - 50, 100, 250, 500
Output range	Volumetric Output volume range for 0 - 10 Vdc	0 - 1000 l/sec
Input filter	Time average filter	1 to 100 seconds



K factor	Constant for venturi device	00.00 to 100.00
F factor	Offset for fume cupboard leakage	100 to 200%
Air density	Air density constant	1.0 to 1.2 kg/m <sup>3</sup>

5. Select **Input Range**, then use the ↑ and ↓ arrows to adjust the value to match the settings on the pressure cell PCB. Press **Mute**. (Default value: 0 – 50).
6. Select **Output Range**, then use the ↑ and ↓ arrows to adjust the value to match the fume cupboard volume range. Press **Mute**. (Default value: 0 – 1000). For example, changing to 500 l/sec gives 0 – 10V over 0 – 500 l/sec (10 V = 500 l/sec).
7. Select **Input Filter**, then use the ↑ and ↓ arrows to adjust the value so that the volumetric output is stable. Press **Mute**. (Default value: 1 second).

*Note: The filter gives a rolling average over time to compensate for turbulent duct readings.*

8. Select **K Factor**, then use the ↑ and ↓ arrows to adjust the value so that the correct constant correction value is displayed. (Default value: 45.80 for TEL device).
9. Select **F Factor**, then use the ↑ and ↓ arrows to adjust the value so that the correct leakage correction value is displayed. (Default value: 100%).

*Note: The volume is measured in the duct and may not represent the face velocity calculated volume due to leakage, using the F factor compensation the controller will display relative fume cupboard volume, for example, set to 110% for 10% leakage.*

10. Select **Air Density**, then use the ↑ and ↓ arrows to adjust the value so that the correct value is displayed. (Default value: 1.2 kg/m<sup>3</sup>). Select **Done** and **Run**. For example, change to 1.0 kg/m<sup>3</sup> if a 3<sup>rd</sup> party restrictor is used that doesn't consider air density.

### 8.5.3 Pressure Cell PCB settings and calibration

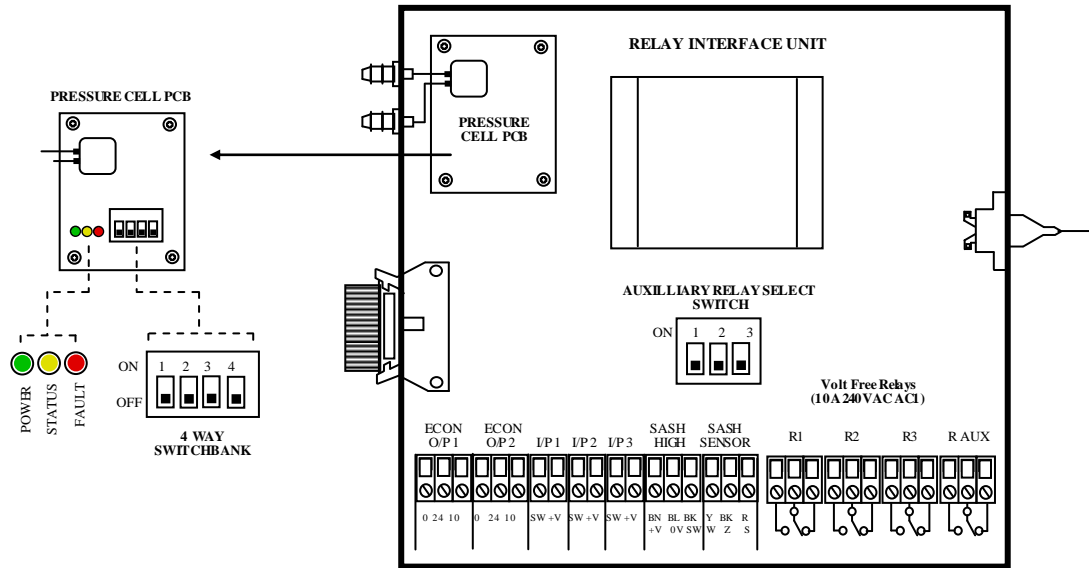

Figure 71: Pressure cell PCB location

The pressure cell PCB has a 4-way switch bank and 3 LEDs. (Bold = default)

SW1	SW2	SW3	SW4	Mode	Range
<b>OFF</b>	<b>OFF</b>				<b>5 V @ 100 Pa, 10 V @ 400 Pa</b>
ON	OFF		<b>TARE</b>	Output proportional to Volume	5 V @ 250 Pa, 10 V @ 1000 Pa
OFF	ON	<b>OFF</b>			5 V @ 500 Pa, 10 V @ 2000 Pa
ON	ON				5 V @ 1000 Pa, 10 V @ 4000 Pa
OFF	OFF				5 V @ 100 Pa, 10 V @ 200 Pa
ON	OFF		<b>TARE</b>	Output proportional to Pressure	5 V @ 250 Pa, 10 V @ 500 Pa
OFF	ON	ON			5 V @ 500 Pa, 10 V @ 1000 Pa
ON	ON				5 V @ 1000 Pa, 10 V @ 2000 Pa
OFF/ ON					



SW1	SW2	SW3	SW4	Mode	Range
-----	-----	-----	-----	------	-------

- SW1 & SW2 are used to select the pressure range.
- SW3 is used to select Volume or Pressure output.
- SW4 is used to Tare (Zero) the pressure cell.
- The output proportional to pressure setting is used for testing purposes and not for operational use (SW3 should be set to OFF).

### 8.5.3.1 Calibration (Tare)

1. With the cover on the enclosure, power up the Econ power supply and wait 5 minutes for the pressure cell to stabilise.
2. Make sure the extract fan is switched off.
3. The LEDs will down the following:

Mode	Power LED	Status LED	Fault LED	Vout1	Vout2
Sensor Fault	ON	OFF	ON	10V	10V
Requires Calibration	ON	FLASH	FLASH	10V	10V
Calibration in Progress	ON	FLASH	OFF	0V	0V
Warming up period	FLASH	OFF	OFF	0V	0V
OK	ON	ON	OFF	P/Vol OP	P/Vol OP

4. Set SW4 to the ON position, the Status LED will flash for 5 seconds whilst the cell output is zeroed and the Fault LED will go solid.
5. Once the calibration is complete the Status LED will go solid.
6. Set SW4 to the OFF position.
7. The Power and Status LED's should be ON and the Fault LED should be OFF (OK).

*Note: For best accuracy, the pressure cell calibration is required to compensate for altitude, orientation of power supply box etc.*

### 8.5.3.2 Testing

When the cell has been calibrated, and the extract fan is running, the measured volume will display in the Diagnostics Menu I/O Status – Sensor Data screen (section 13.2).

### 8.5.4 Volume (sash position sensor)

The Volume function is used to provide a volumetric 0-10 Vdc output relative to the fume cupboard extract volume using a sash position sensor. It can only be used on a bench-type fume cupboard with a single vertical sash.

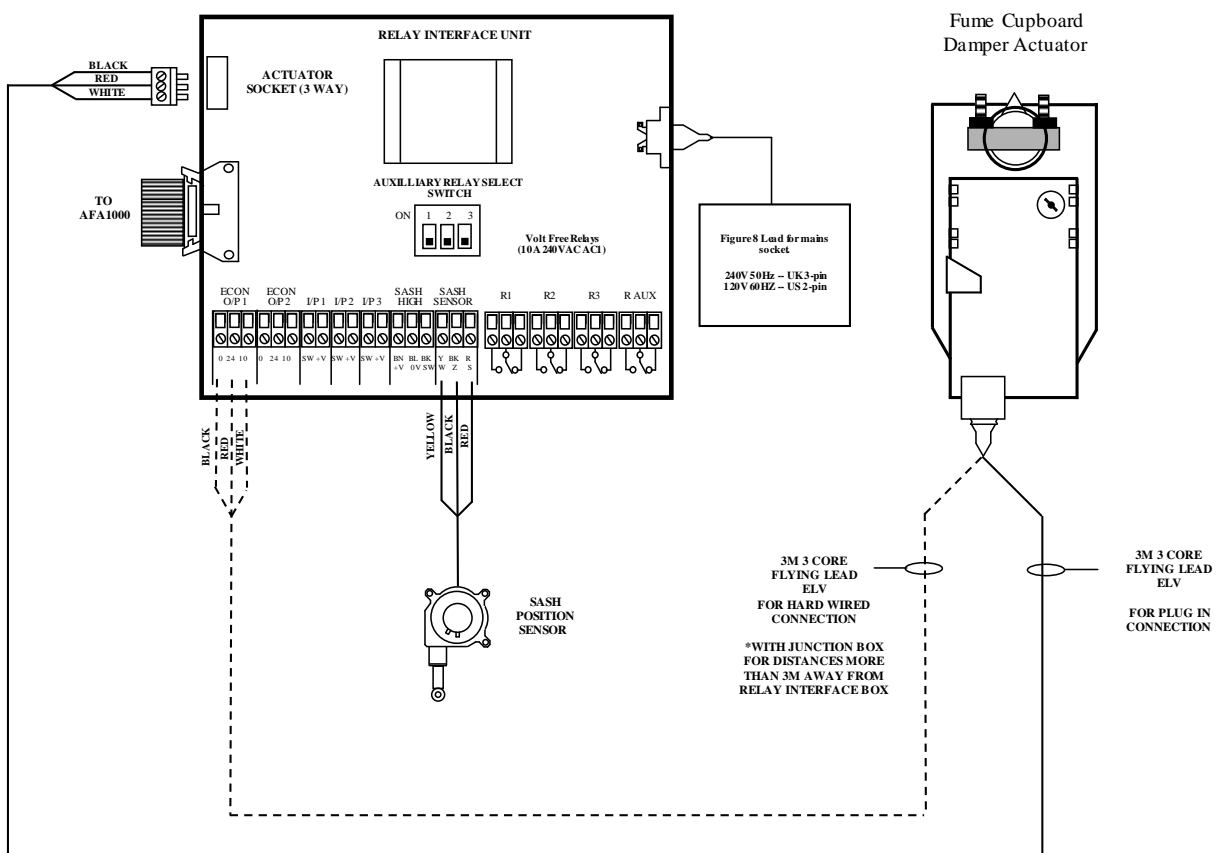

Figure 72: Typical connection diagram

The sash position sensor is fitted with a mounting bracket that can be fitted in four different orientations to enable the sensor draw wire to be correctly aligned.

1. Offer up the sensor to determine the best fixing position on the fume cupboard framework. For best results, the sensor draw wire should run straight out of the sensor housing, in line with the cable housing extension. In cases where the wire has run at an angle to the sensor, make sure the angle is as small as possible so the wire does not rub on any part of the sensor body including the cable housing extension
2. Mark the fixing holes in the framework and attach the sensor. The fixing bracket has two 0.37 mm (0.015") diameter fixing holes.

*Note: Make sure the sensor is in a suitable position so that the draw wire does not over extend. The sensor draw wire maximum stroke is 1270 mm (50").*

3. Attach the draw wire to either:

- The sash, using a suitably sized screw. The draw wire has a 9.53 mm (0.38") diameter fixing ring with a 4.85 mm (0.18") diameter fixing hole in its centre.
- The sash cable, using a cable tie, ensuring that the fixing ring does not run over pulleys etc.
- The counterweight, using a cable tie.

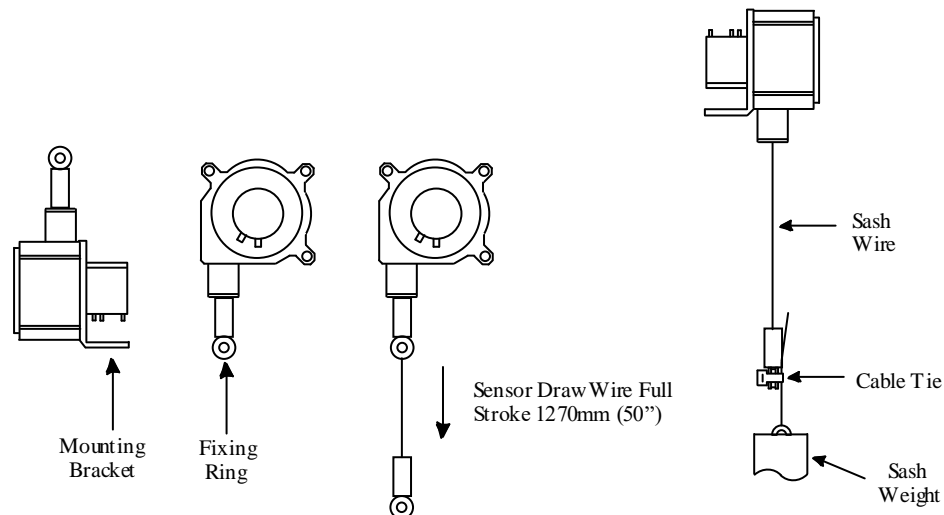

4. Once the sensor is fitted, manually move the sash to ensure the sensor runs freely and does not snag.

To set up the Volume output using the pushbutton menus:

1. Navigate to **Main Menu > Set up Monitor > Configure.**

*Note: The Configure menu is password protected. The default password is 0 0 0 0.*

Press the ↑ and ↓ arrows to scroll through the menu list and press **Mute** to select the required option.

2. Select **Input 2 > Analogue > Sash Position.**

3. Select **Dual Output > Volume.**

4. Use the ↑ and ↓ arrows to select the **Volume Output** parameter and press **Mute**. The Volume Output settings sub-menu displays:

Parameter	Description	Range
Sash Width	Enter the internal Fume Cupboard width	0-7000 mm
Sash Gap	Volumetric Output volume range for 0-10 Vdc	0-1000 mm
Max Volume	Enter the maximum fume cupboard volume or required range	1 to 1000 l/sec

5. Select **Sash Width**, then use the ↑ and ↓ arrows to enter the measured internal width. Press **Mute**. (Default value: 0 – 1200 mm).
6. Select **Sash Gap**, then use the ↑ and ↓ arrows to enter the measured gap value. Press **Mute**. (Default value: 25 mm). (for example, the gap between the sash and soffit panel (e.g. 25 mm)).
7. Select **Max Volume**, then use the ↑ and ↓ arrows to adjust the value so the volumetric output range is equal to the required fume cupboard volume range. Press **Mute**. (Default value: 1000 l/sec). Select **Done** and **Run**. For example, setting the Max Volume 1000 l/sec will give 10 Vdc @ 10,000 l/sec, setting the Max Volume to 500 l/sec will give 10 Vdc @ 500 l/sec etc.

#### 8.5.4.1 Calibration

Once the settings described above have been entered, the sash position sensor must be calibrated:

1. Navigate to **Main Menu > Set up Monitor > Calibration**.  
*Note: The Calibration menu is password protected. The default password is 0 0 0 0.*
2. Select **Sash Position Sensor**.
3. Follow the on-screen instructions to move the sash to the first position (normal working height, approximately 500 mm).
4. Use the ↑ and ↓ arrows to enter the sash height. Press **Mute**.
5. Follow the on-screen instructions to lower the sash to the second position (approximately half way, 250 mm).
6. Use the ↑ and ↓ arrows to enter the sash height. Press **Mute**.  
Select **Done**, followed by **Run**.

#### 8.5.4.2 Testing

When the sash position sensor has been calibrated, and the extract fan is running, the measured volume will display in the Diagnostics Menu I/O Status – Sensor Data screen (section 13.2).

## 8.6 *Auto Sash Controller system menus*

This section refers to when the Auto Sash Controller is used without the AF4000/E/AS Airflow Monitor.

The *System Menus* allow the user to define parameters affecting the operation of the Auto Sash Controller and associated systems.

The overall structure of the System Menus and routes to access individual menu items are illustrated in the flow chart on the next page:

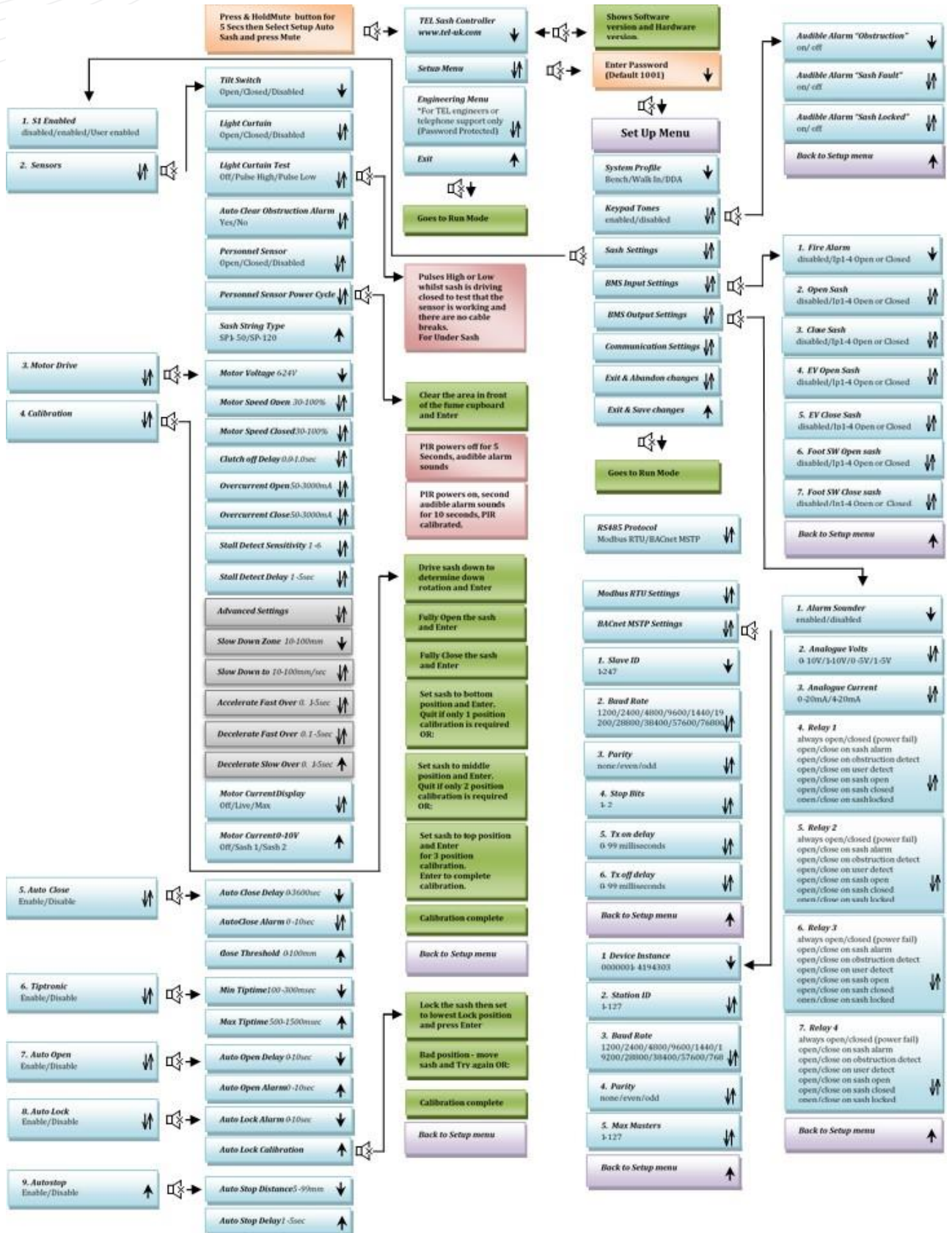

### 8.6.1 *Accessing System Menus*

To access the *System Menus*, press and hold the **Enter** button for approximately 5 seconds or until the *Main/Setup menu* is displayed.

1. Navigate the *Main/Setup menu* using the ↑/↓ buttons, select the required menu and press **Enter**.
2. Navigate the chosen menu using ↑/↓ buttons.
3. Select from the following *System Menus*:
  - Keypad Tones
  - Sash 1 Settings
  - BMS Input Settings
  - BMS Output Settings
4. Select menu entry and press **Enter**.
5. Select a menu entry value / parameter using ↑ / ↓ buttons to display the required value/parameter, press **Enter**.
6. Press **Cancel** to exit the menu entry and return to the menu.
7. To return to the *Main / Setup menu* use ↑ / ↓ buttons and select *Back to Setup Menu*, press **Enter**.
8. Using ↑/↓ buttons select one of:
  - Exit and Abandon Changes
  - Exit and Save Changes

## 8.6.2 Navigating the system menus

### 8.6.2.1 Keypad tones

Menu item	Option	Instructions
Keypad tones		Enable or disable the keypad sounding when a key is pressed.

### 8.6.2.2 Sash 1 settings menu

Menu item	Option	Instructions
Sash 1 settings	Enabled	Choose the setting to permanently enable/disable the Auto Sash Controller motor drive: <ul style="list-style-type: none"> <li>• No to disable the drive.</li> <li>• Yes to enable the drive.</li> </ul>
Sensors	Tilt Switch	Set the input activation for the tilt switch: <ul style="list-style-type: none"> <li>• Normally Open (N/O) Contact</li> <li>• Normally Closed (N/C) Contact</li> </ul> Disabled
	Light Curtain	Enable or disable the Light Curtain: <ul style="list-style-type: none"> <li>• Normally Open (N/O) Contact</li> <li>• Normally Closed (N/C) Contact</li> </ul> Disable
	Light Curtain Test	Enable or disable Light Curtain Test: <ul style="list-style-type: none"> <li>• Pulse High</li> <li>• Pulse Low</li> </ul> Off
	Auto Clear Obstruction Alarm	Enable or disable Auto Clear Obstruction Alarm: <ul style="list-style-type: none"> <li>• Yes</li> <li>• No</li> </ul>



Menu item	Option	Instructions
Sensors (cont.)	Personnel (Sensor)	Set the input activation for the personnel sensor: <ul style="list-style-type: none"> <li>• Normally Open (N/O) Contact</li> <li>• Normally Closed (N/C) Contact</li> </ul> Disabled
	Sash String Type	Set the input activation for the sash string: <ul style="list-style-type: none"> <li>• SP1-50</li> <li>• SP-120</li> </ul>
Motor Drive	Motor Voltage	Set the motor voltage: 6-24V
	Motor Speed Open	Set the motor speed: 30-100%
	Motor Speed Closed	Set the motor speed: 30-100%
	Clutch Off Delay	Set the delay time: 0.0-1.00sec
	Overcurrent Open	Set the overcurrent level: 50-3000mA
	Overcurrent Close	Set the overcurrent level: 50-3000mA
	Stall Detect Sensitivity	Set the sensitivity level: 1-6
	Stall Detect Delay	Set the delay time: 1-5 Seconds

Menu item	Option	Instructions
Motor Drive (cont.)	Motor Current Display	Set the required current display: <ul style="list-style-type: none"> <li>• Live</li> <li>• Max</li> <li>Off</li> </ul>
	Motor Current 0-10V	Set the required output: <ul style="list-style-type: none"> <li>• Sash 1</li> <li>• Sash 2</li> <li>Off</li> </ul>
Calibration		Calibrates sash position sensor and motor direction. See section 7.4.2
Auto Close	Enable / Disable	Set the required action: <ul style="list-style-type: none"> <li>• Enable</li> <li>• Disable</li> </ul>
	Auto Close Delay	Set the delay time: 1-3600 Seconds
	Auto Close Alarm	Set the delay time: 0-10 Seconds
Tiptronic	Enable / Disable	Set the required action: <ul style="list-style-type: none"> <li>• Enable</li> <li>• Disable</li> </ul>
	Min Tiptime	Set the min tip time: 100-300msec
	Max Tiptime	Set the max tip time: 500-1500msec
Auto Open	Enable / Disable	Set the required action: <ul style="list-style-type: none"> <li>• Enable</li> <li>• Disable</li> </ul>

Menu item	Option	Instructions
	Auto Open Delay	Set the delay time: 0-10 Seconds
Auto Open (cont.)	Auto Open Alarm	Set the delay time: 0-10 Seconds
Auto Lock	Enable / Disable	Set the required action: <ul style="list-style-type: none"> <li>• Enable</li> <li>• Disable</li> </ul>
	Auto Lock Alarm	Set the alarm delay time: 0-10 Seconds
	Auto Lock Calibration	Calibrate the Lock position
Auto Stop	Enable / Disable	Set the required action: <ul style="list-style-type: none"> <li>• Enable</li> <li>• Disable</li> </ul>
	Auto Stop Distance	Set the lock distance: 5-99mm
	Auto Stop Delay	Set the delay time: 1-5 Seconds

### 8.6.2.3 BMS input settings

Menu item	Option	Instructions
BMS Input Settings	Fire Alarm	Set the Fire Alarm BMS input: <ul style="list-style-type: none"> <li>• Disabled</li> <li>• Input 1 – 4 open</li> <li>• Input 1 – 4 closed</li> </ul>
	Open Sash	Set the Open Sash BMS input: <ul style="list-style-type: none"> <li>• Disabled</li> <li>• Input 1 – 4 open</li> <li>• Input 1 – 4 closed</li> </ul>

Menu item	Option	Instructions
	Close Sash	Set the Close Sash BMS input: <ul style="list-style-type: none"> <li>• Disabled</li> <li>• Input 1 – 4 open</li> <li>• Input 1 – 4 closed</li> </ul>
	EV Open Sash	Set the EV Open Sash BMS input: <ul style="list-style-type: none"> <li>• Disabled</li> <li>• Input 1 – 4 open</li> <li>• Input 1 – 4 closed</li> </ul>
BMS Input Settings (cont.)	EV Close Sash	Set the EV Close Sash BMS input: <ul style="list-style-type: none"> <li>• Disabled</li> <li>• Input 1 – 4 open</li> <li>• Input 1 – 4 closed</li> </ul>
	Foot SW Open	Set the Foot SW Open BMS input: <ul style="list-style-type: none"> <li>• Disabled</li> <li>• Input 1 – 4 open</li> <li>• Input 1 – 4 closed</li> </ul>
	Foot SW Closed	Set the Foot SW Close BMS input: <ul style="list-style-type: none"> <li>• Disabled</li> <li>• Input 1 – 4 open</li> <li>• Input 1 – 4 closed</li> </ul>

#### 8.6.2.4 BMS output settings

Menu item	Option	Instructions
BMS Output Settings	Alarm Sounder	Enable / disable the remote alarm sounder.
	Analog Volts	Select the required analogue output voltage for sash position indication: <ul style="list-style-type: none"> <li>• 0 – 10V</li> <li>• 1 – 10V</li> <li>• 0 – 5V</li> <li>• 1 – 5V</li> </ul>
	Analog Current	Select the required analogue output current for sash position indication: <ul style="list-style-type: none"> <li>• 0 – 20mA</li> <li>• 4 – 20mA</li> </ul>
	Relays 1 – 4 (RLY1, RLY2, RLY3, RLY4)	Select the required settings for each of the four relays: <ul style="list-style-type: none"> <li>• Always Open</li> <li>• Always Closed</li> <li>• Open on Sash Alarm</li> <li>• Close on Sash Alarm</li> <li>• Open on Obstruction Detected</li> <li>• Close on Obstruction Detected</li> <li>• Open on User Detected</li> <li>• Close on User Detected</li> <li>• Open on Sash Open</li> <li>• Close on Sash Open</li> <li>• Open on Sash Locked</li> <li>• Close on Sash Locked</li> </ul>

## 9. Auxiliary features and connections

### 9.1 Dual set point (occupancy) operation

The Dual Set Point function operates with a PIR occupancy sensor, enabling the controller to operate to a lower Econ control velocity set point and reduced alarm points when the fume cupboard is unoccupied.

When the dual set point function is active, the controller displays *High Set Point*, *Low Set Point* or *Manual* above the output status bar graph, indicating the current occupancy condition.

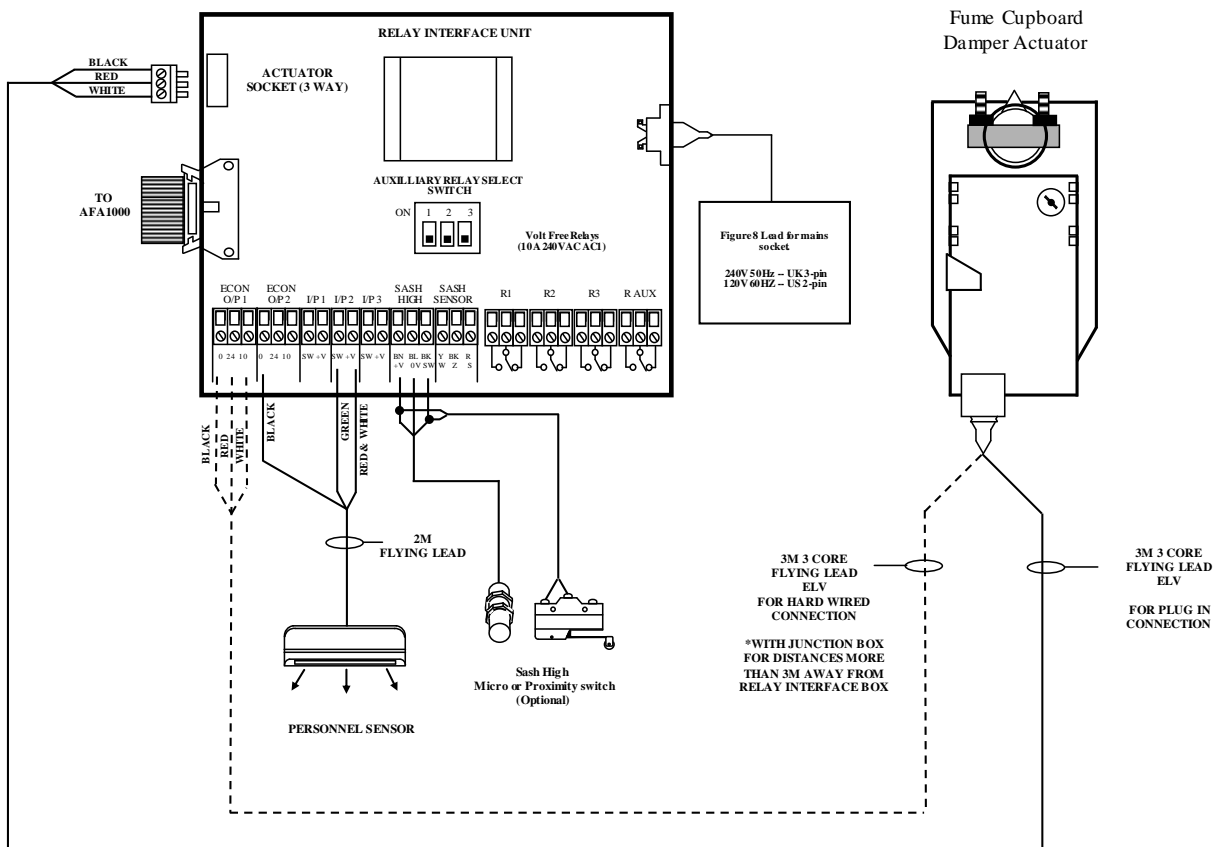

Figure 73: Typical connection diagram

Press the ↑ and ↓ arrows to scroll through the menu list and press **Mute** to select the required option.



Setting up the dual set point:

1. From the *Requires set up* screen, press **Mute**, or from the *Run Screen* press and hold the **Mute** button for 5 seconds until the *Main Menu* is displayed.
2. Select **Set Up Monitor > Configure**.
3. Enter the password (the factory default password is 0-0-0-0) and press **Mute** to continue.
4. Select **Input 2 > Closed Contact > Pers. Sensor**.
5. Select **Econ Config > High Set Point**, then use the ↑ / ↓ buttons to adjust the value to the required High (Occupied) set point.
6. Select **Econ Config > Low Set Point**, then use the ↑ / ↓ buttons to adjust the value to the required Low (Unoccupied) set point and set the required activation delay time.

*Note: The activation delay time is a delay period that activates when the fume cupboard is unoccupied, before the controller changes to low set point operation. This allows the user to briefly return to the fume cupboard without the controller reducing the setpoint (0 – 300 seconds time range).*

7. Select **Cal Config Menu > Low Air Alarm**, then use the ↑ / ↓ buttons to adjust the value to the required (occupied) alarm point.
8. Select **Warning Air Alarm**, then use the ↑ / ↓ buttons to adjust the value to the required (occupied) alarm point.
9. Select **Reduced Low Air Alarm**, then use the ↑ / ↓ buttons to adjust the value to the required (unoccupied) alarm point.
10. Select **Reduced Warning**, then use the ↑ / ↓ buttons to adjust the value to the required (unoccupied) alarm point.
11. Select **Done** and **Run**.

*Note: The typical alarm points are:*

Status	Set Point Value	Low Air Alarm	Warning Air Alarm	Reduced Low Air Alarm	Reduced Warning Air Alarm
High set point	0.50 m/sec	0.40 m/sec (80%)	0.45 m/sec (90%)		
Low set point	0.30 m/sec			0.24 m/sec (80%)	0.27 m/sec (80%)

### **9.1.1** *PIR sensor*

The Personnel Sensor is a Passive Infra-Red (PIR) occupancy detector that detects the presence or absence of the fume cupboard operator. It is used to change the control set point whenever the fume cupboard is unoccupied.

On power up, the Personnel Sensor detects the reflection characteristics of the environment within its field of view and stores this information as reference background data. The sensor then re-detects the background every three minutes, so that if a stationary object, such as a stool, is left in the field it will become part of the background and ignored by the sensor.

Refer to the manufacturer's data sheet or separate PIR specification sheet for installation details.

## **9.2** *Optional input function - temperature sensor*

The AFA4000/E can be fitted with a temperature sensor. The sensor displays the fume cupboard temperature and can produce high and low temperature alarms. The temperature display can be hidden or shown with the airflow velocity display.

High and Low temperature alarms can be set with relay outputs.



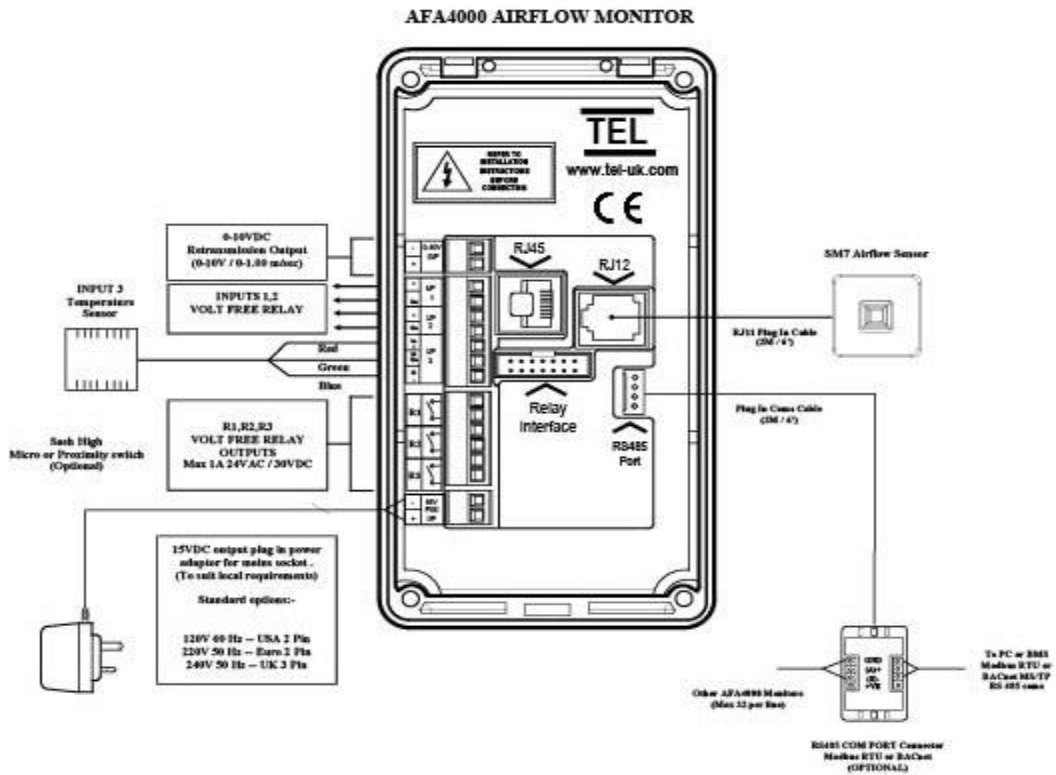

*Figure 74: Typical connection diagram*

Press the ↑ and ↓ arrows to scroll through the menu list and press **Mute** to select the required option.

Setting up the temperature input:

1. From the *Requires set up* screen, press **Mute**, or from the *Run Screen* press and hold the **Mute** button for 5 seconds until the *Main Menu* is displayed.
2. Select **Set Up Monitor > Configure**.
3. Enter the password (the factory default password is 0-0-0-0) and press **Mute** to continue.
4. Select **Input 3 > Analog > Temperature**. The Temperature sub-menu displays:



	<b>Parameter</b>	<b>Description</b>	<b>Range</b>
A	Temperature Units	Display units	°C or °F
B	Low Temperature Alarm	Sets the Low Temperature Alarm point	0.0 to High Alarm value
C	High Temperature Alarm	Sets the High Temperature Alarm point	100.0 to Low Alarm value
D	Show Temperature	Turns the temperature display On / Off	Yes / No
E	Offset	Allows the measured value to be offset	-5.0 °C to +5.0 °C

*Note: The temperature sensor is accurate to 0.5 °C. The offset parameter can be used, if the displayed value needs to be changed to match a 3rd party instrument or other equipment.*

5. Select **Temperature Units > Centigrade / Fahrenheit.**
6. Select **Low Temperature Alarm**, then use the ↑ / ↓ buttons to set the alarm point.
7. Select **High Temperature Alarm**, then use the ↑ / ↓ buttons to set alarm point.
8. Select **Show Temperature**, then select **Enabled** or **Not Enabled**
9. Select **Offset**, and then select **Done**.
10. In the **Monitor Config Menu**, select **Low Temperature Relay**, and use the ↑ / ↓ buttons to set the relay output.
11. In the **Monitor Config Menu**, select **High Temperature Relay**, and use the ↑ / ↓ buttons to set the relay output.
12. Select **Done > Run**.

### 9.2.1 Testing

Once the temperature sensor function has been configured the temperature will display in the diagnostics menu I/O Status.

The sensor data screen is described in section 13.2.

### 9.3 Optional input function – close sash alarm

A Close Sash alarm informs the user that the fume cupboard sash has been left open. The alarm can be set with a time delay before activation, this allow the user to briefly leave the fume cupboard sash open. The alarm can be set to repeat if the sash is left open for prolonged periods.

The alarm function uses a PIR sensor and uses the sash position sensor to monitor the sash height.

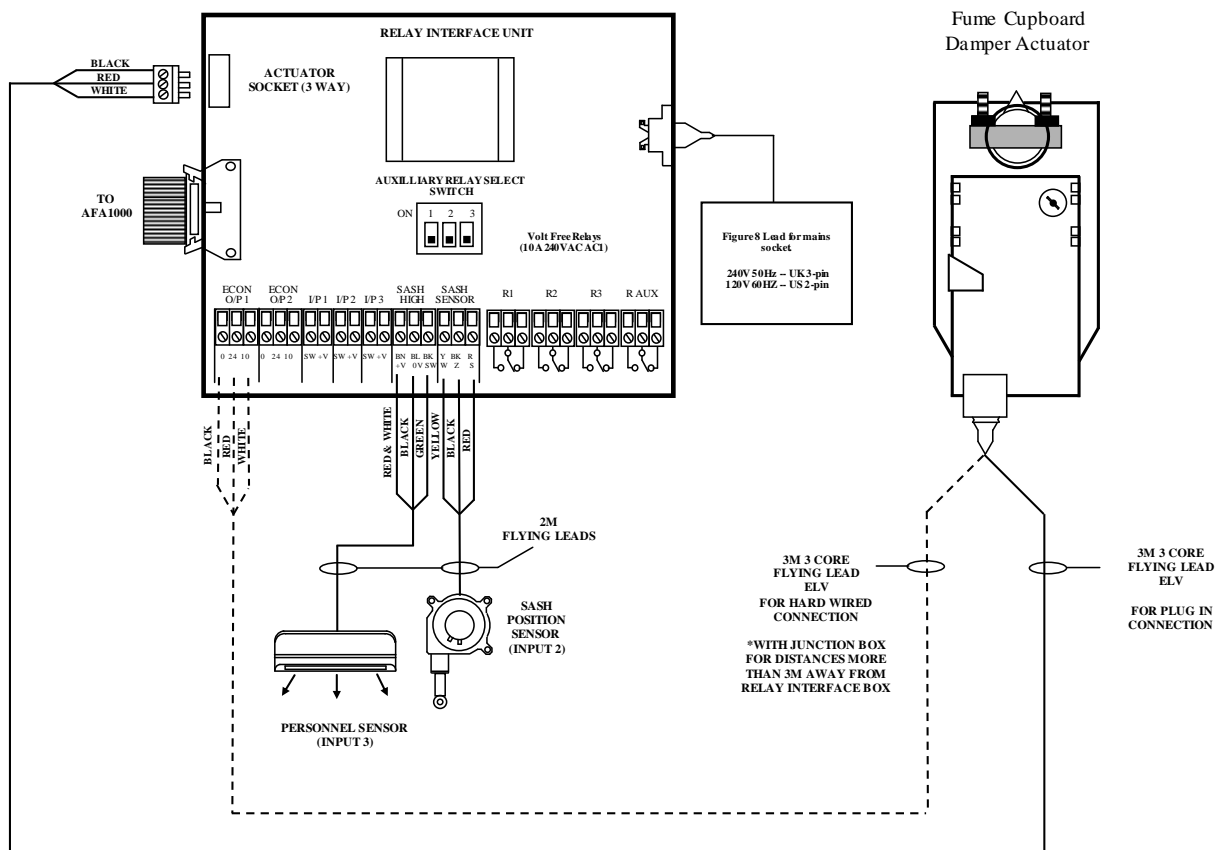

Figure 75: Typical connection diagram with sash position sensor

To Setup the Close Sash Alarm with a sash position sensor:

Press the ↑ and ↓ arrows to scroll through the menu list and press **Mute** to select the required option.

1. From the *Requires set up* screen, press **Mute**, or from the *Run Screen* press and hold the **Mute** button for 5 seconds until the *Main Menu* is displayed.
2. Select **Set Up Monitor > Configure**.
3. Enter the password (the factory default password is 0-0-0-0) and press **Mute** to continue.
4. Select **Input 2 > Analogue > Sash Position**.
5. Select **Input 3 > Closed Contact > Sash Warning**.
6. Select **Sash Closed Input > Sash Position Sensor > Sash Closed Height**.  
*Note: The Sash Closed Height is the height that the sash is considered to be closed, for example 100 mm = sash closed alarm not active when the sash is  $\leq 100$  mm.*
7. Select **Sash Warning Timer > Sash Warning Time Delay**.
8. Use the  $\uparrow / \downarrow$  buttons to set the **Sash Warn Rpt Time** to **Enabled / Disabled**. If set to **Enabled**, use the  $\uparrow / \downarrow$  buttons to set the **Sash Warn Rpt Time**, then **Done**.  
For example: Sash closed switch height set to 100 mm, sash warning delay set to 1 minute, sash warning repeat timer set to 5 minutes. If the sash is  $> 100$  mm, the close sash alarm activates if the fume cupboard is unoccupied for 1 minute. After being muted, the alarm re-sounds after 5 minutes. The alarm resets if the fume cupboard is then occupied or the sash is  $\leq 100$  mm.
9. Select **Set Up Monitor > Calibration**.
10. Enter the password (the factory default password is 0-0-0-0) and press **Mute** to continue.
11. Select **Sash Position Sensor**.
12. Follow the on-screen instructions. Open the sash to the normal working height (e.g. 500 mm), then use the  $\uparrow / \downarrow$  buttons to enter the sash height.
13. Follow the on-screen instructions. Lower the sash to approximately half way (e.g. 250 mm), then use the  $\uparrow / \downarrow$  buttons to enter the sash height.
14. Select **Done** and **Run**.

### 9.3.1 *Testing*

Once the sash position sensor has been configured the sash height will display in the diagnostics menu I/O Status.

The sensor data screen is described in section 13.2.

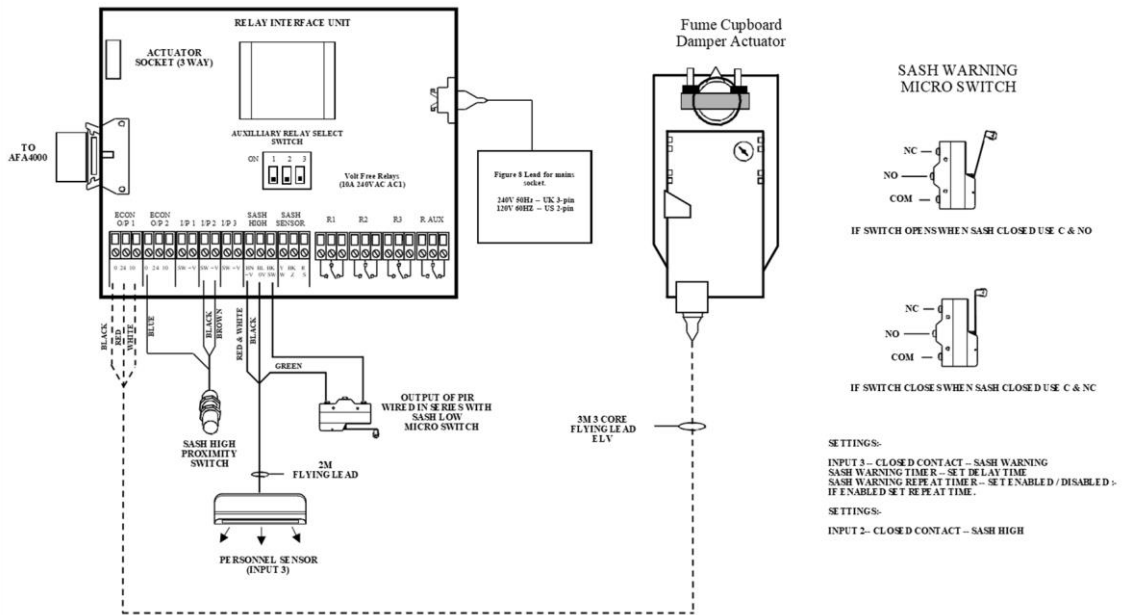

Figure 76: Typical connection diagram with micro-switch

The micro-switch connections will depend on the switch activation. The output of the PIR is wired in series with the switch so the output should be active (switch contact closed) when the sash is open.

Switch Mounting	Switch connections	Notes
A Switch closes when sash is open	C & NO	Refer to the micro-switch for switch connection details.
B Switch closes when sash is closed	C & NC	

To Setup the Close Sash Alarm with a sash micro-switch:

Press the ↑ and ↓ arrows to scroll through the menu list and press **Mute** to select the required option.

1. From the *Requires set up* screen, press **Mute**, or from the *Run Screen* press and hold the **Mute** button for 5 seconds until the *Main Menu* is displayed.
2. Select **Set Up Monitor > Configure**.
3. Enter the password (the factory default password is 0-0-0-0) and press **Mute** to continue.
4. Select **Input 3 > Closed Contact > Sash Warning**.
5. Select **Sash Closed Input > Sash Switch**.

6. Select **Sash Warning Timer > Sash Warning Time Delay.**
7. Use the  $\uparrow$  /  $\downarrow$  buttons to set the **Sash Warn Rpt Time** to **Enabled / Disabled**. If set to **Enabled**, use the  $\uparrow$  /  $\downarrow$  buttons to set the **Sash Warn Rpt Time**, then **Done**.

For example: Sash closed switch height set to 100 mm, sash warning delay set to 1 minute, sash warning repeat timer set to 5 minutes. If the sash is  $> 100$  mm, the close sash alarm activates if the fume cupboard is unoccupied for 1 minute. After being muted, the alarm re-sounds after 5 minutes. The alarm resets if the fume cupboard is then occupied or the sash is  $\leq 100$  mm.

## 9.4 Fail safe damper operation

The Econ power supply is fitted with a super-cap quick-charge fail-safe feature that opens the fume cupboard damper actuator in the event of mains power loss (Econ output 1 only). This feature allows non fail-safe actuators to be fitted to the fume cupboard damper.

Specification	Ratings and requirement for fail-safe feature
Actuator voltage	22-28 Vdc
Actuator torque	Max 4 Nm
Actuator power consumption whilst driving	Max 13W
Butterfly damper max pressure drop across damper	1000 Pa
Multivane damper max pressure drop across damper	500 Pa
<b>Fail-safe operation</b>	
Fail-safe charge time	Max 30 seconds from fully discharged state
Fail-safe operation time	Max 5 seconds @ 0.25 W 24 Vdc for 4 Nm actuator
Charging indication	LED 2 (Green) Dim
Fail-safe active	LED 2 (Green) Bright

*Note: Recommended damper actuator = Belimo LMQ24A-SR-TEL*

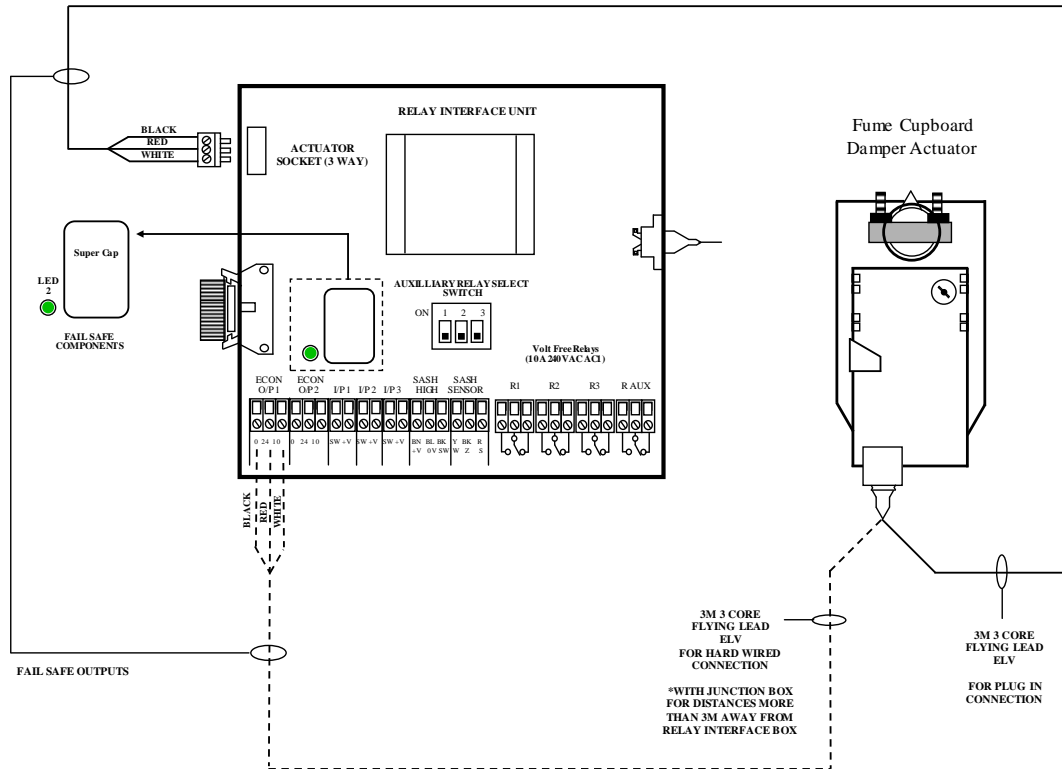

Figure 77: Fail-safe component location and outputs



# 10. RS485 communications output

## 10.1 Overview and connections

The AFA4000 series has onboard RS485 comms with 3 protocols:

Protocol	Description
TEL	Protocols for connections to TEL Configure Manager PC software and room controls include TELBUS & TEL 5000 (AFA5000) and TEL PC (Config)
Modbus	Modbus RTU protocol
BACnet	BACnet MS/TP protocol (To connect to BACnet IP, a 3rd party router is required)

For further technical, compliance and register information, see separate comms registers:

- AFA4000/E Modbus registers
- AFA4000/E BACnet registers

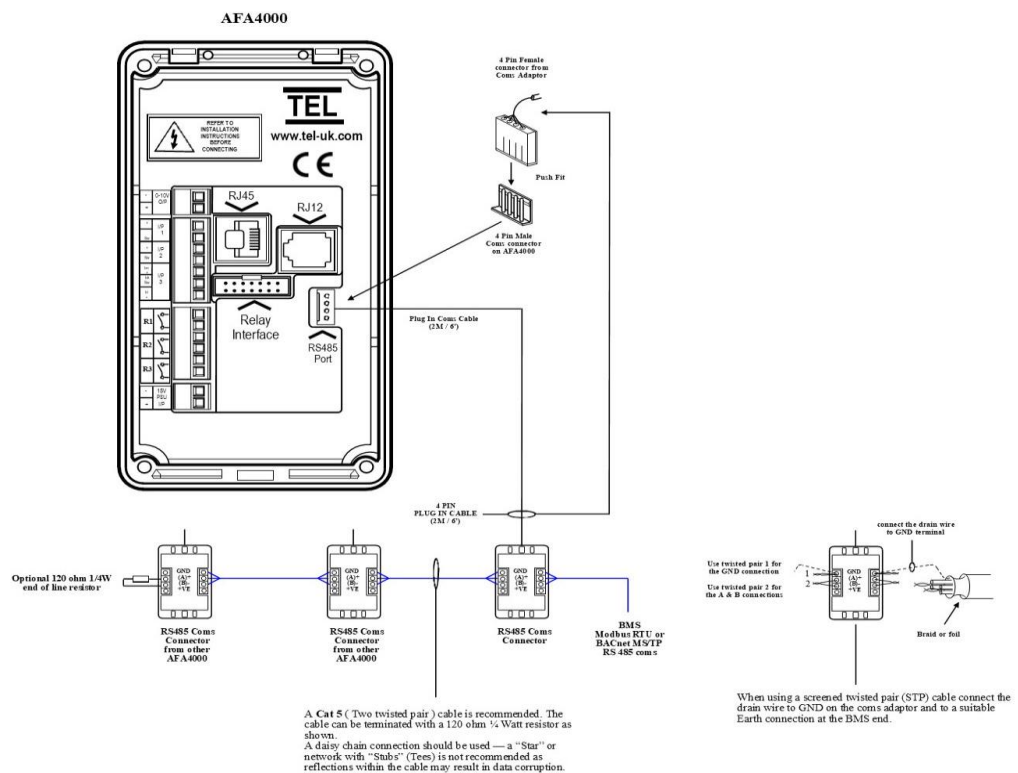

Figure 78 Typical connection diagram



## 10.2 Configuration settings

*Note:* When you change protocols, power cycle the AFA4000 to make sure that any changes you make take effect.

### 10.2.1 TEL protocols

The TEL protocols have no adjustable parameters.

*Note:* Use the ↑ / ↓ buttons to select items or enter values.

1. From the *Requires set up* screen, press **Mute**, or from the *Run Screen* press and hold the **Mute** button for 5 seconds until the *Main Menu* is displayed.
2. Select **Set Up Monitor > Configure**.
3. Enter the password (the factory default password is 0-0-0-0) and press **Mute** to continue.
4. Select **Protocol**, then press **Mute**.
5. Select **TEL, TELBUS or TEL 5000** and press **Mute**.
6. Select **Done** and press **Mute**.

### 10.2.2 MODBUS settings

To setup the AFA4000's MODBUS settings:

1. From the *Requires set up* screen, press **Mute**, or from the *Run Screen* press and hold the **Mute** button for 5 seconds until the *Main Menu* is displayed.
2. Select **Set Up Monitor > Configure**.
3. Enter the password (the factory default password is 0-0-0-0) and press **Mute** to continue.
4. Select **Protocol**, then press **Mute**.
5. Select **Modbus**, then press **Mute**.
6. Select **Modbus Settings** and press **Mute**.
7. The following parameters will be shown in a sub-menu:

	Parameter	Description	Range	Default
A	Slave ID	Set the slave ID	1-255	1
B	Baud rate	Set the network Baud Rate	• 1200 • 9600 • 38400 • 2400 • 14400 • 57600 • 4800 • 19200	9600
C	Parity	Set the required parity	Non/ Even/ Odd	None

8. Select **Slave ID**, then press **Mute**.



9. Enter the required ID and press **Mute**.
10. Select **Baud rate**, then press **Mute**.
11. Select the required rate and press **Mute**.
12. Select **Parity**, then press **Mute**.
13. Select the required parity and press **Mute**.
14. Select **Done**, then press **Mute**.

### 10.2.3 BACnet settings

To setup the AFA4000's BACnet settings:

1. From the *Requires set up* screen, press **Mute**, or from the *Run Screen* press and hold the **Mute** button for 5 seconds until the *Main Menu* is displayed.
2. Select **Set Up Monitor > Configure**.
3. Enter the password (the factory default password is 0-0-0-0) and press **Mute** to continue.
4. Select **Protocol**, then press **Mute**.
5. Select **BACnet**, then press **Mute**.
6. Select **BACnet Settings** and press **Mute**.
7. The following parameters will be shown in a sub-menu:

	Parameter	Description	Range	Default
A	Device Instance	Set the Slave ID for the unit	0000000 to 4194303	0000000
B	Station ID	Set the network ID	0-127	1
C	Baud rate	Set the required Baud Rate	<ul style="list-style-type: none"> <li style="margin-right: 10px;">• 1200</li> <li style="margin-right: 10px;">• 9600</li> <li style="margin-right: 10px;">• 38400</li> <li style="margin-right: 10px;">• 2400</li> <li style="margin-right: 10px;">• 14400</li> <li style="margin-right: 10px;">• 57600</li> <li style="margin-right: 10px;">• 4800</li> <li>• 19200</li> </ul>	38400
D	Parity	Set the required Parity	Non/ Even/ Odd	None
E	Max Masters	Set the max masters (max devices on the network)	0-127	1

8. Select **Device Instance**, then press **Mute**.
9. Enter the required instance and press **Mute**.
10. Select **Station ID**, then press **Mute**. Enter the required ID and press **Mute**.
11. Select **Baud rate**, then press **Mute**.
12. Select the required rate and press **Mute**.
13. Select **Parity**, then press **Mute**.



### 10.2.5.2 MODBUS protocol

If the device is not present on the network, check the following:

- Make sure the AFA4000 is either in Run mode or is displaying the Diagnostics screen. The comms are interrupted when the AFA4000 is in the pushbutton menus.
- Power cycle the AFA4000. This is required if the protocol has been changed.
- Make sure the network is MODBUS RTU.
- Use the Diagnostics Menu to check the comms settings are correct (see below):
  - Tx & Rx = 0 AFA4000 is not connected to the network (initial set up).
  - Tx & Rx >0 but fixed values AFA4000 has lost connection to the network.
  - Rx is counting but Tx is a fixed value AFA4000 is connected to the network but the Master (BMS) is offline or not polling the AFA4000.

## 10.3 Config Manager

The TEL software package, Config Manager is used for uploading and downloading parameter configuration files to the AFA4000. The Config Manager software is Windows based and requires a RS232/485 converter and TEL comms adaptor to communicate with the RS485 comms port on the AFA4000.

The software is free to download, and the comms adaptor is available to buy from TEL.

Most 3rd party RS232/485 converters will work with the AFA4000, the recommended converter has the part number: - EasySYNC ES-U-2101-M.

The part number is also available to buy directly from TEL.

Recommended minimum PC requirements: -

- Windows XP or later
- 2GHz processor
- 3.00 GB Ram
- 1MB free storage space

Config Manager uses the TEL protocol on the AFA4000.

For further information, see the Config Manager manual.

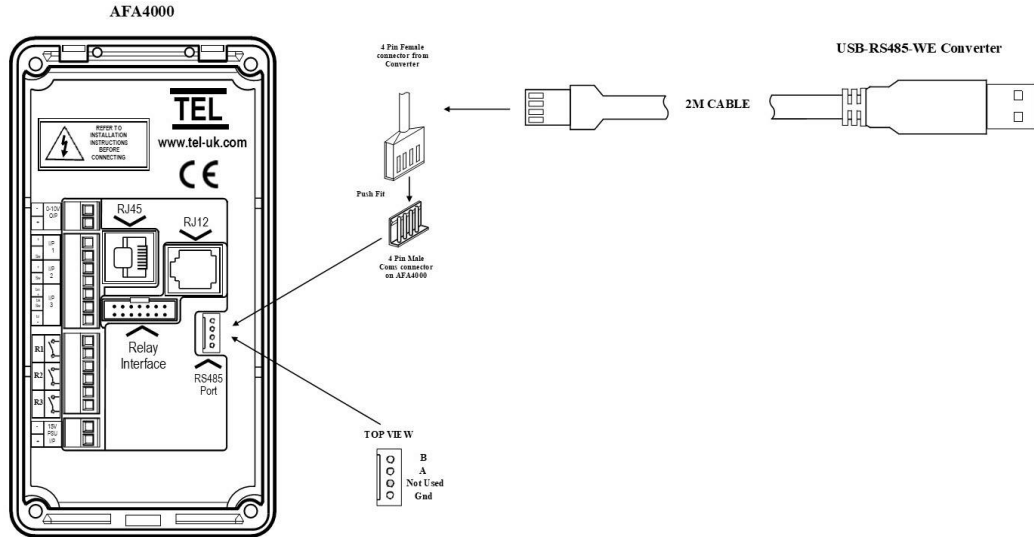

*Figure 79: Connection diagram with RS232/485 converter*

# 11. Operation: Airflow Monitor

## 11.1 Run screen

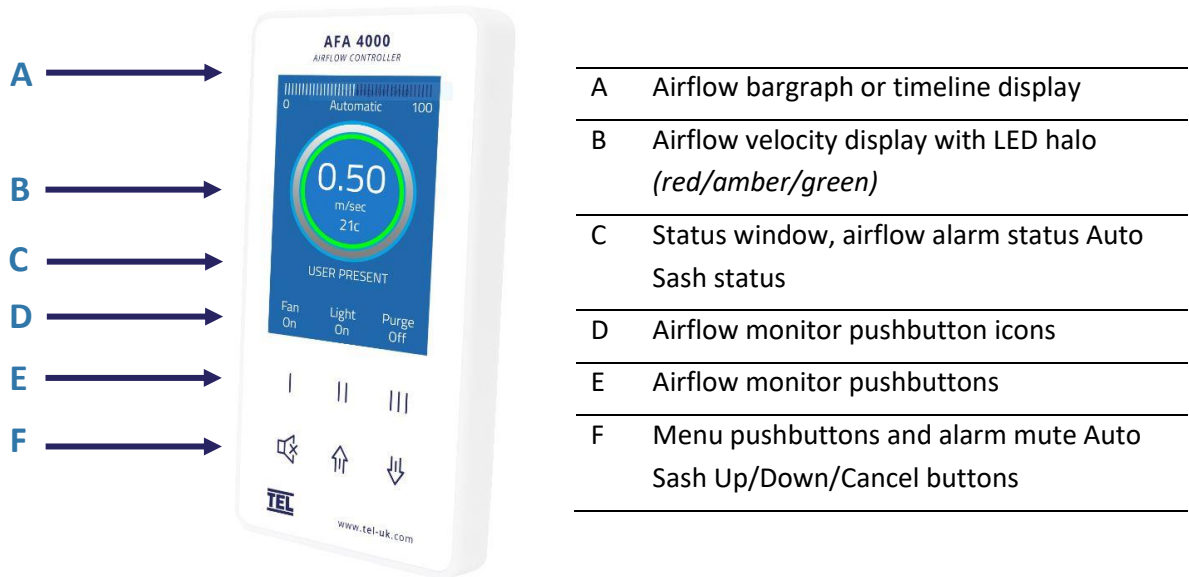

Figure 80: Operator display panel showing the Run screen

The Run screen displays when the AFA4000/E is switched on and shows the real-time status of the system.

The colour of the LED halo, text and status message is important:

Colour	Item	Meaning
GREEN	LED halo, text and status message	Airflow velocity is safe
AMBER	LED halo and text	Airflow velocity is marginal
RED	LED halo, text status message	Airflow velocity is low

## *12. Operation: Auto Sash Controller*

### *12.1 Control philosophy*

When all components are installed, setup and calibrated correctly, the Auto Sash Controller closes the sash after a pre-set delay, provided that the area in front of the fume hood is clear.

The following additional protocols also apply:

- When the user returns to the fume hood during the delay period, the control timer will stop and reset once the user leaves the fume hood again.
- When the user returns to a fume hood that is closing, the drive will stop when it senses the user.
- When an obstruction is detected under the sash, the Auto Sash Controller will not open or close the sash and will give a visual alarm to indicate a fault condition.
- When an obstruction is detected whilst the sash is closing, the sash drive will stop and give a visual indication to demonstrate a fault condition. To reset the fault alarm, press the reset button.
- When the sash starts to close a timer is initiated. When the sash does not close within the specified time, the sash drive will stop and will give a visual alarm to indicate a fault condition.
- When a user is present in front of the fume hood, the sash can be operated by hand.
- The sash can only be manually lifted to the normal position when the Auto stop is enabled.

### *12.2 Modes of operation*

The Auto Sash Controller has the following modes of operation:

- User Present
- User Not Detected
- Auto-Open (User Configurable)
- Building Management System (BMS) Inputs
- Sash Lock
- Auto Lock



### 12.2.1 User present

When the user is detected the sash can be moved in the following ways:

<b>Manually</b>	When the Tiptronic feature is enabled the sash can be manually moved, when it is kept moving for more than 1 second.  <i>Note: This is the minimum time for which the sash must travel to be operated manually. Movement for less than the specified time will lead to the sash auto-driving to the appropriate calibrated position.</i>
<b>Tiptronic</b>	When the sash is manually moved for less than 1 second the sash will auto-drive to its calibrated position.
<b>↑ / ↓ pushbuttons</b>	When pressed, the sash will auto drive to its calibrated position.
<b>Footswitch (open and close options) (optional)</b>	When operated, the sash will auto drive to its calibrated position.

### 12.2.2 User not detected

When the user is not detected, the sash will auto close to its calibrated position following a pre-set delay time unless:

- The sash beam is broken - object detected in the sash opening.
- The controller does not detect sash movement when the motor is driving.

### 12.2.3 Auto-open

Auto-Open is a user configurable process. When enabled, the sash automatically opens when the user returns following a pre-set delay.

- If the sash is auto-closed, the sash will automatically open back to the same position the sash was in before it automatically closed.
- If the sash is closed by any other method, for example manually, tiptronically, pushbutton and BMS, the sash will open automatically and return to its calibrated position.

The sash will not open automatically if:

- The sash beam is broken - object detected in the sash opening.
- The controller does not detect sash movement when the motor is driving.

### 12.2.3.1 AFA4000/E/AS only

When the Auto open feature is enabled in the menu and is switched on from the keypad, ‘\*’ displays in the left-hand corner of the Status Window, for example \* *User present*.

To enable Auto open, press and hold **Mute**. Then press and hold ↑ for 1 second or until the ‘\*’ symbol displays.

To disable Auto open, press and hold **Mute**. Then press and hold ↑ for 1 second or until the ‘\*’ symbol disappears.

### 12.2.4 Building Management System (BMS) inputs

The sash can be set to operate with the following BMS inputs:

Input	Description
<b>Open/Close</b>	Single start or end of day operation from BMS input. The sash will only drive when the user is not present and the sash beam is clear.
<b>EV (Emergency) Open/Close</b>	<i>Note: EV audible alarm tone will sound when the EV input is active.</i>  The sash will only drive if the user is not present and the sash beam is clear. In EV mode the sash can be manually moved when the user is detected. The sash will then auto drive closed/open again, when the EV input is still active and when the user is not detected.
<b>Fire Alarm Close</b>	<i>Note: An audible alarm tone will sound whilst the fire alarm input is active.</i>  The sash will only drive when the user is not present and the sash beam is clear. In Fire Alarm mode, the sash can be manually moved if the user is detected. The sash will then auto drive closed / open again, when the EV input is still active and when the user is not detected.

### 12.2.5 Sash lock

The sash can be set to *Lock, Auto Sash or Drive Inhibited*, when the sash is set to a calibrated position (for example fully open). An audible and visual alarm will activate following a pre-set alarm delay period, to remind the user to lower the sash.

This function is used when the sash needs to remain in the open position for a prolonged time, to allow loading or setting up of equipment inside the fume cupboard.

## 12.3 Operation and alarm indication

### 12.3.1 RUN mode

In *RUN mode*, the display will show the current status:

Current status	Description
<b>User present</b>	When user is detected. The sash drive is inhibited, tiptronic and manual drives are enabled.
<b>XX Seconds to close</b>	When user is not detected, the sash will close following the countdown delay time.
<b>Sash Closing</b>	Displayed when the sash is driving closed, for example tiptronic, auto-close, footswitch or pushbutton.
<b>Sash Closed</b>	When the user is not detected and the sash has closed. The keypad backlight is dimmed.
<b>XX Seconds to open</b>	When the user is detected, the sash opens, following the countdown delay time. Auto-open is enabled.
<b>Sash Opening</b>	Displayed when the sash is driving open, for example auto-open, tiptronic, footswitch or pushbutton.
<b>User Manual Move</b>	Displayed when the sash is manually opened or closed.
<b>Sash Inhibited</b>	Displayed when the tilt switch input is open. The drive is inhibited until the tilt switch is closed.
<b>Sash Disabled</b>	Displayed when the sash drive has been disabled in the menu settings.
<b>Sash Locked</b>	Displayed when the sash is at or above the calibrated lock position.
<b>Auto Stop</b>	Displayed when the sash is manually raised above the normal position when Auto stop is enabled.
<b>Base Moving</b>	Displayed when base movement is detected (DDA profile)
<b>New Base Height</b>	Displayed when the new base level is set (DDA profile)

## 12.3.2 Auto Sash settings

### 12.3.2.1 Stand alone

Auto-Open can be set to *Disabled*, *Enabled* or *Enabled if Auto-Closed*.

When the Auto-Open feature is enabled in the menu and is switched on from the keypad, '\*' displays in the left-hand corner of the screen. For example, \* *User present*.

To enable Auto-Open, press and hold the **Mute** button for 5 seconds or until the '\*' is displayed.

To disable Auto-Open, press and hold the **Mute** button for 5 seconds or until the '\*' disappears.

*Note: If set to Enabled if Auto-Closed, the sash will only Auto-Open if the sash has Auto-Closed.*

Closing the sash manually or by using the pushbuttons, will inhibit the Auto-Open when the user returns to the fume hood.

### 12.3.2.2 AFA4000/E/AS

The Auto Sash can be set to be *Disabled*, *Enabled* or *USR enabled (User enable / disable)*.

To User enable the Auto Sash, press and hold the **Mute** and ↑ buttons for 1 second.

To User disable the Auto Sash, press and hold the **Mute** and ↓ buttons for 1 second. *USR disabled* displays in the Status window.

*Note: Auto open can be set to disabled / enabled / enabled if auto closed. When set to enabled and when auto closed, the sash will only Auto open when the sash has auto closed.*

*Closing the sash manually or by using the pushbuttons will inhibit the auto open, when the user returns to the fume cupboard.*

## 12.3.3 Alarm indications

Auto Sash alarm indications are described in section 13.3.

# 13. Troubleshooting

## 13.1 Fault finding

### 13.1.1 AFA4000/E

Problem	Check for
<b>Screen blank</b>	<ul style="list-style-type: none"> <li>• Check the power supply is securely plugged into the monitor.</li> <li>• Check the power supply is securely plugged into the mains power socket.</li> <li>• Check that there is 15 Vdc power supply on the monitor terminals. If not, a wire could be broken or a cable sheath caught.</li> </ul>
<b>Sensor Error message</b>	<ul style="list-style-type: none"> <li>• Check the sensor cable is securely plugged into the sensor.</li> <li>• Check the sensor cable is securely plugged into the monitor.</li> <li>• Replace the sensor.</li> <li>• When the Sensor Error message is still displayed, replace the sensor cable.</li> <li>• When the Sensor Error message is still displayed, replace the monitor.</li> </ul>
<b>Audible alarm not working</b>	<ul style="list-style-type: none"> <li>• Check for screen messages. When <i>SETBACK</i> is displayed the monitor has been remotely muted.</li> <li>• Check to see if the alarm has been disabled in the <b>Cal config menu</b> (section 8.1.1.1).</li> </ul>
<b>Damper actuator not moving</b>	<ul style="list-style-type: none"> <li>• Check the Run screen to confirm that the displayed status is Automatic and not Manual.</li> <li>• Set the output to Manual and manually drive the actuator output. If the actuator does not move, check the wiring and make sure the actuator is not manually overridden.</li> </ul>
<b>RS485 Comms not connected</b>	<ul style="list-style-type: none"> <li>• See <b>Diagnostics menu</b>, Comms Data (section 13.2).</li> <li>• Check the correct Protocol, Slave ID, Baud Rate and Parity have been set.</li> <li>• Tx &amp; Rx = 0. The AFA4000 is not connected to the network.</li> </ul>

Problem	Check for
	<ul style="list-style-type: none"> <li>Tx &amp; Rx &gt;0 but fixed values. The AFA4000 has lost connection to the network.</li> <li>Rx is counting but Tx is a fixed value. The AFA4000 is connected to the network but the Master is offline or not polling the AFA4000.</li> </ul>

### 13.1.2 RS485 comms

Problem	Check for
<b>BACnet:</b> <b>Device not present on Network</b>	<ul style="list-style-type: none"> <li>Ensure the AFA4000/E is in Run mode or Diagnostics screen. The comms are interrupted when the AFA4000 is in the pushbutton menus.</li> <li>Power cycle the AFA4000. This is required when the protocol has been changed.</li> <li>Ensure Max Masters is set to the number of devices on the network. When the value set is larger than the actual number of devices the comms will be slowed and may cause time out issues.</li> <li>Ensure the network is BACnet MS/TP not BACnet IP - a separate router is required for IP.</li> <li>Check the comms settings are correct in the <b>Diagnostics menu</b> (section 13.2).</li> </ul>
<b>Modbus:</b> <b>Device not present on Network</b>	<ul style="list-style-type: none"> <li>Ensure the AFA4000/E is in Run mode or Diagnostics screen. The comms are interrupted when the AFA4000 is in the pushbutton menus.</li> <li>Power cycle the AFA4000. This is required when the protocol has been changed.</li> <li>Ensure the network is Modbus RTU.</li> <li>Check the comms settings are correct in the <b>Diagnostics menu</b> (section 13.2).</li> </ul>

### 13.1.3 Auto Sash

Problem	Check for
<b>Sash does not auto drive</b>	<ul style="list-style-type: none"> <li>• Ensure that there is mains power to the control unit and that all the connections are correct.</li> <li>• Ensure that the Sash 1 Settings Menu entry S1 Enabled is set to <i>Enabled</i>.</li> <li>• Ensure the Tilt Switch is connected or linked out, at the control box terminals.</li> </ul>
<b>Sash motor does not drive</b>	<ul style="list-style-type: none"> <li>• Check the motor and clutch are connected.</li> <li>• Check the sash position sensor or limit switch are connected.</li> </ul>
<b>Motor drives but clutch does not engage</b>	<ul style="list-style-type: none"> <li>• Ensure that the clutch is connected.</li> </ul>
<b>Sash does not drive to the correct positions</b>	Check the calibration is correct, re-calibrate the sash stop positions.
<b>Sash drive does not stop when sash is closed</b>	Ensure that the Sash Low switch is connected and operational.
<b>Sash drive is slow or fast</b>	Adjust the Sash 1 Settings Menu entry S1 Motor Speed, 0 - 100%.
<b>Auto sash status and menus not shown</b>	<ul style="list-style-type: none"> <li>• Check the RJ45 cable is connected at both ends.</li> <li>• Check the Auto Sash controller power supply is securely plugged into the mains power socket.</li> <li>• Power cycle the AFA4000 and check the version shown is AFA4000/E(S) S = Auto sash compatible.</li> </ul>
<b>Obstruction detected Alarm always shown</b>	<ul style="list-style-type: none"> <li>• Check the Light curtains or Under sash sensors have been calibrated.</li> <li>• Check the Light curtain or Under sash sensor Input polarity is correct (block the beam, if the error resets then the input polarity is wrong).</li> </ul>
<b>Sash Fault Alarm always shown</b>	The controller does not detect that the sash position sensor or limit switch is fitted, check the connections.
<b>Fault LED is illuminated</b>	Ensure that the area between the sash sensor transmitter and receiver is clear and that the sensors are aligned, power up again to reset.

## 13.2 Diagnostics menu

The AFA4000/E Diagnostics Menu shows the current input and output status, test the alarms and can be used to check the comms settings and operation, when the AFA4000 comms parameter settings have been configured.

Press the ↑ / ↓ buttons together from the Run screen to access the Diagnostics Menu. The menu contains the following Input and Output data:

*Note: Use the ↑ / ↓ buttons to scroll through the options, then press **Mute** to select the required parameter.*

Menu	Parameter/Action
<b>Alarm Test</b>	The audible alarm will sound and the screen displays the message <i>Testing Alarm</i> before returning to the Diagnostics menu.
<b>Comms Data</b>	<p>Displays the following:</p> <ul style="list-style-type: none"> <li>• Protocol (None / TEL / Modbus / BACnet)</li> <li>• Slave ID (for Modbus) or Device Instance (for BACnet)</li> <li>• Baud Rate</li> <li>• Parity</li> <li>• Tx – Number of Data Packets transmitted (increments when transmitting). The displayed value rolls over to zero when the maximum count is reached.</li> <li>• Rx – Number of Data Packets received (increments when receiving). The displayed value rolls over to zero when the maximum count is reached.</li> <li>• Tx &amp; Rx = 0. AFA4000 is not connected to the network (initial set up).</li> <li>• Tx &amp; Rx &gt;0, but fixed values. AFA4000 has lost connection to the network.</li> <li>• Rx is counting but Tx is a fixed value. AFA4000 is connected to the network but the Master (BMS) is offline or not polling the AFA4000.</li> </ul>



Menu	Parameter/Action
<b>I/O Status</b>	<p data-bbox="614 551 1085 577"><b>Input Data.</b> This displays the following:</p> <ul data-bbox="635 600 1342 734" style="list-style-type: none"> <li data-bbox="635 600 1342 627">• Input 1      On / Off, Analogue i/p voltage or Not Used</li> <li data-bbox="635 649 1342 676">• Input 2      On / Off, Analogue i/p voltage or Not Used</li> <li data-bbox="635 698 1342 725">• Input 3      On / Off, Analogue i/p voltage or Not Used</li> </ul> <p data-bbox="614 757 1426 824"><i>Note: On = input closed; Off = input open; analogue input voltage = 0 – 5 Vdc.</i></p> <p data-bbox="614 860 1107 887"><b>Output Data.</b> This displays the following:</p> <ul data-bbox="635 909 1110 1151" style="list-style-type: none"> <li data-bbox="635 909 930 936">• Output 1    On / Off</li> <li data-bbox="635 958 930 985">• Output 2    On / Off</li> <li data-bbox="635 1008 930 1034">• Output 3    On / Off</li> <li data-bbox="635 1057 1110 1084">• AOut 1      Analogue o/p 1 voltage</li> <li data-bbox="635 1106 1110 1133">• AOut 2      Analogue o/p 2 voltage</li> </ul> <p data-bbox="614 1164 1366 1232"><i>Note: On = output closed; Off = output open or not assigned; analogue output voltage = 0 – 10 Vdc.</i></p> <p data-bbox="614 1267 1101 1294"><b>Sensor Data.</b> This displays the following:</p> <ul data-bbox="635 1317 1401 1680" style="list-style-type: none"> <li data-bbox="635 1317 1401 1438">• Airflow            0 - 100%. Output of airflow sensor in % where 0% is maximum airflow and 100% is no airflow</li> <li data-bbox="635 1460 1401 1527">• Volume            Measured or calculated volume in l/sec or CFM (when enabled)</li> <li data-bbox="635 1550 1329 1617">• Sash position      Sash opening in mm or inches (when enabled)</li> <li data-bbox="635 1639 1366 1666">• Temperature      Temperature in °C or °F (when enabled)</li> </ul>
<b>Hours Counter</b>	Displays the hours that the fan has run since the last Hours Counter reset.
<b>Auto Sash Data</b> ( <i>only when Auto Sash is connected</i> )	<ul data-bbox="635 1800 1426 2007" style="list-style-type: none"> <li data-bbox="635 1800 1426 1868">• Position Status. The sash position is shown as % open when sash position sensor is used</li> <li data-bbox="635 1890 911 1917">• Alarm On / Off status</li> <li data-bbox="635 1939 930 1966">• Moving On / Off status</li> <li data-bbox="635 1989 983 2016">• Sash Closed On / Off status</li> </ul>

Menu	Parameter/Action
	<ul style="list-style-type: none"> <li>• Obstruction On / Off status</li> <li>• User On / Off status (User detected)</li> <li>• Sash open On / Off status</li> <li>• Sash Locked On / Off status</li> </ul>

### 13.3 *Auto sash alarm indications*

In an alarm condition, originating from within the fume hood, the current alarm displays in the status window:

Alarm message	Description
<b>Obstruction Detected</b>	<p>This is displayed when the sash beam is broken and when the sash starts to close.</p> <p>Remove the obstruction and press the <b>Mute</b> button to reset the alarm.</p>
<b>Sash Fault</b>	<p>This is displayed when the sash does not close or open when expected.</p> <p>Check the sash drive for faults and press <b>Mute</b> to reset the alarm.</p>
<b>Remove Sash Lock / Cancel to Reset</b>	<p>This is displayed when the sash is at or above the calibrated lock position for longer than the pre-set alarm time.</p> <p>Press <b>Mute</b> or lower the sash to reset the alarm.</p>

When a BMS input is in an active condition, the current alarm displays in the status window:

Alarm message	Description
<b>Fire Alarm</b>	This is displayed along with the normal text, for example <i>Fire Alarm</i> or <i>User present</i> , when the fire alarm input is activated. The sash will drive closed when the user is not detected and the sash is clear. The sash can be operated manually when the user is detected (auto open, tiptronic & pushbuttons are disabled).
<b>BMS open</b>	This is displayed along with the normal text when the user is not detected and when the BMS Open input is activated. The sash will drive open when the user is not present and the sash is clear. The sash can be operated normally when the user is detected (auto open, tiptronic & pushbuttons are active).
<b>BMS close</b>	This is displayed when the BMS Close input is activated, the sash will drive closed when the user is not present and the sash is clear. The sash can be operated normally when the user is detected (auto open, tiptronic & pushbuttons are active).
<b>Emergency (up)</b>	This is displayed along with the normal text when the user is not detected and when the EV Open input is activated. The sash will drive open when the user is not present and the sash is clear. The sash can be operated manually when the user is detected (auto open, tiptronic & pushbuttons are disabled).
<b>Emergency (dn)</b>	This is displayed along with the normal text when the user is not detected and when the EV Close input is activated. The sash will drive closed when the user is not present and the sash is clear. The sash can be operated manually when the user is detected (auto open, tiptronic & pushbuttons are disabled).
<b>Sash Opening</b>	This is displayed when the Sash Open Footswitch has been operated whilst the operator is present.
<b>Sash Closing</b>	This is displayed when the Sash Close Footswitch has been operated whilst the operator is present.

## 14. Cleaning and maintenance

### 14.1 Cleaning

The Auto Sash Controller and AFA4000/E are generally maintenance free.

All parts fitted within the laboratory space may need occasional cleaning depending on the environmental conditions and usage. Include the following:

Part	Method	Notes
<b>Keypad</b>	Use a dry cloth, optical lens or screen wipe to remove dust, dirt, grease or finger marks.	Do not remove the keypad whilst the unit is powered up. Isolate the power if the keypad is removed for cleaning.
<b>Personnel Sensor</b>	Use a dry cloth, optical lens or screen wipe to remove dust, dirt, grease or finger marks.	Do not adjust the sensor position whilst cleaning. If the sensor angle is adjusted the user detection may be compromised.
<b>Light Curtains</b>	Use a dry cloth, optical lens or screen wipe to remove dust, dirt, grease or finger marks.	The Light Curtain is calibrated to detect glass objects. Make sure the light curtain is kept free from obstructions and kept clean.
<b>Under Sash sensor</b>	Use a dry cloth, optical lens or screen wipe to remove dust, dirt, grease or finger marks.	Do not adjust the sensor position whilst cleaning. If the sensor angle is adjusted the sensor beam will be compromised.

## 14.2 Contamination

When any part of the Auto Sash Control system is contaminated it must be either removed and decontaminated or disposed of and replaced with a new part.

The local in-house Risk assessment, removal and disposal procedures (SOP) and COSHH requirements must be observed whilst de-contaminating or disposing of the contaminated part and should only be carried out by trained and competent parties.

Isolate the power to the controller before removing or replacing any contaminated parts to avoid the risk of electric shock.

## 14.3 Maintenance

### 14.3.1 Faulty / replacement parts

If a faulty part has been identified (section 13.1), the Auto Sash Control system should be isolated and marked as *Faulty – do not use /Out of service* until a replacement part has been fitted. The fume cupboard can be operated manually during this period.

No special tools or parts are required for maintenance.

### 14.3.2 Validation

Once a replacement part has been fitted the Auto Sash Control system operation should be fully tested to ensure safe operation.

A new tested label should be fitted or a new date should be applied to an existing label to show that the system has been repaired and tested and is safe to use.

## 15. Technical specifications

### 15.1 AFA4000/E Airflow Monitor

#### 15.1.1 Physical

Specification	AFA4000
Dimensions (device)	148 mm (H) x 80 mm (W) x 25.9 mm (max) (D)
Dimensions (mounting bracket)	143.8 mm (H) x 75.4 mm (W)
Mounting	Semi flush
Connections	Flying leads with plug in connections
Airflow sensor	Remote SM7 / ILS (In-line Sensor)
Pushbuttons	Three Configurable pushbuttons
Display	Digital velocity display m/sec Graphical display: <ul style="list-style-type: none"> <li>• Green: Safe</li> <li>• Amber: Caution</li> <li>• Red: Alarm</li> </ul>
Com port	RS485 com port Modbus RTU and BACnet
Alarm indication	Red graphic with Audible alarm

#### 15.1.2 Operational information

Specification	AFA4000
Alarm range	0.20 - 2.00 m/s remote SM7 or ILS Airflow sensor
Control range	Face Velocity control 0.20 - 2.00 m/sec
Control resolution	0.01 m/sec
Control response	< 2 seconds

Specification	AFA4000
Control output 1	0 - 10 / 2 - 10 Vdc control output for damper, valve or inverter drive
Control output 2	0 - 10 / 2 - 10 Vdc control output for bleed or supply air damper/inverter or 0 - 10 Vdc volumetric output
Field set up	2-point velocity calibration with on screen instructions
Accuracy	Face velocity $\pm$ 5%

### 15.1.3 I/O

Specification	AFA4000
Digital output	3 configurable outputs
Digital input	3 configurable inputs
Night setback	Digital input activation
Sash high	Digital input activation via proximity sensor or micro switch

### 15.1.4 Temperatures

Specification	AFA4000
Monitor operating range	+13 to +30°C
Airflow sensor operating temperature	+15 to +30°C
Airflow sensor working temperature	Ambient to +30°C
Storage temperature	-30 to +65°C

### 15.1.5 Regulatory

Specification	AFA4000
Agency listings	CE RoHS
Hazardous area (remote airflow sensor)	Gas group IIC Temp Class T6 with ATEX certified I.S. Zener Barriers

## 15.2 Auto Sash Controller

### 15.2.1 General

	Auto Sash Controller	Options and features
<b>Power Supply</b>	1005 -240 Vac; 50/60 Hz; 3 A	<ul style="list-style-type: none"> <li>• 2 m power lead with plug-in connector</li> <li>• 0.75 mm<sup>2</sup>, 300 V, 6 A rated cable</li> </ul>
<b>Keypad</b>	16*2 Backlit LCD display with pushbuttons	<ul style="list-style-type: none"> <li>• UK single gang socket (85 mm x 85 mm) version</li> <li>• US single gang socket (3" x 2") version</li> </ul>
<b>Drive Motor Assembly</b>	PWM output DC motor and clutch	<ul style="list-style-type: none"> <li>• Chain and sprocket shaft drive</li> <li>• Sash wire pulley drive</li> <li>• Rack and pinion sash direct sash drive</li> </ul>
<b>Personnel Sensor</b>	PIR with background re-learn function	
<b>Sash Position Sensor</b>	Steel wire sprung potentiometer	<ul style="list-style-type: none"> <li>• 1 m length for bench type F/Cs</li> <li>• 3 m length for walk-in type F/Cs</li> </ul>
<b>Sash Sensor</b>	PIR sensor with glass detection	<ul style="list-style-type: none"> <li>• Light Curtain (retro-fit and new build types)</li> <li>• Under the sash retro-reflective (single sensor)</li> </ul>
<b>Tilt Switch</b>	Inhibits controller when switch is open	Fitted to the access panel of the fume hood
<b>Field Set up</b>	Menu calibration and setup with password protection	Menu adjustment of motor speed / time delays etc
<b>BMS Inputs</b>	4 programmable volt-free inputs	<ul style="list-style-type: none"> <li>• Open sash</li> <li>• Close sash</li> <li>• Fire Alarm (close sash)</li> <li>• Emergency open / close sash</li> </ul>



	Auto Sash Controller	Options and features
<b>BMS Outputs</b>	Programmable volt-free (sash position) outputs: Voltage: <ul style="list-style-type: none"> <li>• 0 – 10 V</li> <li>• 1 – 10 V</li> <li>• 0 – 5 V</li> <li>• 1 – 5 V</li> </ul> Current: <ul style="list-style-type: none"> <li>• 0 – 20 mA</li> <li>• 4 – 20 mA</li> </ul>	<ul style="list-style-type: none"> <li>• Always Open / Closed</li> <li>• Open / Close on sash fault alarm</li> <li>• Open / Close on user detected</li> <li>• Open / Close on obstruction detected</li> <li>• Open / Close on sash open / closed</li> <li>• Remote audible alarm</li> </ul>
<b>Control Functions</b>	Sash operation	<ul style="list-style-type: none"> <li>• Manual sash operation (where user detected) Tiptronic 'touch sensitive' open/close</li> <li>• Auto-Close (unoccupied condition)</li> <li>• Auto-Open (pushbutton enable feature)</li> <li>• Keypad Pushbutton open/close</li> <li>• Footswitch open/close (optional)</li> <li>• BMS input open / close</li> </ul>
<b>Alarms</b>	Audible/visible indication	<ul style="list-style-type: none"> <li>• Obstruction detected</li> <li>• Sash fault</li> </ul>
<b>Status Indication</b>	Keypad LCD display	Sash status (user present / open / closing / closed etc)
<b>Connections</b>	Flying leads with plug-in connections	(All cable lengths can be specified)
<b>Agency Listing</b>	CE RoHS	
<b>Mains Power Protection</b>	On-board fuse (F1)	3.15 A, 250 V rated

### 15.2.2 Environmental conditions

	Rating	Notes
<b>Pollution Degree</b>	Pollution degree 2	Laboratory Areas
<b>Over-Voltage Category</b>	300 V Cat II	
<b>Operating Temperature Range</b>	-20 to 60 °C	
<b>Operating Humidity Range</b>	20 - 90% RH non-condensing	
<b>Storage Temperature Range</b>	-20 to 80 °C	

### 15.2.3 Controller connections

Connector	Terminal Connection	Ratings & Specification
<b>Power Supply CN15</b>	<ul style="list-style-type: none"> <li>2 m power lead with flying lead with 3 Way plug in terminal block</li> <li>0.75mm<sup>2</sup>, 300 V, 6 A Rated Cable</li> </ul>	<ul style="list-style-type: none"> <li>100-240 Vac; 50/60 Hz; 3A (Fused 3.15 A)</li> </ul>
<b>Keypad CN4</b>	<ul style="list-style-type: none"> <li>Backlit LCD display with pushbuttons</li> <li>RJ45 Cable 2 m</li> </ul>	<ul style="list-style-type: none"> <li>Max 24 Vdc 100 mA (PTC Fused 200 mA)</li> </ul>
<b>Drive Motor Assembly CN7</b>	<ul style="list-style-type: none"> <li>2 m flying lead with 4-way plug-in terminal block</li> </ul>	<ul style="list-style-type: none"> <li>Motor 0-24 Vdc PWM Output Clutch 24 Vdc</li> <li>Max total power 135W (5.6A)</li> </ul>
<b>Personnel Sensor CN6</b>	<ul style="list-style-type: none"> <li>2 m flying lead with 4-way plug-in terminal block</li> </ul>	<ul style="list-style-type: none"> <li>Max 24 Vdc 100 mA (PTC Fused 200 mA)</li> </ul>
<b>Sash Position Sensor CN5</b>	<ul style="list-style-type: none"> <li>2 m flying lead with 3-way plug-in terminal block</li> </ul>	<ul style="list-style-type: none"> <li>Bottom Switch: 24 V (PTC Fused 200 mA)</li> <li>Sash Pos Sensor: 3.3 Vdc 43 mA Max</li> </ul>
<b>Sash Sensor CN3</b>	<ul style="list-style-type: none"> <li>PIR sensor with Glass Detection Light Curtain or Under Sash Sensor with 3 m flying lead</li> </ul>	<ul style="list-style-type: none"> <li>Max 24 Vdc 100 mA (PTC Fused 200 mA)</li> </ul>

Connector	Terminal Connection	Ratings & Specification
<b>Tilt Switch CN2</b>	<ul style="list-style-type: none"> <li>2-way plug in terminal block</li> </ul>	<ul style="list-style-type: none"> <li>Max 24 Vdc 100 mA (PTC Fused 200 mA)</li> </ul>
<b>BMS Output Relays CN11,12,13,14</b>	<ul style="list-style-type: none"> <li>4 programmable volt-free outputs</li> <li>Change-over relays R1 -R4 3-way plug-in terminal blocks</li> </ul>	<ul style="list-style-type: none"> <li>Max 30 Vac/dc 1 A</li> </ul>
<b>Analogue Outputs CN9</b>	<ul style="list-style-type: none"> <li>6-way plug-in terminal block</li> <li>0-10 Vdc over Sash Height (2-way) (Programable 0-10, 1-10,0-5,1-5V)</li> <li>4-20mA over Sash Height (2 Way) (Programable 0-20 or 4-20 mA)</li> <li>External Sounder (2-way)</li> </ul>	<ul style="list-style-type: none"> <li>0-10 V Max 10 V (Current limited)</li> <li>4-20 mA Max 24 V</li> <li>Max 24 Vdc 100 mA (PTC Fused 200 mA)</li> </ul>
<b>BMS Digital Inputs CN10</b>	<ul style="list-style-type: none"> <li>4 programmable digital inputs</li> <li>8-way plug-in terminal block</li> </ul>	<ul style="list-style-type: none"> <li>Max 24 Vdc 100 mA per input</li> <li>Input impedance 100 kΩ</li> </ul>
<b>RS485 Comms (Optional)</b>	<ul style="list-style-type: none"> <li>Plug-in expansion module</li> <li>8-way plug in terminal block</li> </ul>	<ul style="list-style-type: none"> <li>Isolated RS485 output</li> </ul>

#### 15.2.4 Supply and field wiring requirements

<b>Mains Supply</b>	UK	3-pin single-gang socket or fused spur 3 A rated for 3-pin plug
	USA	2-pin single-gang socket or fused spur 3 A rated for 2-pin plug
	EURO	2-pin single-gang socket or fused spur 3 A rated for 2-pin plug

*Note: The controller should be positioned so that the mains connection can easily be isolated. Ensure that the mains connector can be accessed for removal.*

#### 15.2.5 Auxiliary equipment interconnections

##### 15.2.5.1 TEL supplied equipment

All TEL supplied equipment is provided with plug-in terminal connections.

1. Isolate the mains supply to the controller **before** connecting any equipment.
2. Follow the installation instructions in the relevant sections of this manual.

3. Where possible test the mechanical operation of the equipment before the mains power is switched on to the controller. Test that the sash position sensor draw wire is free and is not catching.

#### *15.2.5.2 3rd party equipment*

All 3rd party equipment must be within the electrical specification (page 200) and the connection diagram on page 96.

All 3rd party equipment performance must comply with the requirements of the Auto Sash controller. Parameter re-configuration may be required, when the equipment does not meet the required performance characteristics for the factory settings.

1. Isolate the mains supply to the controller **before** connecting any equipment.
2. Follow the installation instructions in the relevant sections of this manual.
3. Where possible test the mechanical operation of the equipment before the mains power is switched on to the controller. Test that the motor assembly is free and the sash moves correctly by hand. Test that the sash position sensor draw wire is free and not catching.



## 16. Warranty

Seller warrants that this product, under normal use and service as described in the operator's manual shall be free from defects in workmanship and material for a period of twelve (12) months, or the length of time specified in the operator's manual, from the date of shipment to the customer. This limited warranty is subject to the following exclusion:

1. Batteries and certain other components when indicated in specifications are warranted for a period of 90 days from the date of shipment to the customer.
2. With respect to any repair services rendered, Seller warrants that the parts repaired or replaced will be free from defects in workmanship and material, under normal use, for a period of 90 days from the date of shipment to the customer
3. Seller does not provide any warranty on finished goods manufactured by others. Only the original manufacturer's warranty applies
4. Unless specifically authorized in a separate writing by Seller, Seller makes no warranty with respect to, and shall have no liability in connection with, any goods which are incorporated into other products or equipment by the Buyer. All goods returned under warranty shall be at the Buyer's risk of loss, Seller's factory prepaid, and will be returned at Seller's risk of loss, Buyer's factory prepaid.

The foregoing is IN LIEU OF all other warranties and is subject to the conditions and LIMITATIONS stated herein. NO OTHER EXPRESS OR IMPLIED WARRANTY OF FITNESS FOR PARTICULAR PURPOSE OR MERCHANTABILITY IS MADE.

THE EXCLUSIVE REMEDY OF THE USER OR PURCHASER, AND THE LIMIT OF LIABILITY OF SELLER FOR ANY AND ALL LOSSES, INJURIES, OR DAMAGES IN CONNECTION WITH THIS PRODUCT ( INCLUDING CLAIMS BASED ON CONTRACT NEGLIGENCE, STRICT LIABILITY, OTHER TORT, OR OTHERWISE ) SHALL BE THE RETURN OF THE PRODUCT TO THE FACTORY OR DESIGNATED LOCATION AND THE REFUND OF THE PURCHASE PRICE, OR, AT THE OPTION OF THE SELLER, THE REPAIR OR REPLACEMENT OF THE PRODUCT. IN NO EVENT SHALL SELLER BE LIABLE FOR ANY SPECIAL, INCIDENTAL OR CONSEQUENTIAL DAMAGES. SELLER SHALL NOT BE RESPONSIBLE FOR INSTALLATION, DISMANTLING, REASSEMBLY OR REINSTALLATION COSTS OR CHARGES. NO ACTION, REGARDLESS OF FORM, MAY BE BROUGHT AGAINST THE SELLER MORE THAN ONE YEAR AFTER THE CAUSE OF ACTION HAS ACCRUED.

The purchaser and all users are deemed to have accepted the terms of this LIMITATION OF WARRANTY AND LIABILITY, which contains the complete and exclusive limited warranty of Seller. This LIMITATION OF WARRANTY AND LIABILITY may not be amended or modified nor may any of its terms be waived except by a writing signed by an authorized representative of the Seller.

## 17. Index

AFA4000/E .....	97	auto sash controller	
calibration.....	97	calibration.....	100
messages.....	98	cleaning.....	187
notes.....	98	contamination.....	188
airflow functions.....	22	installation .....	64
airflow monitor		control box wiring diagram .....	95
audible alarm sounder.....	16	control unit .....	64
auxiliary components .....	35	mounting.....	64
components.....	33	wiring .....	65
damper control.....	34	motor drive unit.....	67
inverter control.....	33	chain and sprocket .....	71
display.....	12	chain and sprocket counterweight drive .....	72
features .....	12	rack and pinion.....	67
display panel navigation.....	18	wire and pulley drive.....	73
autosash configuration menu .....	19	personnel sensor.....	88
main menu .....	18	adjust beam depth .....	91
monitor set up menu .....	18	adjust beam width.....	90
external connections.....	20	dip switch settings.....	93
communications .....	21	sash light curtain .....	73
inputs.....	20	aligning transmitter and receiver .....	76
optional inputs .....	21	control box.....	74
outputs .....	20	receiver.....	75
power supply .....	21	transmitter .....	75
functions.....	22	sash low switch.....	84
airflow functions.....	22	micro switch .....	84
audible alarm mute .....	23	proximity switch .....	85
input functions.....	28	sash position sensor.....	86
pushbutton functions .....	23	tilt switch .....	83
installation.....	47, 49	under sash sensor .....	81
AFA4000/E.....	49	maintenance .....	188
connections .....	54	faulty / replacement parts.....	188
dimensions .....	60	validation.....	188
location.....	47	overview.....	36
SM7 airflow sensor.....	52	control system components.....	40
start up.....	62, 96	auto sash control unit.....	41
AFA4000/E .....	62	foot switch.....	46
AFA4000/E/AS.....	62	personnel sensor .....	42
LED indicators .....	16	sash drive unit .....	46
overview .....	11	sash light curtain .....	42
pushbuttons.....	16	sash low switch.....	44
alarm indications .....	185	sash position sensor .....	44
alarms.....	14	tilt switch.....	45
audible alarm.....	16		

under sash sensor.....	43	damper control .....	34
features .....	36	inverter control .....	33
options.....	37	configuration.....	109
sash low micro switch.....	38	AFA4000/E configuration menus .....	110
sash low proximity switch .....	39	BACnet settings menu.....	116
Tiptronic open/close control.....	37	cal config menu .....	114
auto sash controller (stand-alone)		hours counter menu.....	115
calibration.....	103	MODBUS settings menu .....	116
auto sash keyboard .....	103	monitor config menu .....	111
personnel sensor .....	108	AFA4000/E/AS configuration menus ...	125
safety light curtain .....	105	auto sash engineering menu .....	132
sash lock function .....	105	auto sash setup menu.....	125
sash low switch.....	108	auto sash controller system menus .....	149
sash position sensor .....	108	accessing system menus.....	151
start up .....	103	bms input settings menu .....	154
tilt switch.....	108	bms output settings menu.....	156
auxiliary features and connections .....	157	keypad tones.....	152
close sash alarm .....	162	navigating system menus .....	152
dual set point operation .....	157	sash 1 settings menu .....	152
fail safe damper operation .....	166	control settings .....	117
temperature sensor .....	159	Econ configure menu .....	118
calibration.....	97	control setup guide .....	124
AFA4000/E .....	97	dual output econ output 2 .....	137
messages.....	98	contents .....	2
notes.....	98	control setup guide .....	124
auto sash controller.....	100	controls .....	16
auto sash controller (stand-alone) .....	103	diagnostics menu .....	183
auto sash keyboard .....	103	display features.....	12
personnel sensor .....	108	display panel .....	12
safety light curtain .....	105	dual output econ output 2 .....	137
sash lock function .....	105	bleed damper.....	137
sash low switch.....	108	pressure cell .....	144
sash position sensor .....	108	sash position sensor .....	146
start up .....	103	volume .....	146
tilt switch.....	108	volume pressure.....	140
sash lock function .....	102	dual set point operation.....	157
Tiptronic auto sash controller		econ configure menu.....	118
notes.....	101	electrical protection .....	9
cleaning and maintenance.....	187	electrical safety .....	8
auto sash controller		EMC compliance.....	10
cleaning .....	187	events.....	14
contamination .....	188	fail safe damper operation.....	166
maintenance.....	188	fault finding.....	180
close sash alarm.....	162	AFA4000/E .....	180
com port.....	21	auto sash.....	182
communications.....	21	RS485 comms.....	181
components .....	33	features .....	5



<i>index</i> .....	196	<i>user present</i> .....	175
<i>indicators</i> .....	16	<i>operation and alarm indication</i> .....	178
<i>input functions</i> .....	28	<i>alarm indications</i> .....	179
<i>analogue</i> .....	28	<i>auto sash settings</i> .....	178
<i>digital</i> .....	29	<i>RUN mode</i> .....	178
<i>inputs</i> .....	20	<i>outputs</i> .....	20
<i>auto sash keypad</i> .....	22	<i>analogue</i> .....	21
<i>mains fail battery unit</i> .....	22	<i>relays</i> .....	20
<i>optional</i> .....	21	<i>overview</i>	
<i>PIR occupancy sensor</i> .....	21	<i>airflow monitor</i> .....	11
<i>temperature sensor</i> .....	21	<i>alarms</i> .....	14
<i>installation</i>		<i>components</i> .....	33
<i>airflow monitor</i> .....	47, 49	<i>controls</i> .....	16
<i>connections</i> .....	54	<i>display</i> .....	12
<i>dimensions</i> .....	60	<i>display features</i> .....	12
<i>location</i> .....	47	<i>display panel navigation</i> .....	18
<i>start up</i> .....	62, 96	<i>events</i> .....	14
<i>auto sash controller</i> .....	64	<i>external connections</i> .....	20
<i>control box wiring diagram</i> .....	95	<i>functions</i> .....	22
<i>control unit</i> .....	64	<i>indicators</i> .....	16
<i>motor drive unit</i> .....	67	<i>introduction</i> .....	11
<i>personnel sensor</i> .....	88	<i>auto sash controller</i> .....	36
<i>sash light curtain</i> .....	73	<i>control system components</i> .....	40
<i>sash low switch</i> .....	84	<i>features</i> .....	36
<i>sash position sensor</i> .....	86	<i>options</i> .....	37
<i>tilt switch</i> .....	83	<i>power supply</i> .....	21
<i>under sash sensor</i> .....	81	<i>pushbutton functions</i> .....	23
<i>introduction</i> .....	5	<i>pushbuttons</i> .....	16
<i>features</i> .....	5	<i>RS485 communications output</i> .....	168
<i>LED Halo indicator</i> .....	16	<i>config manager</i> .....	172
<i>mute</i> .....	23	<i>configuration settings</i> .....	169
<i>navigation</i> .....	18	<i>connections</i> .....	168
<i>auto sash configuration menu</i> .....	19	<i>overview</i> .....	168
<i>main menu</i> .....	18	<i>safety</i> .....	6
<i>monitor set up menu</i> .....	18	<i>electrical</i> .....	8
<i>operating conditions</i> .....	7	<i>electrical protection</i> .....	9
<i>environmental conditions</i> .....	7	<i>EMC compliance</i> .....	10
<i>general operation</i> .....	7	<i>operating conditions</i> .....	7
<i>operation</i>		<i>environmental conditions</i> .....	7
<i>airflow monitor</i> .....	174	<i>general operation</i> .....	7
<i>auto sash controller</i> .....	175	<i>precautions</i> .....	6
<i>control philosophy</i> .....	175	<i>safety practices</i> .....	6
<i>modes of operation</i> .....	175	<i>warnings</i> .....	6
<i>auto open</i> .....	176	<i>labels</i> .....	6
<i>bms inputs</i> .....	177	<i>notices</i> .....	6
<i>sash lock</i> .....	177	<i>sash lock function</i>	
<i>user not detected</i> .....	176	<i>calibration</i> .....	102



<i>SM7 airflow sensor</i> .....	48	<i>temperature sensor</i> .....	159
<i>  installation notes</i> .....	48	<i>Tiptronic Auto Sash Controller</i>	
<i>  mounting</i> .....	52	<i>calibration</i>	
<i>technical specifications</i> .....	189	<i>notes</i> .....	101
<i>AFA4000/E</i> .....	189	<i>troubleshooting</i> .....	180
<i>  I/O</i> .....	190	<i>alarm indications</i> .....	185
<i>  operational</i> .....	189	<i>diagnostics menu</i> .....	183
<i>  physical</i> .....	189	<i>fault finding</i> .....	180
<i>  regulatory</i> .....	190	<i>AFA4000/E</i> .....	180
<i>  temperatures</i> .....	190	<i>auto sash</i> .....	182
<i>auto sash controller</i> .....	191	<i>RS485 comms</i> .....	181
<i>  auxiliary equipment interconnections</i>	194	<i>warnings</i> .....	6
<i>  connections</i> .....	193	<i>labels</i> .....	6
<i>  environmental</i> .....	193	<i>notices</i> .....	6
<i>  general</i> .....	191	<i>warranty</i> .....	196
<i>  wiring requirements</i> .....	194		



**Temperature Electronics Ltd.**

Unit 2  
Wren Nest Road  
Glossop  
SK13 8HB  
United Kingdom

**T: +44 (0) 1457 865 635**

**E: [sales@tel-uk.com](mailto:sales@tel-uk.com)**

***[www.tel-uk.com](http://www.tel-uk.com)***